



Spartanburg Water

Cross Connection Control Manual

Revised 9/25/2018

Spartanburg Water Cross Connection Control Manual

Cross Connection Control Program Manual Index

SECTION 1 - PURPOSE	page 3
SECTION 2 - AUTHORITY	page 3
SECTION 3 - REGULATION	page 3
SECTION 4 - DEFINITIONS	page 3
SECTION 5 – RESPONSIBILITIES	page 6
SECTION 6 - REQUIREMENTS	page 7
SECTION 7 - DEGREE OF HAZARD	page 8
SECTION 8 - INSTALLATION	page 8
New Connections 8.1	
Existing Service Connections 8.2	
Right of Entry 8.3	
Wells 8.4	
SECTION 9 - INSTALLATION REQUIREMENTS	page 9
Hazard Applications 9.1	
Location 9.2	
Rp and DCVA Installation Requirements 9.3	
Additional Requirements for Rps 9.4	
Fire Suppression/Fire Sprinkler Systems 9.5	
Removal of Assembly 9.6	
SECTION 10 - TESTING REQUIREMENTS	page 11
Residential Lawn Irrigation Systems 10.1	
Testing Assemblies 10.2	
Test Failures 10.3	
Testing Non-Compliance 10.4	
SECTION 11 - NON-COMPLIANCE/ENFORCEMENT	page 13
Enforcement Authority 11.1	
Enforcement Procedure 11.2	
Termination of water service/Reconnect fees 11.3	
Legal Action 11.4	
SECTION 12 – APPEALS	page 16
SECTION 13- THERMAL EXPANSION	page 18
ATTACHMENTS	
Forms	
Letters	
Lists	
Specifications	
Flow Charts	

Spartanburg Water Cross Connection Control Manual

SECTION 1 - PURPOSE

1. To protect the public potable water supply served by Spartanburg Water from the backflow or back-siphoning of pollutants or contaminants that may be present within its customer's water distribution system.
2. To eliminate or control existing cross connections between its customers' potable and non-potable water systems.
3. To prevent the contamination or pollution of Spartanburg Waters potable water system by establishing an ongoing maintenance program for cross connections.

SECTION 2 - AUTHORITY

The Federal Safe Drinking Water Act of 1974 and South Carolina State Primary Drinking Water Regulations promulgated pursuant to Section 44-55-30 through 44-55-60 of the 1976 South Carolina Code of Laws, Regulation 61-58.7(F) requires that the water purveyor has the primary responsibility for preventing water from unapproved sources, or any other substances, from entering the public potable water system.

SECTION 3 - REGULATION

State Regulation 61-58.7(F) requires that all public water systems initiate and maintain a viable cross connection control program. The program shall consist of:

1. Locating and eliminating unprotected cross connections
2. Maintaining records pertaining to the location of existing backflow prevention assemblies, type, and size of each assembly and test results (when applicable).

No person shall install, permit to be installed or maintain any cross connection between a public water system and any other non-public water system, sewer, or a line from any container or liquids or other substances, unless an approved backflow prevention device or assembly is installed between the public water system and the source of contamination.

SECTION 4 - DEFINITIONS

Approved means accepted by Spartanburg Water as meeting the applicable specification stated or cited in this manual or as suitable for the proposed use.

Auxiliary Water Supply means any water supply on or available to the premises other than the Spartanburg Water approved water supply. Auxiliary water supplies may include water from other water purveyor's public potable water system or any natural source such as a well, spring, river, stream, etc., or used waters, or industrial fluids. They may be polluted or contaminated or they may be objectionable and constitute an unacceptable water source over which Spartanburg Water does not have sanitary control.

Backflow means the undesirable reversal of the intended direction of flow in a potable water distribution system as a result of cross connection.

Spartanburg Water Cross Connection Control Manual

Backpressure means any elevation of pressure in the downstream piping system (caused by a pump, elevated tank or piping, steam, air pressure or any other cause) above the water supply pressure at the point which would cause, or influence, a reversal of the normal direction of flow.

Back-siphonage means the flow of water or other liquid, mixtures, or substances into the potable water system from any source other than its intended source. Back-siphonage is caused by the reduction of pressure in the potable water system.

Backflow Prevention Assembly or Device means an assembly designed and approved to prevent backflow. Types of backflow prevention assemblies include:

(1) **Air gap**: The unobstructed vertical distance through the free atmosphere between the lowest opening from any pipe or faucet conveying water to a tank, plumbing fixture, receptor, and/or the flood rim of the receptacle. The air gap shall be at least twice the diameter of the water supply outlet above the flood rim of the receptacle, and never less than one inch.

(2) **Reduced Pressure Principle Assembly (RP)**: An assembly consisting of two independently acting spring assisted check valves with a hydraulically operating differential relief valve between the check valves and beneath the first check valve. The unit shall have properly located resilient seated test cocks, and resilient seated or ball type shut off valves at each end of the assembly. The assembly shall be readily accessible for in-line testing and maintenance in a location that is never subject to possible flooding. RP devices are approved for high hazard category cross connections. The assembly shall require approval of SCDHEC and Spartanburg Water.

(3) **Double Check Valve Assembly (DCVA)**: An assembly of two independently operating spring assisted check valves with properly located resilient seated test cocks and resilient seated or ball type shut off valves at each end of the assembly. This device shall be readily accessible for in-line testing and maintenance. This assembly is approved for low hazard category cross connections and shall require approval of SCDHEC and Spartanburg Water.

(4) **Double Detector Check Assembly**: A specially designed and approved main line double check valve assembly with a small by-pass line that includes a double check valve assembly and a meter to detect leakage or unauthorized use of water on fire lines.

(5) **Pressure Vacuum Breaker (PVB)**: An assembly of one spring loaded check valve, air inlet valve, ball type shut off valves at each end and two test cocks. This assembly is approved only for back-siphonage. The assembly must be installed 12" above any downstream piping or outlets, or flood level rim. PVB devices are approved for high hazard category cross connections.

(6) **Residential Dual Check**: A device of two independently operating spring assisted check valves. This device is not equipped with shut off valves or test cocks. This device is used for selectively approved low hazard category cross connections. (Residential only) The replacement of these devices will coincide with the meter change out schedule utilized by Field Technical Services.

Spartanburg Water Cross Connection Control Manual

Certified Tester means any person possessing a current SCDHEC tester certification and approved testing equipment.

Contamination means an impairment of the potable water quality by physical, chemical, biological, or radiological substance or matter which creates an actual hazard to public health through poisoning or through the spread of disease.

Cross Connection means any actual or potential connection or physical arrangement between a public water supply and any other source or system through which it is possible to introduce into the potable water system any waste or liquid substance of unknown or unsafe quality other than the intended potable water with which the system is supplied. Bypass arrangements, jumper connections, removable sections, swivel or changeover devices, and other temporary or permanent devices through which or because of which backflow can or may occur are considered to be cross connections.

Customer means any person or premise that receives potable water from Spartanburg Water. Customer will be identified as the following:

- Single Family Dwelling --- requires a dual check device
- Commercial, Industrial and Multi-family dwellings --- each of these sites will be evaluated for degree of hazard and then the appropriate testable assembly will be chosen and installed

Hazard or Degree of Hazard means the determination of the potential risk to public health, and adverse effects upon the potable water system. This risk is defined below in two categories:

(1) **High Hazard/Health Hazard:** An existing or potential threat to the public water supply of a physical or toxic nature that results in a danger to public health.

(2) **Low Hazard/Non-Health Hazard:** A hazard that does not constitute a threat to health, but may cause an actual or potential threat to the physical properties of the water and cause a nuisance or be aesthetically objectionable.

Flood Level Rim means the level from which liquid in plumbing fixtures, appliances, or vats could overflow to the floor, when all drain and overflow openings built into the equipment are obstructed.

Health Official means the South Carolina Department of Health and Environmental Control (SCDHEC)

Industrial Fluids means all types of process and used waters that may be chemically, biologically or otherwise contaminated that would be a health hazard if introduced into the potable water supply.

Potable Water means water from any source which meets the state and federal drinking water standards and which has been approved for human consumption.

Remote High Hazard Fire System means a fire system that has an isolated section with an antifreeze system or other chemical injection system.

Residential Lawn Irrigation (Low Hazard) means any irrigation system on a Single family dwelling that has no chemical injection system or auxiliary water source.

Spartanburg Water Cross Connection Control Manual

Spartanburg Water (SW) consists of the Commissioners of Public Works of the City of Spartanburg, South Carolina, employees of Spartanburg Water, and designated representatives of Spartanburg Water.

Used Water means any water supplied by the Water Purveyor that has passed the water service connection.

Water Purveyor means the owner or operator of a public or private potable water supply.

Water Service Connection means the point where the public potable water system and the customer's water distribution system connect.

SECTION 5 – RESPONSIBILITIES

1. The responsibilities of the Spartanburg Water cross-connection control program are:
 - a. To prevent contamination to the public water system from the introduction of contaminants or pollutants through a service connection. This responsibility begins at the source includes the entire water supply distribution system and ends at the user water service connections. If, in the judgment of Spartanburg Water an approved backflow prevention assembly is required for the safety of the water system, Spartanburg Water will give notice in writing to the customer to have installed such approved backflow prevention assembly(s) at specific location(s) on their premises. Spartanburg Water's preferred method of cross connection control will be containment by installing an approved assembly located immediately downstream of the meter or immediately inside the building and prior to the first connection off the service line. The customer will be required to install such approved assembly(s) at their expense. Failure, refusal, or inability on the part of the customer to install, have tested (as required), and maintained said assembly(s) may constitute grounds for discontinuing water service to the premises until such requirements have been satisfactorily met.

Wholesale customers will comply with these policies at the point of connection to Spartanburg Water system.

- b. To promulgate and enforce policies, regulations, and rules necessary to carry out designated responsibilities.
 - c. To make inspections and determinations of the degree of hazard customers present to Spartanburg Water system.
 - d. To make and maintain all necessary records in accordance with this policy.
 - e. To maintain a list of approved cross-connection prevention assemblies for use in Spartanburg Water system.
2. The responsibilities of water consumers to the cross-connection program are as follows:

Spartanburg Water Cross Connection Control Manual

- a. The water user has the primary responsibility to keep contaminants out of the potable water system. This responsibility begins at the user water service connection and includes any and all water distribution piping on the premises. If a cross-connection or a potential for a cross-connection exists, the water user, at the water user's expense, will be required to install, test (as required), and maintain approved backflow prevention device(s) as required by Spartanburg Water policy.
 - b. The customer should contact Spartanburg Water prior to purchasing or installing a backflow prevention assembly.
 - c. In the event of accidental cross-connection to the Spartanburg Water supply system, the user shall immediately notify Spartanburg Water and must confine further spread of pollution or contamination within the user's premises.
3. The responsibility of the installer of cross-connection prevention assemblies:
 - a. To make sure that each assembly is working properly. The assembly must be tested by a SCDHEC approved tester when installed and prior to the system being placed into service.
 4. The responsibility of the SCDHEC approved Tester:
 - a. An approved tester is an independent contractor who is certified by SCDHEC to test backflow assemblies for SW customers.
 - b. Any test reports not filled out completely or not legible will be rejected.

SECTION 6 - REQUIREMENTS

1. No water service connection to any premises shall be installed or maintained by Spartanburg Water unless the water supply is protected as required by state law and regulations and the SW cross-connection control policy. Service of water to any premise may be discontinued by Spartanburg Water if a backflow prevention assembly required by this cross connection control manual is not installed, tested, and maintained according to requirements, or if it is found that a backflow prevention assembly has been removed, or by-passed, or if an unprotected cross-connection exists on the premises.
2. The customer's system should be open for inspection at all reasonable times to authorized representatives of SCDHEC and Spartanburg Water to determine where cross-connection or other structural or sanitary hazards, including violations of the regulation, exist. When such a condition becomes known, Spartanburg Water may in its sole discretion opt to deny or immediately discontinue water service to the premises.
3. When required, an approved backflow prevention assembly will be installed on each service line to a customer's water system at or near the property line or immediately inside the building being served.

Spartanburg Water Cross Connection Control Manual

4. In the case of premises having (1) internal cross-connections that cannot be permanently corrected and controlled, (2) intricate plumbing and piping arrangements, or (3) where entry to all portions of the premises is not readily accessible for inspection purposes, making it impractical or impossible to ascertain whether or not hazardous cross-connections exist, Spartanburg Water distribution system shall be protected against backflow from the premises by installing and approved backflow prevention assembly in the service line.
5. Any backflow prevention assembly required herein will be a model and size approved by Spartanburg Water. See appendices (A) in the back of the manual.

SECTION 7 - DEGREE OF HAZARD

The type of protective assembly required will depend upon the degree of the hazard that exists as follows:

- a. In the case of any premises where there is any material hazardous to health that is handled in such fashion as to create an actual or potential hazard to Spartanburg Water system, Spartanburg Water system will be protected by an approved air-gap separation or an approved reduced-pressure principle backflow prevention assembly. Examples of premises where these conditions will exist include sewage treatment plants, sewage pumping stations, chemical manufacturing plants, hospitals, mortuaries, and plating plants.
- b. In the case of any premises where there is water or a substance that would be objectionable but not hazardous to health if introduced into Spartanburg Water system, Spartanburg Water system will be protected by an approved double-check valve assembly.

SECTION 8 - INSTALLATION

8.1 New Connections

1. When the application and purchase is made for the water service connection, the customer will provide information regarding the use of the water at the new connection. Spartanburg Water will evaluate the new service to determine the type of backflow prevention assembly required (if any).
2. The customer will be notified of the backflow prevention assembly requirements, including an installation timeline.
3. The customer will have the backflow prevention assembly completely installed according to all Spartanburg Water requirements found in the manual of cross connection control (See Appendix (A) & (B)) All Spartanburg Water and SCDHEC and manufacturers' installation requirements will be met.
4. Spartanburg Water will make a site inspection and if the installation is found to be satisfactory the meter or service will be unlocked and turned on. If installation deficiencies are found during the inspection, the customer will be notified to correct all such deficiencies and a follow up inspection will be completed before the water service is turned on.

8.2 Existing Service Connections

Spartanburg Water Cross Connection Control Manual

1. Existing service connections will be evaluated by Spartanburg Water to determine the type of backflow prevention assembly required (if any).
2. Spartanburg Water will make an appointment with the water customer for a site survey. In selected cases a site survey may not be necessary. Spartanburg water may, in its sole discretion, waive the site survey in selected cases.
4. The customer will be notified of the backflow prevention assembly requirements, including an installation deadline.
5. The customer will have the backflow prevention assembly completely installed according to all Spartanburg Water requirements found in the manual of cross connection control (See Appendix (A) & (B)) All Spartanburg Water and SCDHEC and manufacturers' installation requirements will be met.
6. The customer will notify Spartanburg Water at least 7 calendar days prior to the required inspection.

8.3 Right of Entry

Whenever it shall be necessary for the purpose of compliance or enforcement of the policy, Spartanburg Water and/or SCDHEC representatives may enter upon any property or premises at reasonable times for the purpose of:

- a. Inspection of any equipment or water lines
- b. Sampling of any water suspected of any cross-connection.

Spartanburg Water and/or SCDHEC may enter upon the property at any hour under emergency circumstances to perform any investigation required to enforce this Policy.

8.4 Wells

Any building presently being served from a private well must physically disconnect from the well prior to Spartanburg Water System metered service being turned on for use.

- The well can be maintained for outdoor use. If the customer desires the well to remain connected to the SW meter service, a reduced pressure backflow prevention device must be installed on the service line, on the customer side of the water meter by the customer as outlined in section 8.1 of this manual.

SECTION 9 - INSTALLATION REQUIREMENTS

9.1 Hazard Applications

1. **High Hazard/Health Hazard** connections require reduced pressure principle assemblies, pressure vacuum breakers (for back-siphonage hazards only), or an air gap for prevention of backflow.

Spartanburg Water Cross Connection Control Manual

2. **Low Hazard/Non-health Hazard** connections require double check valve assemblies or double detector valve assemblies for prevention of backflow.

9.2 Location

Installation of the assemblies will usually be in a structure near the water meter or inside a building in a mechanical area, and prior to the first connection off the service line. The Spartanburg Water will review each site and make a recommendation for the location of the assembly.

9.3 RP and DCVA Installation Requirements

1. The assembly must appear on the Spartanburg Water list of approved backflow prevention assemblies. See Appendices (A.) & (B)
2. No by-pass is permitted around the assembly unless there is an equal backflow prevention assembly in the by-pass. Customers with situations that prohibit shutting off the water service to test or repair the assembly should install a backflow prevention assembly in parallel or install a separate parallel duplicate service line with proper backflow protection.
3. All manufacturers' installation requirements will be consulted and followed including hot water and high pressure applications.
4. Requirements for height and side clearance must comply with Appendix (B)
5. All backflow prevention assemblies will be installed in an enclosure or building on the customer's property to prevent damage from freezing, traffic or vandalism, and will be readily accessible for testing and maintenance.
6. The customer will design and install adequate thrust restraints. Upon inspection, Spartanburg Water may require additional thrust restraints where deemed necessary.
7. The customer will design and install adequate pipe supports. Upon inspection Spartanburg Water may require additional pipe supports where deemed necessary.
8. A strainer may be needed as recommended by the manufacturer to prevent particles from fouling the check assemblies.
9. No black iron/black steel piping will be installed on the supply side of any backflow prevention assembly

9.4 Additional Requirements for RPs

1. Conditions may exist where periodic pressure fluctuations cause the relief valve of the assembly to discharge to the point of becoming a nuisance. In this event, the customer should install an additional check valve prior to the assembly.
2. Relief valve drain piping must meet approved air gap requirements. The air gap distance requirement is equal to two (2) times the relief valve diameter or 1-inch, whichever is greater. The piping will be sized to exceed the discharge rate of the relief valve.
3. The relief valve will never become submerged.
4. Underground installations of reduced pressure principle backflow assemblies are discouraged. Underground installations are only permitted in exceptional circumstances on a case by case basis and only where an adequately sized gravity drain can be installed.

9.5 Fire Suppression/Fire Sprinkler Systems

Spartanburg Water Cross Connection Control Manual

Each private fire protection system will be evaluated by site and/or plan survey for degree of hazard. Backflow prevention assemblies commensurate with the degree of hazard will be required on all connections to Spartanburg Water.

High Hazard/Health Hazard Category: Systems that are considered to be in the High Hazard/Health Hazard Category include, but are not limited to: antifreeze systems, foam injection systems and systems supplied from or connected to lakes, ponds, streams, or any other source other than Spartanburg Water. High hazard category fire protection systems will require a Reduced Pressure assembly or Air Gap on any connection to Spartanburg Water as close as possible to the service connection and the property line.

A remote high hazard fire system is a fire system that has an isolated section with an antifreeze system or other chemical injection system. It is acceptable to protect this type of fire system with a Reduced Pressure assembly at the site of the chemical addition or at the water connection.

Low Hazard/Health Hazard Category: Systems that are considered to be in the Low Hazard/Health Hazard Category of fire protection systems will include simple wet or dry fire sprinkler systems. These systems may also include covered storage tanks or pumps supplied by the Spartanburg Water. A Double Detector Check Assembly is required on any connection to the Spartanburg Water as close as possible to the service connection and the property line.

In isolated cases the backflow prevention assembly must be installed inside the building. A Double Check Valve assembly will be installed on the riser piping immediately above the floor. This must be included on the building drawings and approved in writing by Spartanburg Water.

9.6 Removal of Assembly

No backflow prevention assembly will be removed, by-passed, or downgraded without prior written approval of the Spartanburg Water.

SECTION 10 - TESTING REQUIREMENTS

10.1 Residential Lawn Irrigation Systems

Low Hazard/Health Hazard: Spartanburg Water requires all customers who operate low hazard residential lawn irrigation systems to install as a minimum a dual check valve assembly for backflow prevention. The assembly will be replaced in conjunction with the meter change-out program or if malfunction of the assembly occurs.

High Hazard/Health Hazard: Regulations require that high hazard residential lawn irrigation systems must comply with the requirements of a high hazard cross connection. This includes the installation and maintenance of a reduced pressure assembly. Annual testing of this device is required by regulation.

10.2 Testing of Assemblies

Spartanburg Water Cross Connection Control Manual

All existing approved backflow assemblies, excluding low hazard residential lawn irrigation systems, are required to be tested annually or as deemed necessary to comply with Spartanburg Water or Department of Health and Environmental Control (DHEC) requirements.

Customers with backflow assemblies will be sent a notification letter (Tier 1) by Spartanburg Water 30 days prior to the date the test is due to be completed. The due date for the test is the last day of the month. Upon notification the customer is responsible for getting the assembly(s) tested utilizing a SW approved tester. The customer is responsible for ensuring that the tester tests the assembly by the due date and transmits the test report indicating compliance to Spartanburg Water within 7 days of the actual date the device is tested.

If Spartanburg Water has not received the completed test report indicating compliance within 14 days after the due date, a second notification letter (Tier 2) will be sent to the customer requiring the completed test reports be received within 14 calendar days or the customer will be considered non-compliant. If SW still has not received the test reports at the end of this 14 calendar day period the third and final letter (Tier 3) will be sent notifying the customer that one of the following actions will take place after 14 calendar days have passed:

- SW will hire a SCDHEC approved tester who will test the assembly and their labor, parts and an administrative fee will be added to the water bill.
- If access to the assembly is not available SW may in its sole discretion opt to suspend services

10.3 Test Failures

If tested assembly(s) fail the required tests indicating compliance and cannot be repaired immediately the tester will return a copy of the failed test report to Spartanburg Water the same day of the failed test with an explanation of the test failure and the repair(s) needed. Failing assemblies must be satisfactorily repaired or replaced, completely retested and the reports submitted to SW within 10 business days of the date of the test failure. If during this time Spartanburg Water determines the potable water supply is at risk of a potential backflow or cross connection as the result of the failed backflow assemble(s) the water service shall be disconnected immediately. If an extension of time will be needed to complete repair/replacement and retesting, the tester or customer must request the extension within 3 business days of the test failure. SW will notify the customer and/or the tester that an extension is granted and for how long, or that no extension is granted. Granting or denial of any extension shall be at Spartanburg Water's sole discretion.

After the assembly is repaired or replaced the assembly will be retested and the completed test report indicating compliance will be returned to Spartanburg Water.

10.4 Testing Non-Compliance

Customers with backflow assemblies will be considered non-compliant when:

- Completed test reports indicating compliance are not received by the 14th calendar day after the end of the month due date.

Spartanburg Water Cross Connection Control Manual

- Failing assemblies not satisfactorily repaired or replaced, retested and test reports indicating compliance submitted within 10 business days of the original date of the test failure, unless an extension of time has been granted in writing by Spartanburg Water
- Failing assemblies that require replacement will be held to the completion schedule as outlined in the Test Failures sections.

Failure to comply with the testing, repairing, replacement and retesting requirements as stipulated within this section may result in the following options:

1. Assemblies located at the property line or meter and/or readily accessible will be tested by SW as described in Testing of Assemblies

The non-compliant customer(s) will assume all of Spartanburg Water's costs associated with the testing, repairing, retesting and/or replacement of the device(s) plus a fifty dollar (\$50.00) administrative fee to recover the costs involved in the handling, administration, and billing of the test. These costs will be added to the customer's water bill.

2. If access to the assembly is not available SW may in its sole discretion opt to suspend water services .
:

SECTION 11 - NON-COMPLIANCE/ENFORCEMENT

11.1 Enforcement Authority

Pursuant to authority granted by the General Assembly of South Carolina in 1896, The Commissioners of Public Works of the City of Spartanburg (Spartanburg Water System) has the authority to build, maintain, and operate facilities needed to meet the water supply needs of its service area. Under its statutes, Spartanburg Water System (SWS) has the responsibility and legal right to take all action necessary to maintain and protect its water system.

The remedies provided in this section are not exclusive. Spartanburg Water System (SWS) reserves the right to take any other action, either more or less stringent, that SWS determines to be appropriate against any user or person for any violation of any provision of this Cross Connection Control Manual, federal, state and local requirements, permit, or orders or directives issued. Further, SWS is empowered to take more than one enforcement action concurrently against any person who is in noncompliance.

Criminal Prosecution

Spartanburg Water Cross Connection Control Manual

This Cross Connection Control Manual is a regulation of SWS. Under Section 22-102 of the Spartanburg Municipal Code, SWS regulations are enforceable as Spartanburg city ordinances with fines of up to \$500 or 30 days imprisonment per violation. See S.C. Code Ann. § 5-7-30.

Under other statutes, tampering with the property or appurtenances of SWS's system is a criminal offense. See S.C. Code Ann. § 5-31-1120.

It is a crime to pollute the water supply of any city water system. See S.C. Code Ann. § 5-31-1130.

These offenses can result in criminal fines of up to \$200 and 60 days imprisonment per violation. See S.C. Code Ann. § 5-31-1170.

In addition, The State Safe Drinking Water Act (SC Code Title 44, Chapter 55, Article 1, contains the following provisions:

SECTION 44-55-80. Unlawful acts.

(A) It is unlawful for a person to fail to comply with:

- (1) the provisions of this article or the regulations promulgated pursuant to this article;
- (2) the conditions of any permit issued under this article; or
- (3) any order of the department (SC Department of Health and Environmental Control).

(B) It is unlawful for a person to render a public water system, or part or portion of a public water system, inoperable or unusable by means of contamination, vandalism, sabotage, or assault upon or detention of employees of the system or to misrepresent any fact related to the operation of a public water system.

SECTION 44-55-90. Penalties; injunctive relief.

(A) Any person willfully violating the provisions of Section 44-55-80 is guilty of a misdemeanor and, upon conviction, must be fined not more than ten thousand dollars a day per violation or imprisoned for not more than one year, or both.

(B)

- (1) A violation of Section 44-55-80 by a person renders the violator liable to the State for a civil penalty of not more than five thousand dollars a day per violation.
- (2) The department (SC Department of Health and Environmental Control) may administer penalties as otherwise provided for violations of this article, including any order, permit, regulation, or standard or may request the Attorney General to commence an action under this subsection in an appropriate court of the State to secure this penalty.

Spartanburg Water Cross Connection Control Manual

(C) The department (SC Department of Health and Environmental Control) may cause to be instituted a civil action in any court of applicable jurisdiction for injunctive relief to prevent violation of this article or any order issued pursuant to Sections 44-55-40, 44-55-60, and 44-55-70.

Spartanburg Water will cooperate fully with any lawful state or federal agency enforcement action.

Falsifying Information

Any person who knowingly makes any false statements, representation or certification in any application, record, report, plan, or other document filed or required to be maintained pursuant to this Cross Connection Control Manual may be subject to penalties as outlined in Section 11.

Civil Remedies

SWS may recover:

- the cost of any actual damages incurred by SWS;
- the cost of testing devices to meet requirements of this manual;
- reasonable consultants', professionals' and attorneys' fees and court costs;
- any other expenses associated with enforcement activities;
- administrative fees as provided by law or regulation.

11.2 Enforcement Procedure

Non-compliance may result in enforcement procedures follows:

- a. Existing water customers who do not have a cross-connection control assembly(s) in their system at present, but will be required to install such an assembly under this policy. Customers in this category where contaminants on their property have been determined by Spartanburg Water to represent a health hazard to the public water system will be required to take immediate corrective action upon notification. Customers will be required to install an approved backflow prevention assembly within thirty (30) days of notification from Spartanburg Water.
- b. Failure of any new water customer to install an approved backflow prevention assembly prior to connection to Spartanburg Water distribution system whenever Spartanburg Water has determined that contaminants or pollution on the customer's property represents a hazard to the public water system. SW may in its sole discretion opt to suspend water services

Spartanburg Water Cross Connection Control Manual

- c. Those existing water customers who have required backflow prevention assembly (s) in their system which do not meet Spartanburg Water requirements will be required to replace backflow prevention assembly(s) with assemblies that meet Spartanburg Water requirements. Failing backflow prevention assemblies must be repaired or replaced by the customers with an approved backflow prevention assembly within ten (10) days after notification by Spartanburg Water or grant an extension of time.

11.3 Termination of water service/Reconnect fees

- a. Service of water to any premises may be discontinued by Spartanburg Water for the following reasons: (1) if a backflow prevention assembly that is required by law, rules, or regulations is not installed, tested, and maintained, (2) if it is found that a backflow prevention device has been removed or by-passed, or (3) if unprotected cross-connection exists on the premises and there is inadequate backflow protection at the service connections. Water service will not be restored until such conditions and defects are corrected.
- b. Water services may be terminated for water customers who do not comply with Spartanburg Water cross connection control policy. A written notice will be provided to the customer that water service will be terminated within ten (10) days if the requirements of this policy are not met.
- c. The customer will be responsible for all applicable reconnection fees and charges. Spartanburg Water will not be liable for damages, losses, or claims arising from discontinuance of water service.

11.4 Legal Action

After the evidence has been reviewed and a decision rendered with a copy to the customer, Spartanburg Water may terminate water service and/or pursue any available legal remedy.

Spartanburg Water reserves the right to perform any action or combination of action(s) it deems necessary as remedies of compliance with this manual, any other local, state, and federal requirement(s) involving cross-connection control within its system.

SECTION 12 – APPEALS

Customers, contractors, or other individuals that disagree with any requirement of the Spartanburg Waters Cross Connection Control Policy or requirements imposed by Spartanburg Water may appeal any requirement to the Commissioners of Public Works of the City of Spartanburg, South Carolina. Any appeal must be submitted in writing to the Spartanburg Water Chief Executive Officer or her/his designee a minimum of two weeks in advance of any regularly scheduled Commission Meeting. The individual making the appeal will be given the opportunity to appear before the Commission to present their appeal.

After review and any investigation necessary, the Commission will notify the individual of a decision, which will be final.

Spartanburg Water Cross Connection Control Manual

SECTION 13 – THERMAL EXPANSION

There are several regulatory agencies that require Spartanburg Water to maintain a viable Cross Connection Control Program. Backflow can occur from all industrial, commercial, or residential water service connections. Since 1971, backflow prevention assemblies have been installed on many service connections. In 1985, the Spartanburg Water began installing residential dual check valves on ¾” services. These practices continue today in an effort to prevent backflow from all size services from entering the public potable water supply.

Practically all customers utilize heated water in their plumbing system. When water is heated, its physical character changes and it expands. This expanded water needs to occupy more space. Before backflow preventers or dual check valves were installed on service lines, this expanded water expanded back into the Spartanburg Water’s distribution system. This was known as an open system. This is no longer possible where a backflow preventer or a dual check is present. This is known as a closed system. The condition of heated water expanding in a closed system is known as Thermal Expansion. Often, thermal expansion will cause water heater Temperature and pressure Relief Valves to discharge excessive water pressures, usually at above 150 psi.

The three most popular methods of dealing with the effects of thermal expansion are: installing a bladder type expansion tank, a special ball cock and relief valve in the water closet, or a remote thermal expansion relief valve. The SWS suggests you discuss these alternatives with a licensed plumber. These three methods can be “do it yourself” projects.

The Spartanburg Water will make its best effort to continue to provide safe potable water to all customers. Backflow prevention assemblies are a necessary means to protect the Spartanburg Water’s water distribution system. If you have any questions concerning thermal expansion as it relates to cross connection control, call 864-585-8296.

ATTACHMENTS



BACKFLOW PREVENTION ASSEMBLY FIELD TESTING AND MAINTENANCE REPORT

Return to: Spartanburg Water
C&D Department
301 South Avenue
Spartanburg, SC 29306

Phone: (864) 253-9304 Fax: (864) 596-4927

Date: ___/___/___ Account No.: _____ Meter No.: _____
Customer/Business Name: _____
Customer Address: _____
Customer Contact Person: _____ Customer Phone #: _____

Assembly Information: ___ RP ___ DCVA ___ DCDA ___ PVB
Size: ___ Manufacturer: ___ Model #: ___ Serial #: _____
Location (hazard protected) _____

___ Vertical ___ Horizontal Assembly By-passed ___ Yes ___ No
Comments: _____

TEST RESULTS

	Check No. 1	Check No. 2	Differential Relief Valve or Air Inlet	No. 1 Gate or Ball (Circle One)	No. 2 Gate or Ball (Circle One)
Test Before Repair	(Mark One) ___ Leaked ___ Shut Tight Differential Pressure ___	(Mark One) ___ Leaked ___ Shut Tight Differential Pressure ___	Open at ___ lbs. Differential Pressure	(Mark One) ___ Leaked ___ Shut Tight	(Mark One) ___ Leaked ___ Shut Tight
Repair And New Materials	Comments: Date: ___/___/___	Comments: Date: ___/___/___	Comments: Date: ___/___/___	Comments: Date: ___/___/___	Comments: Date: ___/___/___
Test After Repair	(Mark One) ___ Leaked ___ Shut Tight Differential Pressure ___	(Mark One) ___ Leaked ___ Shut Tight Differential Pressure ___	Open at ___ lbs. Differential Pressure	(Mark One) ___ Leaked ___ Shut Tight	(Mark One) ___ Leaked ___ Shut Tight

Test Method: ___ Direction of Flow or ___ Differential Pressure
Test Kit Used: ___ Vert. Tube or ___ Differential Model: _____

I hereby certify that the above information is correct and that the test and repairs were performed by myself as duly certified by the South Carolina Department of Health and Environmental Control as a General Tester or Limited Tester.

Tester Name (Print) _____ Signature _____
Certification # _____ Company _____ Phone # _____
Category: ___ General Tester ___ Limited Tester ___ Inspector-Tester

Owner Certification

I hereby certify that the above assembly has been in constant use at the location in conformance with the policies of the Spartanburg Water System. I further certify that this assembly has not been removed or by-passed without notification and authorization by the Spartanburg Water System. A copy of this report has been retained in my files.

Signature: _____ Date: ___/___/___

APPENDIX A-5



CROSS CONNECTION QUESTIONNAIRE

Tap#:

Customer Name:

Customer/Account #:

Builder:

Application Date:

Service Address:

Lot#:

Subdivision:

Mail-To Address:

Telephone: () -

Name of Plumber or Individual that can answer questions regarding water usage at this location:

Telephone#:

Type Service:

Irrigation:

Meter Size:

Will Meter be Locked:

Is there a well or other source of water on site:

If yes, notified customer of well requirements:

Dedicated Irrigation:

Will irrigation be added to domestic meter:

If irrigation, will chemical injection be possible:

If irrigation, is a well or other source of water on site:

Business/Site Activity:

Will chemicals be used on site:

Will recycled/reclaimed water be used on site:

Is medical treatment taking place:

Possibility of exposure to biological hazards/body fluids:

X _____

Applicant Signature

THE COMMISSION OF PUBLIC WORKS
OF THE CITY OF SPARTANBURG SC

Horace C. Littlejohn, Jr.
John D. Montgomery
Angela M. Viney

Sue G. Schneider, Chief Executive Officer G.
Newton Pressley, Chief Financial Officer
Robert F. Walden, Chief Operating Officer
Charles E. Jackson, Capitol Projects Officer



SPARTANBURG SANITARY SEWER
DISTRICT COMMISSION

Barbara J. Barnes
Louie W. Blanton
Horace C. Littlejohn, Jr.
A. Manning Lynch, Jr.
John D. Montgomery
Angela M. Viney
Junie White

<Person>

<Business>

<Address>

<City, State, Zip Code>

<Date>

Test Rejection Form

Reference: <Business>

The enclosed Backflow test reports are rejected. The form requires the information indicated below. Please rectify and return completed information within 10 business days as outlined in section 10.3 of the CCC manual.

Date___ Customer Name___ Address___ Assembly Type___ Size___ Manufacturer___

Model#___ Serial#___ Location___ Test Method___ 1 or 2 Check results___

1 or 2 Check Differential___ 1 or 2 Gate type___ 1 or 2 Gate Results___ Test kit Model #___

Repairs performed___ Results after repair___ Certification#___ Category___ Owner Signature___

Relief Valve ___ Other: _____

If you have any questions, call me at (864) 253-9304.

Sincerely,

SPARTANBURG WATER SYSTEM

CCC Program Technician

THE COMMISSION OF PUBLIC WORKS
OF THE CITY OF SPARTANBURG, SC

Horace C. Littlejohn, Jr.
John D. Montgomery
Angela M. Viney

Sue G. Schneider, Chief Executive Officer G.
Newton Pressley, Chief Financial Officer
Robert F. Walden, Chief Operating Officer
Charles E. Jackson, Capitol Projects Officer



SPARTANBURG SANITARY SEWER
DISTRICT COMMISSION

Barbara J. Barnes
Louie W. Blanton
Horace C. Littlejohn, Jr.
A. Manning Lynch, Jr.
John D. Montgomery
Angela M. Viney
Junie White

<Person> <Date>
<Business>
<Address>
<City, State, Zip Code>

Reference:

Dear Customer:

The Federal Safe Drinking Water Act of 1974 and South Carolina State Primary Drinking Water Regulations promulgated pursuant to Section 44-55-30 through 44-55-60 of the 1976 South Carolina Code of Laws, Regulation 61-58.7(F) require that the water purveyor, in this case Spartanburg Water, has the primary responsibility for preventing water from unapproved sources, or any other substances, from entering the public potable water system. Per regulation, "no person shall install, permit to be installed or maintain any cross connection between a public water system and any other non-public water system, sewer, or a line from any container or liquids or other substances, unless an approved backflow prevention device or assembly is installed between the public water system and the source of contamination."

Currently there is no backflow prevention assembly installed at the location referenced above. Please adhere to the steps outlined in Section 8 Installation of the Spartanburg Water Cross Connection Control Manual and have the necessary assembly based on hazard installed within 10 days of the date of this letter.

Spartanburg Water will terminate water service to this location in accordance with Section 10.3 "Test Failures" of the Spartanburg Water Cross Connection Control Manual. You may view the manual at:
https://www.spartanburgwater.org/files/files/Spartanburg%20Water_CCC_Manual_revised9.25.2018.pdf

If you have any questions, please contact Corey Reid at (864) 598-7203 or email creid@spartanburgwater.org.

Sincerely,
SPARTANBURG WATER

Corey Reid
Distribution/Cross Connection Control Manager

THE COMMISSION OF PUBLIC WORKS
OF THE CITY OF SPARTANBURG, SC

Horace C. Littlejohn, Jr.
John D. Montgomery
Angela M. Viney

Sue G. Schneider, Chief Executive Officer G.
Newton Pressley, Chief Financial Officer
Robert F. Walden, Chief Operating Officer
Charles E. Jackson, Capitol Projects Officer



SPARTANBURG SANITARY SEWER
DISTRICT COMMISSION

Barbara J. Barnes
Louie W. Blanton
Horace C. Littlejohn, Jr.
A. Manning Lynch, Jr.
John D. Montgomery
Angela M. Viney
Junie White

<Person>

<Business>

<Address>

<City, State, Zip Code>

<Date>

Reference: <Business>

Dear Customer:

In reference to at the above location Spartanburg Water has the primary responsibility for the prevention of backflow into the public water supply system. This responsibility begins at the water treatment facilities, includes the entire water distribution piping system and ends at the water service connection. Spartanburg Water's primary method of cross connection control shall be by containment; by having the customer install an approved backflow prevention assembly at the water service connection usually immediately downstream of the meter.

The customer is responsible for preventing backflow from entering the Spartanburg Water System's distribution system and from entering the customer's water system. The customer at his cost shall install, test and maintain all backflow prevention assemblies as required.

After reviewing the questionnaire, site drawings and or making a site visit SW will require the following SCDHEC approved backflow assembly(s) or device(s):

The meter box will be locked by SW upon installation. When you have the assembly installed, contact SW CCC Technician to schedule an inspection. The meter box will be unlocked and meter turned on if installation has met requirements outlined in section 8.1 of the CCC Manual. If you have any questions, call me at (864) 598-7214.

Sincerely,

SPARTANBURG WATER SYSTEM

THE COMMISSION OF PUBLIC WORKS
OF THE CITY OF SPARTANBURG SC

Horace C. Littlejohn, Jr.
John D. Montgomery
Angela M. Viney

Sue G. Schneider, Chief Executive Officer G.
Newton Pressley, Chief Financial Officer
Robert F. Walden, Chief Operating Officer
Charles E. Jackson, Capitol Projects Officer



SPARTANBURG SANITARY SEWER
DISTRICT COMMISSION

Barbara J. Barnes
Louie W. Blanton
Horace C. Littlejohn, Jr.
A. Manning Lynch, Jr.
John D. Montgomery
Angela M. Viney
Junie White

<Person>
<Business>
<Address>
<City, State, Zip Code>

<Date>

ANNUAL BACKFLOW PREVENTER TEST

Reference: <Business>

Dear Customer:

Our records indicate that the Backflow Prevention Assemblies on your property are due for their annual test as outlined in section 10.2 of the CCC manual. The South Carolina Department of Health and Environmental Control (SCDHEC) and Spartanburg Water requires each assembly be tested at least annually by a tester certified by SCDHEC. For a list of General Certified Testers go to the following website.
<http://www.scdhec.gov/EnvironmentDocs/BackFlow/general%20tester%20list.pdf>

The assemblies requiring this annual test are listed on the attached sheet. Please furnish your tester with this sheet and the enclosed test reports. Notify the certified tester of any possible alarms or fixtures that may be affected by having the water supply turned off while this test is performed.

Return the completed test reports to the Cross Connection Control Division at (301 South Ave. Spartanburg , SC 29306) by the test due date. If the assembly fails the required tests, repairs must be completed within 10 days. Retain copies of completed reports for your files.

Customers that fail or refuse to test or return completed test reports will be considered in non-compliance as outlined in the Spartanburg Water Manual of Cross Connection Control. Any reconnection fees, testing fees, or penalty charges will be the responsibility of the customer.

If you have any questions, call me at (864) 253-9304.

Sincerely,

SPARTANBURG WATER SYSTEM

Corey Reid, Program Manager

THE COMMISSION OF PUBLIC WORKS
OF THE CITY OF SPARTANBURG SC

Horace C. Littlejohn, Jr.
John D. Montgomery
Angela M. Viney

Sue G. Schneider, Chief Executive Officer G.
Newton Pressley, Chief Financial Officer
Robert F. Walden, Chief Operating Officer
Charles E. Jackson, Capitol Projects Officer



SPARTANBURG SANITARY SEWER
DISTRICT COMMISSION

Barbara J. Barnes
Louie W. Blanton
Horace C. Littlejohn, Jr.
A. Manning Lynch, Jr.
John D. Montgomery
Angela M. Viney
Junie White

<Person>
<Business>
<Address>
<City, State, Zip Code>

<Date>

ANNUAL BACKFLOW PREVENTER TEST

Reference: <Business>

Dear Customer:

At this time, the Spartanburg Water System has not received the completed test report forms for the backflow prevention devices on your property. These test reports are now past due as described in section 10.2 of the CCC Manual. Please have a certified tester make the required tests, and return the completed test reports to us for our files.

If you have any questions, call me at (864) 253-9304.

Sincerely,

SPARTANBURG WATER SYSTEM

Corey Reid, Program Manager

THE COMMISSION OF PUBLIC WORKS
OF THE CITY OF SPARTANBURG SC

Horace C. Littlejohn, Jr.
John D. Montgomery
Angela M. Viney

Sue G. Schneider, Chief Executive Officer G.
Newton Pressley, Chief Financial Officer
Robert F. Walden, Chief Operating Officer
Charles E. Jackson, Capitol Projects Officer



SPARTANBURG SANITARY SEWER
DISTRICT COMMISSION

Barbara J. Barnes
Louie W. Blanton
Horace C. Littlejohn, Jr.
A. Manning Lynch, Jr.
John D. Montgomery
Angela M. Viney
Junie White

<Person>
<Business>
<Address>
<City, State, Zip Code>

<Date>

ANNUAL BACKFLOW PREVENTER TEST

Reference: <Business>

Dear Customer:

At this time the Spartanburg Water System (SWS) has not received any response from our previous notices for the required annual testing of the backflow prevention assemblies on your property. Therefore the water service to this property is in non compliance as outlined in Section 10 of the SWS Cross Connection Control Manual.

The SWS will proceed with non compliance regulation 10.4 described below:

Failure to comply with testing, repairing, replacement and retesting requirements as stipulated within this section may result in the following options:

1. Assemblies located at the property line or meter and /or readily accessible will be tested by SW as described in Testing of Assemblies 10.2
2. If access to the assembly is not available SW may in its sole discretion may opt to suspend water service
3. **The non-compliant customer(s) will assume all of the Spartanburg Water's costs associated with the testing, repairing, retesting and/or replacement of the device(s) plus a (\$50.00) administrative fee to recover the cost involved in the handling, administration and billing of the test. These cost will be added to the customer's water bill.

If you have any questions, call me at (864) 253-9304.

Sincerely,

SPARTANBURG WATER SYSTEM

Corey Reid, Program Manager

Appendix A-2.0
 SPARTANBURG WATER SYSTEM
 Approved Backflow Prevention Assemblies
LIST OF LEAD FREE DOUBLE CHECK VALVE ASSEMBLIES

The following is a partial list of **Lead Free Double Check Valve Assemblies** (LFDCVA) approved for use to protect a potable water supply. These assemblies are limited to only **Low Hazard or Non-Health Hazard** category backflow protection. Low Hazard or Non- Health Hazard shall mean an actual or potential threat to the physical properties of the public or consumers' water system but not a danger to health. The greatest degradation of the public water supply would be of a nuisance or aesthetically objectionable nature.

COMPANY	MODEL	SIZES
AMES	LF2000B	½" – 2"
AMES	C200 and C200N	2 ½"-10"
AMES	M200 and M200N	2 ½"-10"
APOLLO / CONBRACO	DCLF4A	½" – 12"
APOLLO /CONBRACO	DCLF4An	2½"-12"
APOLLO /CONBRACO	DC4SGLF	2 ½" – 6"
FEBCO	LF850	½"-10"
FEBCO	LF850U	½"-2"
FEBCO	LF870V	2 ½"-8"
WATTS	LFOO7	½" - 3"
WATTS	LF719QT	½"-2"
WATTS	LF757 and LF757N	2 ½"-10"
WATTS	LF709	2½" – 10"
WILKINS	350XL	¾"-2"
WILKINS	950 XLT2	¾"-2"
WILKINS	350A, 350AST and 450	2½" – 10"
WILKINS	350	2½" – 12"

NOTE: This is a partial list of approved LEAD FREE DCVA assemblies. Some models are also available in "N" or "Z" configurations. Other models may have previous approvals and may still be available from suppliers. Other models may have gained recent approval. Please call to check on approval of a specific model not listed.

REVISION, November 2016

Appendix A-2.1

Appendix A-3
 SPARTANBURG WATER SYSTEM
 Approved Backflow Prevention Assemblies
LIST OF LEAD FREE REDUCED PRESSURE PRINCIPLE ASSEMBLIES

The following is a list of **Lead Free Reduced Pressure Principle Assemblies (RP)** for use to protect the potable water supply. These assemblies shall be used for **High Hazard or Health Hazard** category cross connection control. High Hazard or Health Hazard category shall mean an actual or potential danger to a potable water system of a toxic nature or danger to health.

COMPANY	MODEL	SIZE
AMES	LF4000B	½"-2"
AMES	C400 , C400N & C400Z	2 ½"-10"
AMES	M400 , M400N & M400Z	2 ½"-10"
APOLLO / CONBRACO	RP4ALF	½"-12"
APOLLO / CONBRACO	RP4An	2½" – 12"
FEBCO	LF825Y and LF825YA	¾"-2"
FEBCO	LF860	½"-10"
FEBCO	LF860U	½" – 2"
FEBCO	LF 880V	2 ½"-10"
WATTS	LF009	¼"-3"
WATTS	LF909	¾"-10"
WATTS	LF919	¾"-2"
WATTS	957, 957N & 957Z	2 ½"-10"
WILKINS	375XL	½" – 2"
WILKINS	975XL2	¼"-2"
WILKINS	375, 375A & 375AST	2 ½"-10"
WILKINS	475 & 475V	2½" – 10"

NOTE: This is a partial list of approved RP assemblies. Other models may have previous approvals and may still be available from suppliers. Other models may have gained recent approval. Please call to check on approval of a specific model not listed.

RP assemblies are not approved for vertical installations. Some models come in “N” or “Z” configurations that allow vertical piping.

RP assemblies can not be installed where the relief valve may become submerged.

Backflow Prevention Assemblies
LIST OF DOUBLE CHECK DETECTOR ASSEMBLIES
 SPARTANBURG WATER SYSTEM

Approved

The following is a list of **Double Check Detector Assemblies (DCDA)** approved for use to protect the potable water system. The DCDA shall be used on **Low Hazard, Non-Health Hazard** fire suppression systems. Low Hazard, Non-Health Hazard fire suppression systems shall consist of air or water only systems with no chemical or anti-freeze additives or no connections to an unapproved water source such as a pond, stream or well.

DCDA assemblies are to be type 1 with gallon meters installed when there is underground piping between the location of the backflow assembly and the building. If the alarm valve is installed immediately downstream of the backflow assembly as may be done on the fire riser in a building then a DCVA listed on Appendix A-2.0 shall be used. SWS should be consulted for approval for the location of the assembly.

If the fire suppression system is of the High Hazard, Health Hazard category then **Reduced Pressure Principle (RP)** assemblies found on appendix A-3

COMPANY	MODEL	SIZE
AMES	C300 and C300N	2 ½"-10"
AMES	M300 and M300N	2 ½"-10"
APOLLO / CONBRACO	DCDA4A & DCDA4An	2½" – 12"
APOLLO / CONBRACO	DCDA4SG	2 ½"-10"
FEBCO	856ST	2 ½"-10"
FEBCO	876VST	2 ½"-10"
WILKINS	350DA,	2 ½"-12"
WILKINS	350ADA & 350ASTDA	2½" – 10"
WILKINS	450DA	4" – 10"
WATTS	757DCDA and 757NDCDA	2 ½"-10"
WATTS	709DCDA	3" – 10"

NOTE: This is a partial list of approved DCDA assemblies. Some models are also available in “N” or “Z” configurations. Other models may have previous approvals and may still be available from suppliers. Other models may have gained recent approval. Please call to check on approval of a specific model not listed.

REVISION, November 2016

Appendix A-2.0
 SPARTANBURG WATER SYSTEM
 Approved Backflow Prevention Assemblies
LIST OF DOUBLE CHECK VALVE ASSEMBLIES

The following is a partial list of **Double Check Valve Assemblies** (DCVA) approved for use to protect a potable water supply. These assemblies are limited to only **Low Hazard or Non-Health Hazard** category backflow protection. Low Hazard or Non- Health Hazard shall mean an actual or potential threat to the physical properties of the public or consumers' water system but not a danger to health. The greatest degradation of the public water supply would be of a nuisance or aesthetically objectionable nature.

COMPANY	MODEL	SIZES
AMES	2000B	½” – 2”
AMES	C200 and C200N	2 ½”-10”
AMES	M200 and M200N	2 ½”10”
APOLLO / CONBRACO	DC4A	½” – 12”
APOLLO / CONBRACO	DC4An	2½” – 12”
APOLLO / CONBRACO	DC4SG	2 ½” –10”
FEBCO	850	½”-10”
FEBCO	850U	½”-2”
FEBCO	870V	2 ½”-8”
WATTS	007	½” - 3”
WATTS	719	½” – 2”
WATTS	757 and 757N	2 ½”-10”
WATTS	709	2½” – 10”
WILKINS	350	¾” - 12”
WILKINS	350A,350AST & 450	2½” – 10”
WILKINS	950XLT2	¾” – 2”

NOTE: This is a partial list of approved DCVA assemblies. Some models are also available in “N” or “Z” configurations. Other models may have previous approvals and may still be available from suppliers. Other models may have gained recent approval. Please call to check on approval of a specific model not listed.

REVISION, November 2016

Appendix A-2.1

Approved Backflow Prevention Assemblies
LIST OF REDUCED PRESSURE PRINCIPLE ASSEMBLIES

The following is a list of **Reduced Pressure Principle Assemblies (RP)** for use to protect the potable water supply. These assemblies shall be used for **High Hazard or Health Hazard** category cross connection control. High Hazard or Health Hazard category shall mean an actual or potential danger to a potable water system of a toxic nature or danger to health.

COMPANY	MODEL	SIZE
AMES	4000B	½"-2"
AMES	C400 , C400N & C400Z	2 ½"-10"
AMES	M400 , M400N & M400Z	2 ½"-10"
APOLLO / CONBRACO	RP4A	½"-12"
APOLLO / CONBRACO	RP4An	2½" – 12"
FEBCO	825Y and 825YA	¾"-2"
FEBCO	860	½" – 10"
FEBCO	860U	½" – 2"
FEBCO	880V	2 ½"-10"
WATTS	009	¼"-3"
WATTS	909	¾"-10
WATTS	919	¼"-2"
WATTS	957, 957N & 957Z	2 ½"-10"
WILKINS	375	½" – 10"
WILKINS	975XL	¼"-2"
WILKINS	375A, 375AST, 475, 475V	2 ½"-10"

NOTE: This is a partial list of approved RP assemblies. Other models may have previous approvals and may still be available from suppliers. Other models may have gained recent approval. Please call to check on approval of a specific model not listed.

RP assemblies are not approved for vertical installations. Some models come in "N" or "Z" configurations that allow vertical piping.

RP assemblies can not be installed where the relief valve may become submerged.

REVISION, November 2016

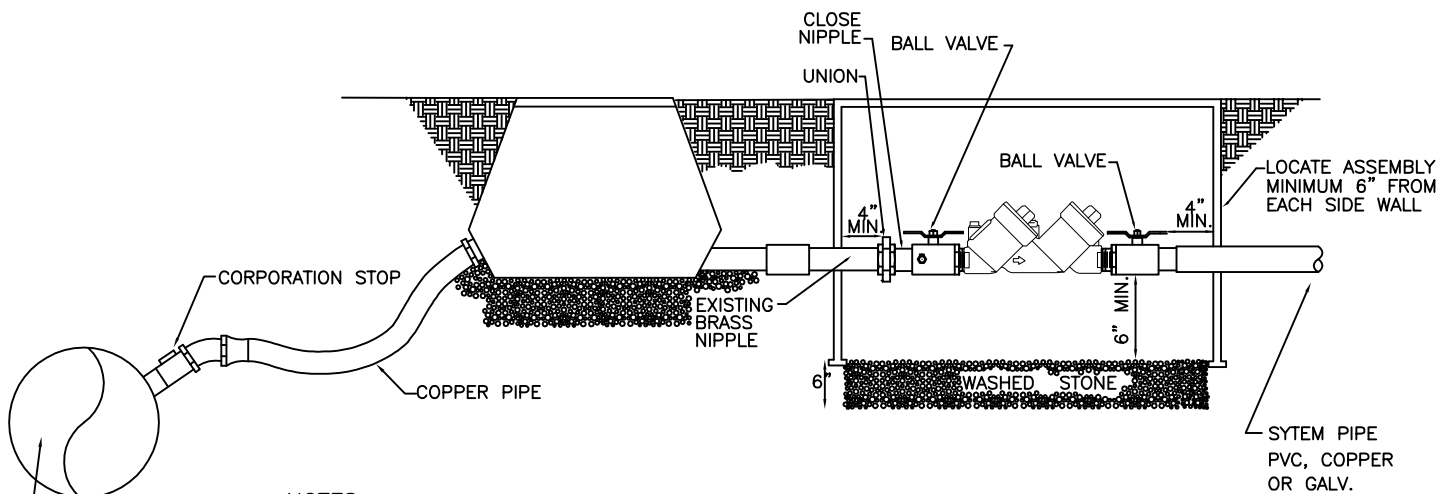
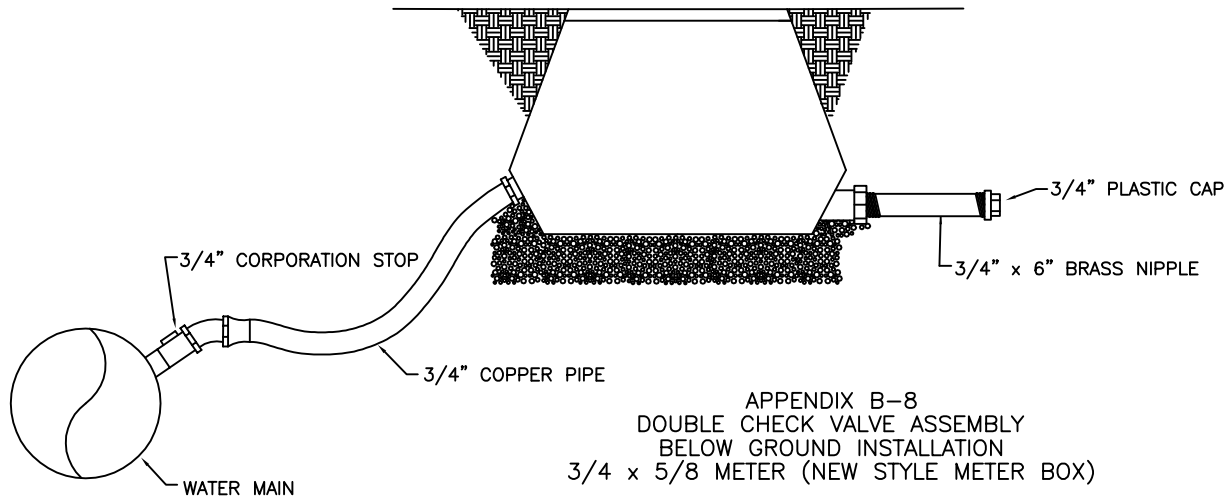

NOTES:

- 1) REMOVE 3/4" PLASTIC CAP.
- 2) INSTALL UNION CLOSE NIPPLE AND BACKFLOW ASSEMBLY DIRECTLY TO EXISTING 3/4" x 6" BRASS NIPPLE.
- 3) BOX SHALL BE CONSTRUCTED AT OWNERS DISCRETION OF SUITABLE MATERIAL WITH REMOVABLE ACCESS COVER CAPABLE OF HANDLING TRAFFIC LOAD THAT IT MAY BE SUBJECT. ALSO IT SHALL BE VANDAL RESISTANT AND PROVIDE PROTECTION FROM WEATHER ELEMENTS.

CROSS CONNECTION
CONTROL MANUAL

DOUBLE CHECK VALVE ASSEMBLY
COMMERCIAL APPLICATION
3/4" x 5/8" METER BOX

FILE NO. APPENDIX B-8
DATE: DECEMBER 22, 2008



ENGINEERING DEPARTMENT

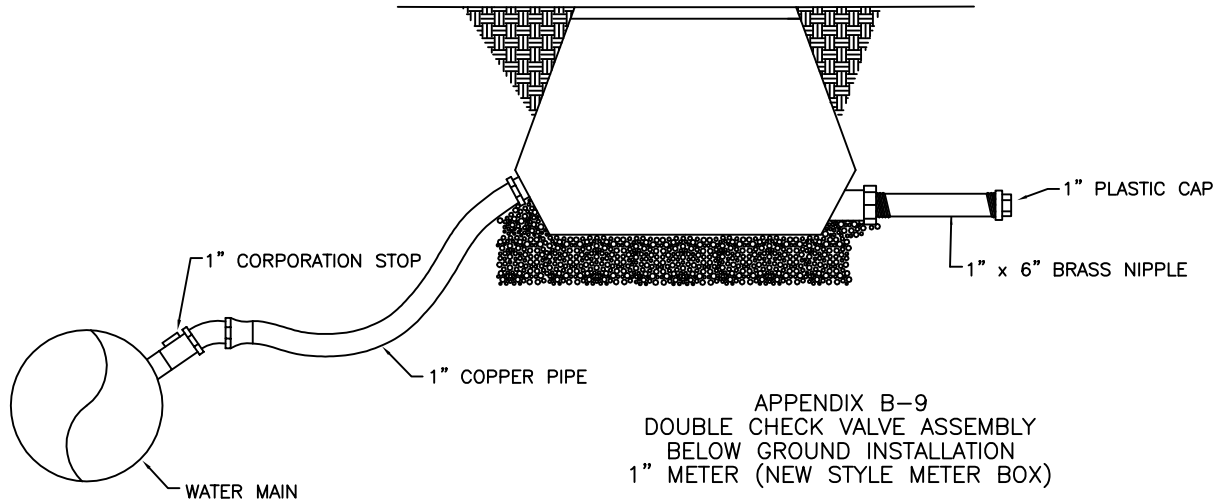

APPENDIX B-9
 DOUBLE CHECK VALVE ASSEMBLY
 BELOW GROUND INSTALLATION
 1" METER (NEW STYLE METER BOX)
STANDARD INSTALLATION

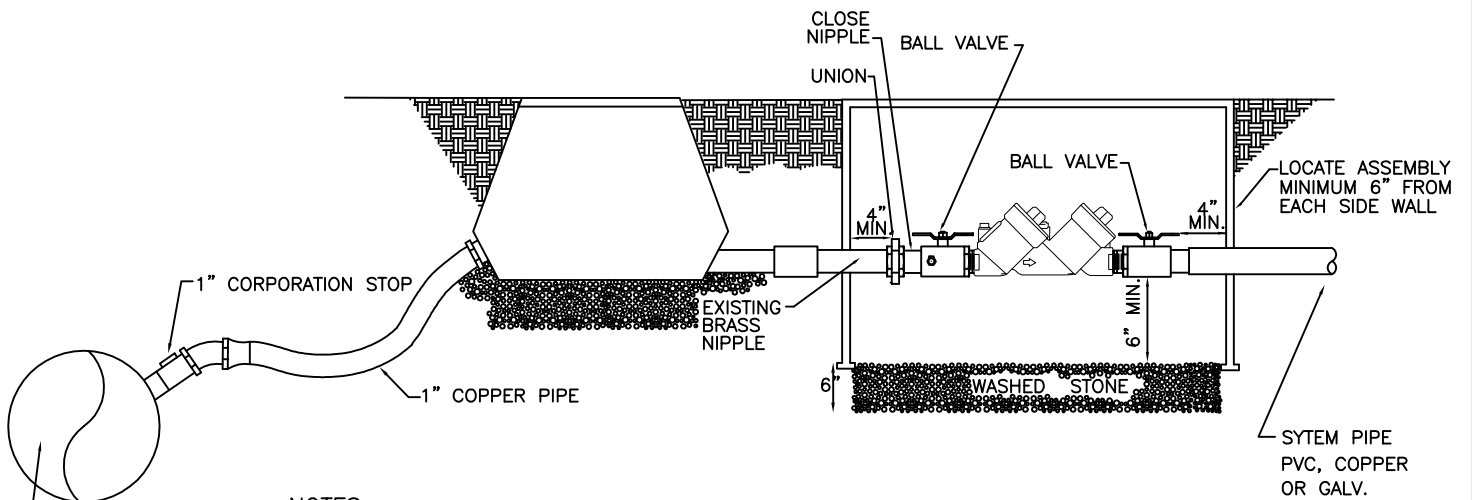

NOTES:

- 1) REMOVE 1" PLASTIC CAP.
- 2) INSTALL UNION CLOSE NIPPLE AND BACKFLOW ASSEMBLY DIRECTLY TO EXISTING 1" x 6" BRASS NIPPLE.
- 3) BOX SHALL BE CONSTRUCTED AT OWNERS DISCRETION OF SUITABLE MATERIAL WITH REMOVABLE ACCESS COVER CAPABLE OF HANDLING TRAFFIC LOAD THAT IT MAY BE SUBJECT. ALSO IT SHALL BE VANDAL RESISTANT AND PROVIDE PROTECTION FROM WEATHER ELEMENTS.

CROSS CONNECTION CONTROL MANUAL		
DOUBLE CHECK VALVE ASSEMBLY COMMERCIAL APPLICATION 1" METER BOX		
FILE NO.	APPENDIX B-9	
DATE:	DECEMBER 22, 2008	ENGINEERING DEPARTMENT

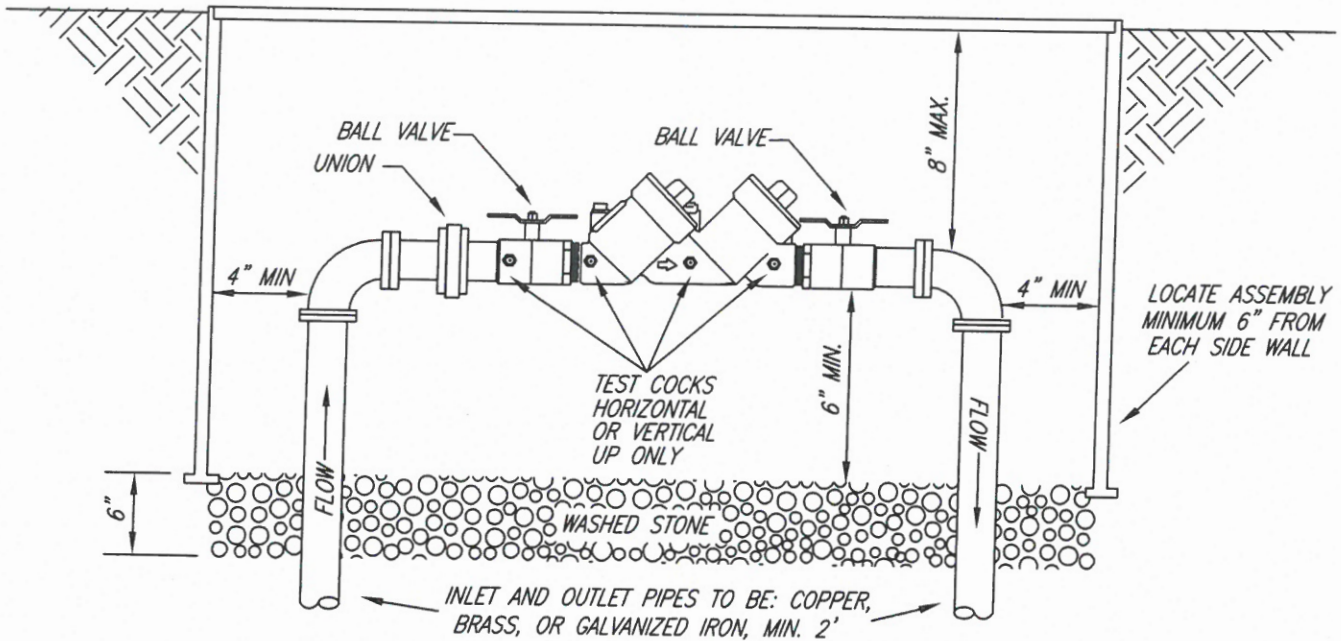

NOTES:

BOX SHALL BE CONSTRUCTED AT OWNER'S DISCRETION OF SUITABLE MATERIAL WITH REMOVABLE ACCESS COVER CAPABLE OF HANDLING TRAFFIC LOAD THAT IT MAY BE SUBJECTED TO. ALSO, IT SHALL BE VANDAL RESISTANT AND PROVIDE PROTECTION FROM WEATHER ELEMENTS.

CROSS CONNECTION CONTROL MANUAL	
DOUBLE CHECK VALVE ASSEMBLY	
BELOW GROUND INSTALLATION	
1-1/2" & 2"	
FILE NO.	APPENDIX B-1
DATE:	DECEMBER 22, 2008



ENGINEERING DEPARTMENT

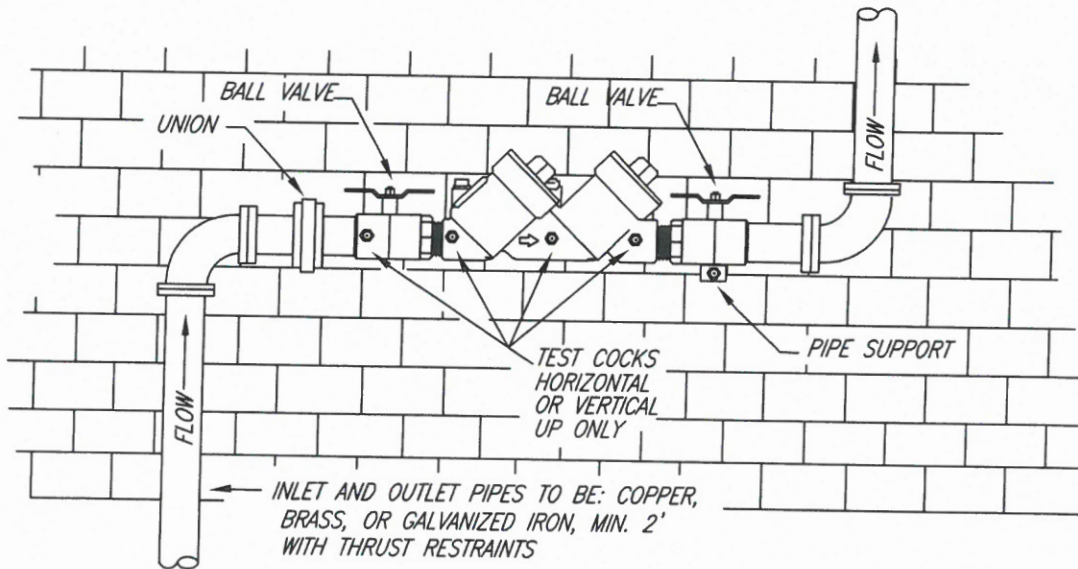

NOTES:

ASSEMBLY TO BE MINIMUM OF 6" FROM WALL AND 12" (MIN.) TO 48" (MAX.) OFF FLOOR.

CROSS CONNECTION CONTROL MANUAL	
DOUBLE CHECK VALVE ASSEMBLY	
INSIDE BUILDING	
2" AND SMALLER	
FILE NO.	APPENDIX B-2
DATE:	DECEMBER 22, 2008



ENGINEERING DEPARTMENT

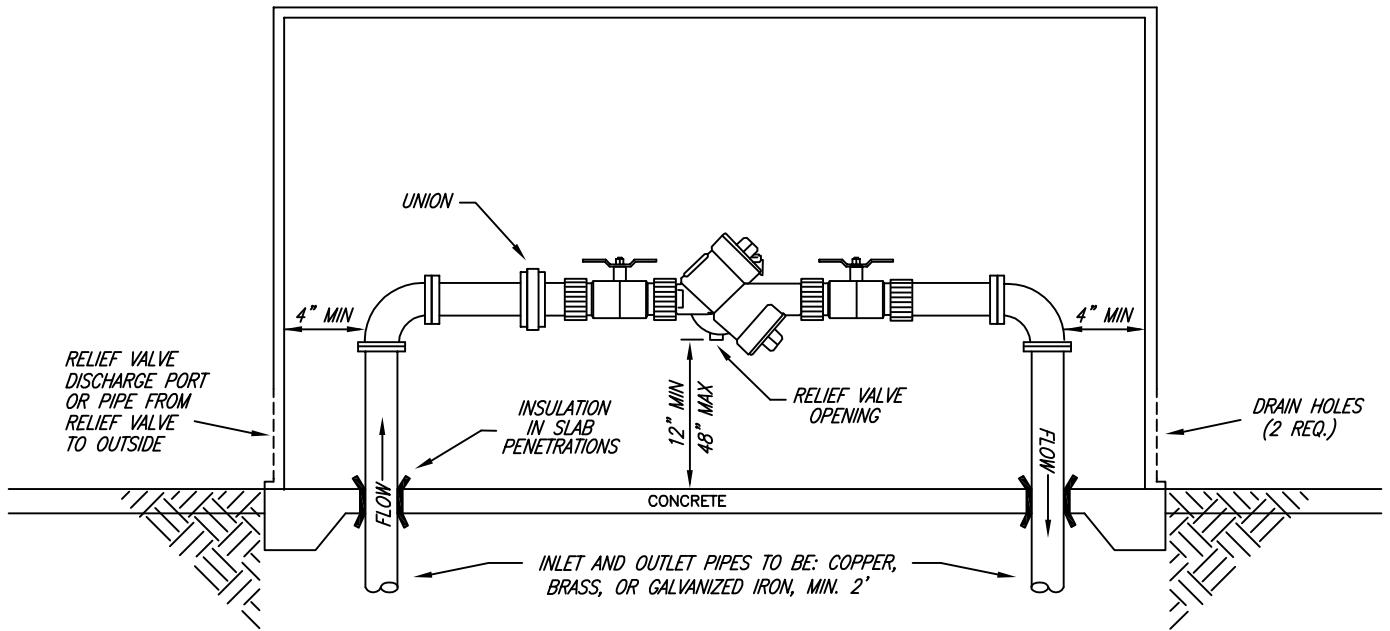

NOTES:

1. ENCLOSURE TO BE ENGINEERED BACKFLOW PREVENTION ASSEMBLY OUTSIDE ENCLOSURE OR CONSTRUCTED TO PREVENT FREEZE AND VANDALISM.
2. PROVIDE HEAT WHERE NECESSARY.

CROSS CONNECTION CONTROL MANUAL	
REDUCED PRESSURE ASSEMBLY ABOVE GROUND ENCLOSURE 2" AND SMALLER	
FILE NO.	APPENDIX B-4
DATE:	DECEMBER 22, 2008



ENGINEERING DEPARTMENT

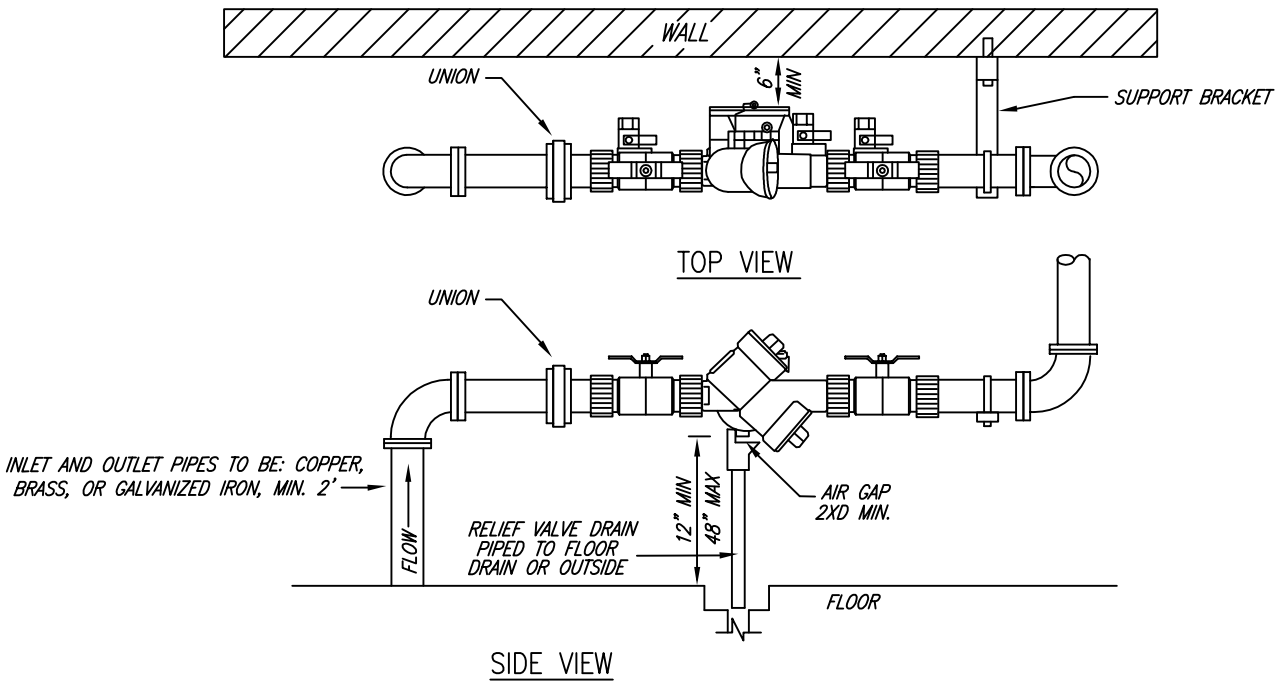

CROSS CONNECTION CONTROL MANUAL	
REDUCED PRESSURE ASSEMBLY INSIDE BUILDING 2" AND SMALLER	
FILE NO.	APPENDIX B-5
DATE:	DECEMBER 22, 2008



ENGINEERING DEPARTMENT

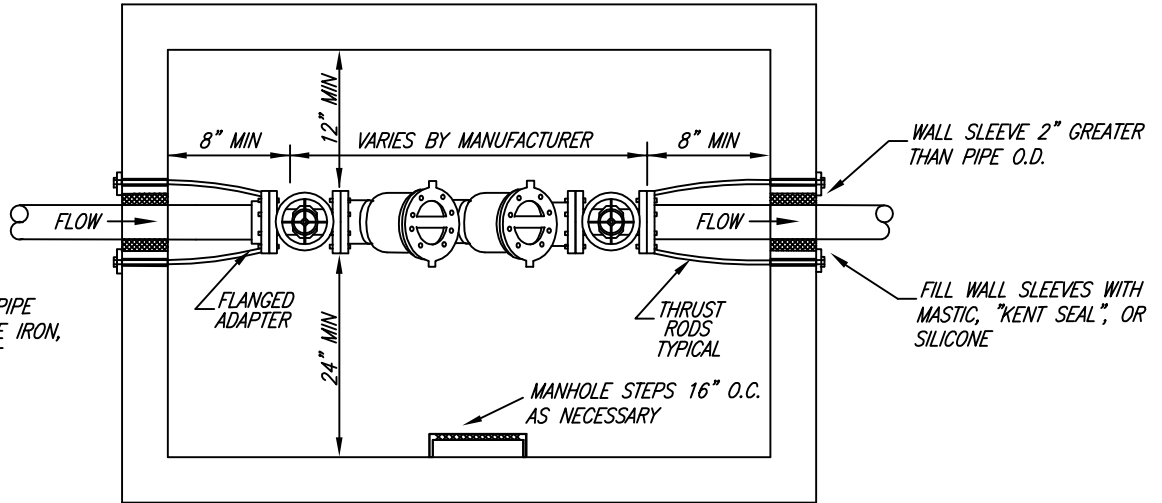

NOTE: INLET AND OUTLET PIPE TO BE COPPER OR DUCTILE IRON, MINIMUM 2' WITH ADEQUATE THRUST RESTRAINTS

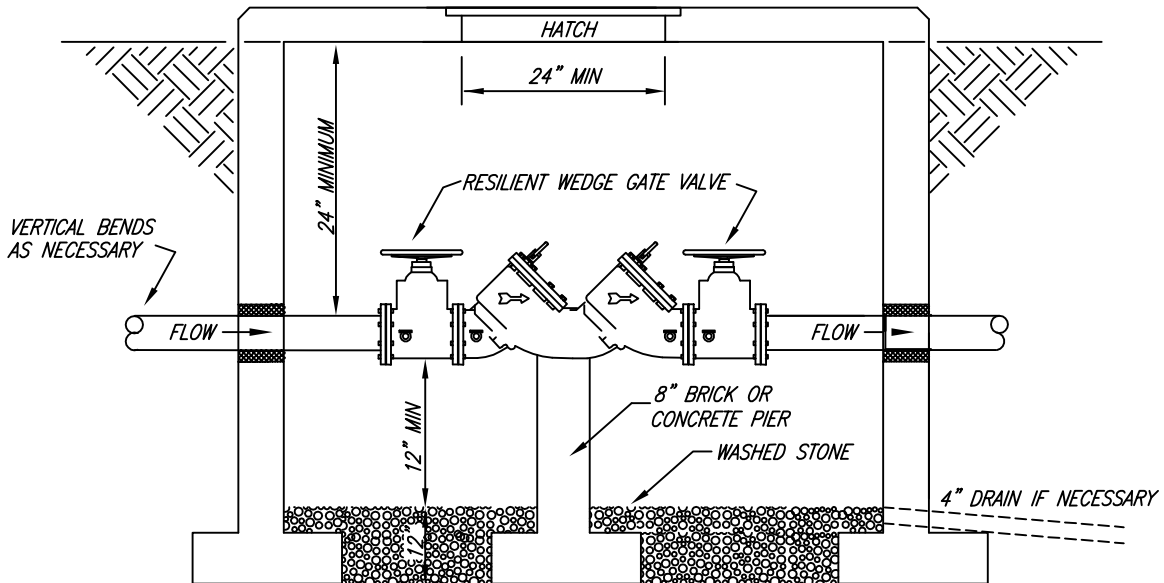

NOTES:

- WALLS MAY BE PRECAST CONCRETE, REINFORCED POURED IN PLACE CONCRETE, FILLED BLOCK, OR BRICK.
- TOP MAY BE REINFORCED CONCRETE, REINFORCED POURED IN PLACE CONCRETE, STEEL PLATE WITH EPOXY COATING, OR ALUMINUM PLATE.
- HATCH SHALL BE MANUFACTURED STEEL OR ALUMINUM DOOR, CAST IRON MANHOLE RING AND EQUAL TO SUMTER MACHINE MF-11 FRAME AND MF-18 COVER, OR FABRICATED STEEL OR ALUMINUM OPENING SUITABLE TO OWNER.
- WALL SLEEVES P.V.C., CAST IRON, STEEL, OR CORE DRILLED CONCRETE.

CROSS CONNECTION CONTROL MANUAL	
DOUBLE CHECK VALVE ASSEMBLY UNDERGROUND INSTALLATION LARGER THAN 2"	
FILE NO.	APPENDIX B-3
DATE:	DECEMBER 22, 2008



ENGINEERING DEPARTMENT

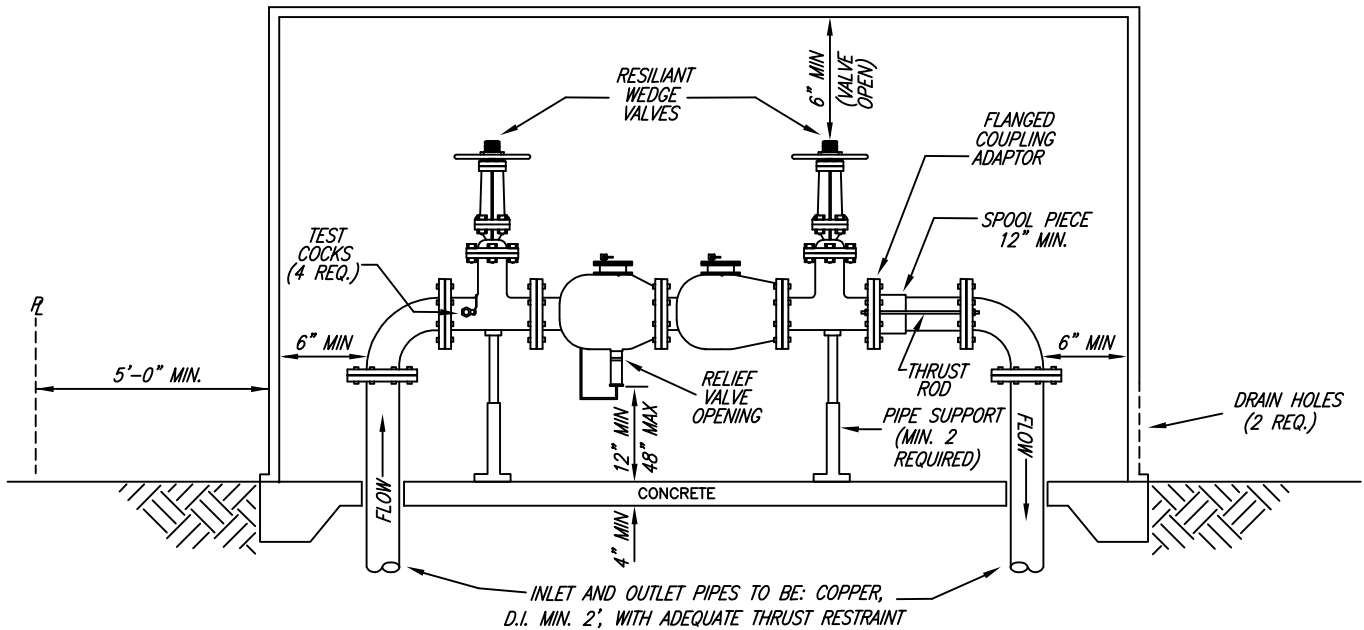

NOTES:

1. INSULATE OR PROVIDE HEAT TO PREVENT FREEZING.
2. MINIMUM 12" CLEARANCE EACH SIDE OF ASSEMBLY
3. 2) DRAIN HOLES ABOVE GROUND EQUAL TO DIA. OF RELIEF VALVE

CROSS CONNECTION CONTROL MANUAL

REDUCED PRESSURE PRINCIPLE ASSEMBLY ~ ABOVE GROUND ENCLOSURE LARGER THAN 2"
(ENCLOSURE CAN ALSO BE USED FOR DOUBLE CHECK VALVE ASSEMBLY)

FILE NO. APPENDIX B-6
 DATE: DECEMBER 22, 2008



ENGINEERING DEPARTMENT

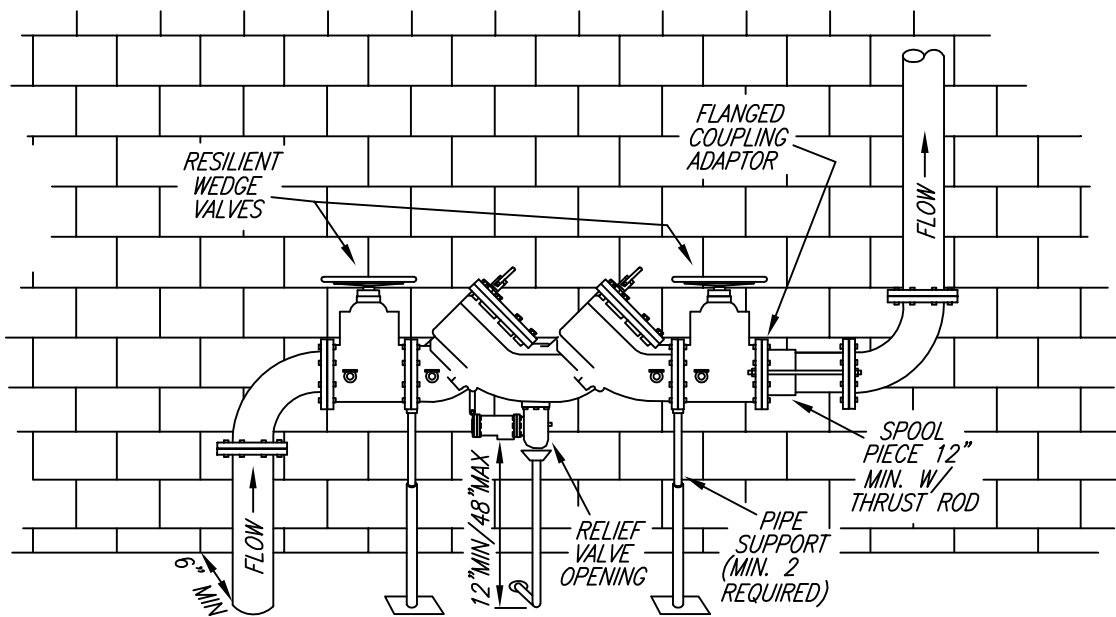

INLET AND OUTLET PIPE TO BE COPPER, DUCTILE IRON. MINIMUM 2' WITH ADEQUATE THRUST RESTRAINTS.

CROSS CONNECTION CONTROL MANUAL

REDUCED PRESSURE ASSEMBLY OR DOUBLE CHECK VALVE ASSEMBLY INSIDE BUILDING ~ LARGER THAN 2"

FILE NO. APPENDIX B-7
 DATE: DECEMBER 22, 2008



ENGINEERING DEPARTMENT

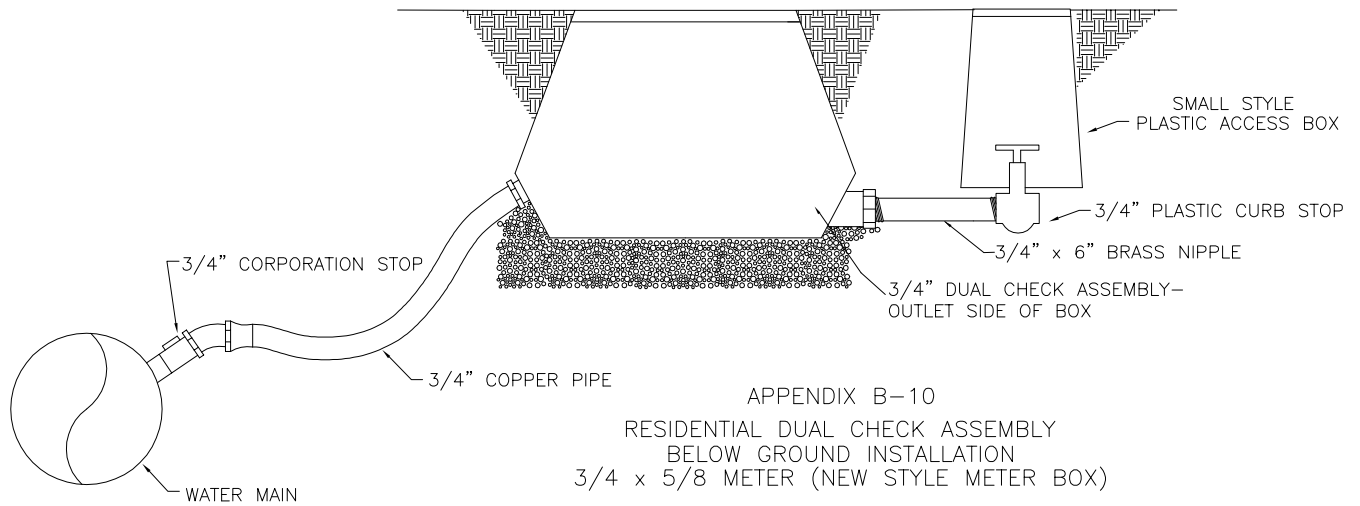

APPENDIX B-10
 RESIDENTIAL DUAL CHECK ASSEMBLY
 BELOW GROUND INSTALLATION
 3/4 x 5/8 METER (NEW STYLE METER BOX)
STANDARD INSTALLATION

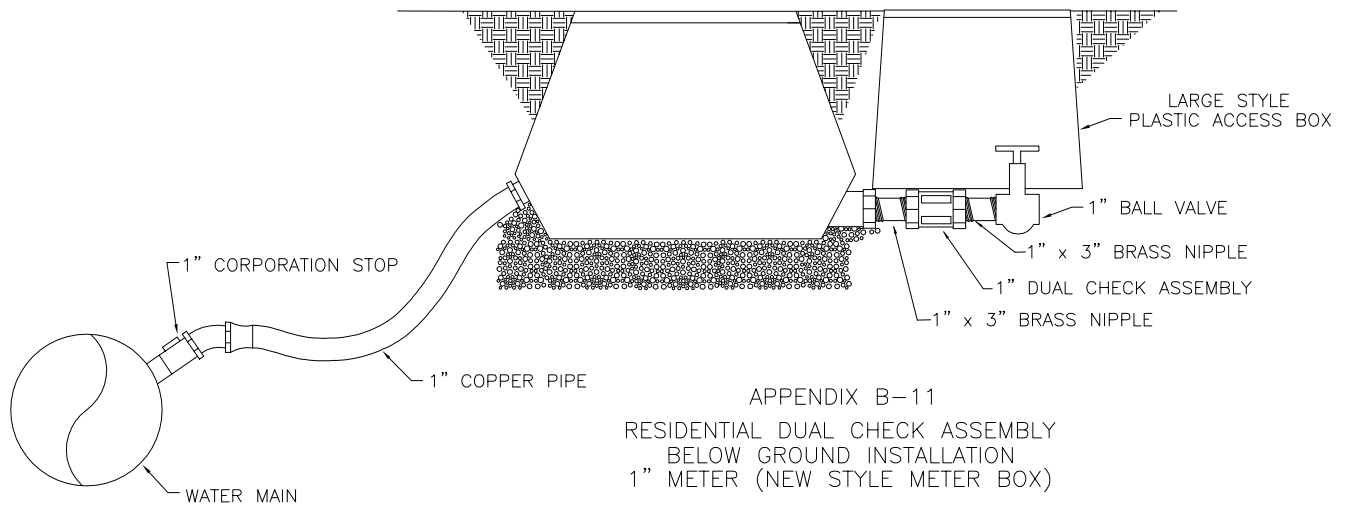

APPENDIX B-11
 RESIDENTIAL DUAL CHECK ASSEMBLY
 BELOW GROUND INSTALLATION
 1" METER (NEW STYLE METER BOX)
STANDARD INSTALLATION

CROSS CONNECTION
 CONTROL MANUAL

DUAL CHECK ASSEMBLY
 RESIDENTIAL APPLICATION
 3/4" x 5/8" & 1" METER BOXES

FILE NO. APPENDIX B-10 & B-11
 DATE: DECEMBER 22, 2008



ENGINEERING DEPARTMENT

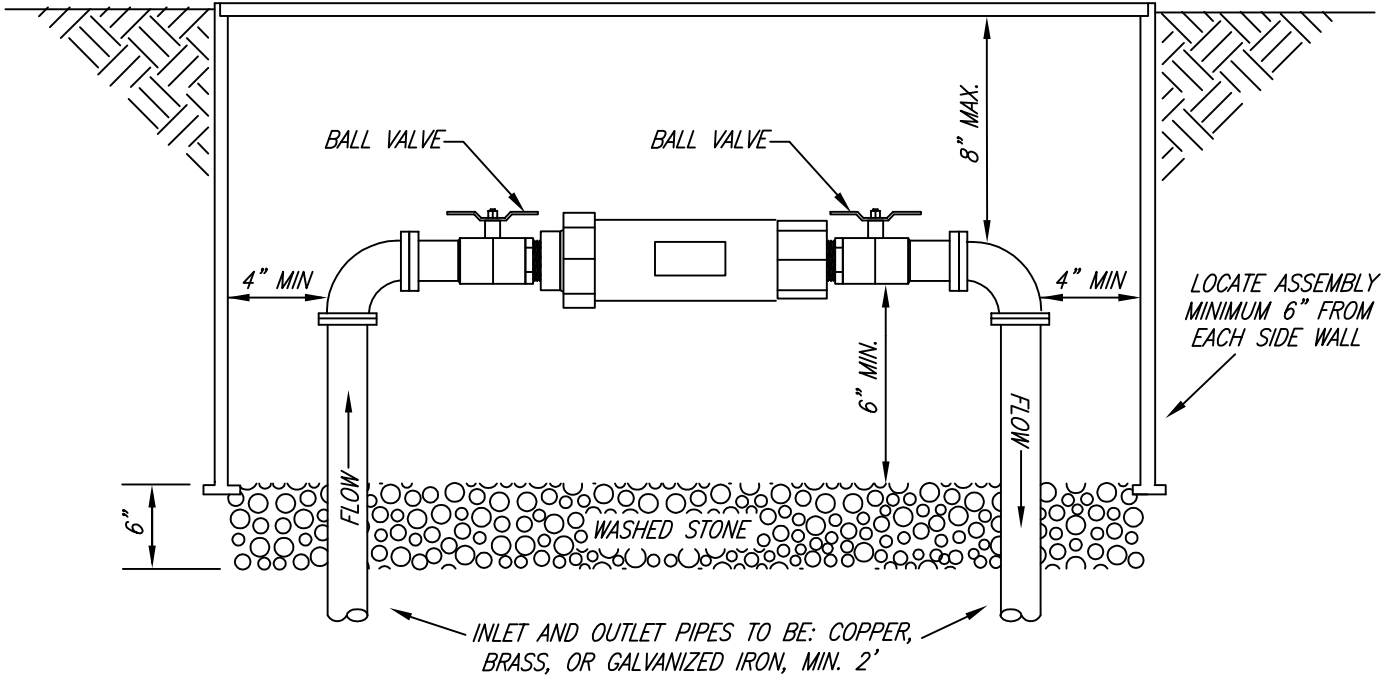

NOTES:
 BOX SHALL BE CONSTRUCTED AT OWNER'S DISCRETION OF SUITABLE MATERIAL WITH REMOVABLE ACCESS COVER CAPABLE OF HANDLING TRAFFIC LOAD THAT IT MAY BE SUBJECTED TO. ALSO, IT SHALL BE VANDAL RESISTANT AND PROVIDE PROTECTION FROM WEATHER ELEMENTS.

CROSS CONNECTION CONTROL MANUAL		
DUAL CHECK ASSEMBLY RESIDENTIAL ALTERNATIVE INSTALLATION 3/4" & 1" METER BOXES		
FILE NO.	APPENDIX B-12	
DATE:	DECEMBER 22, 2008	ENGINEERING DEPARTMENT

CCC Compliance Testing Flowchart

14 Days

+

14 Days

+

14 Days

= 42 Days

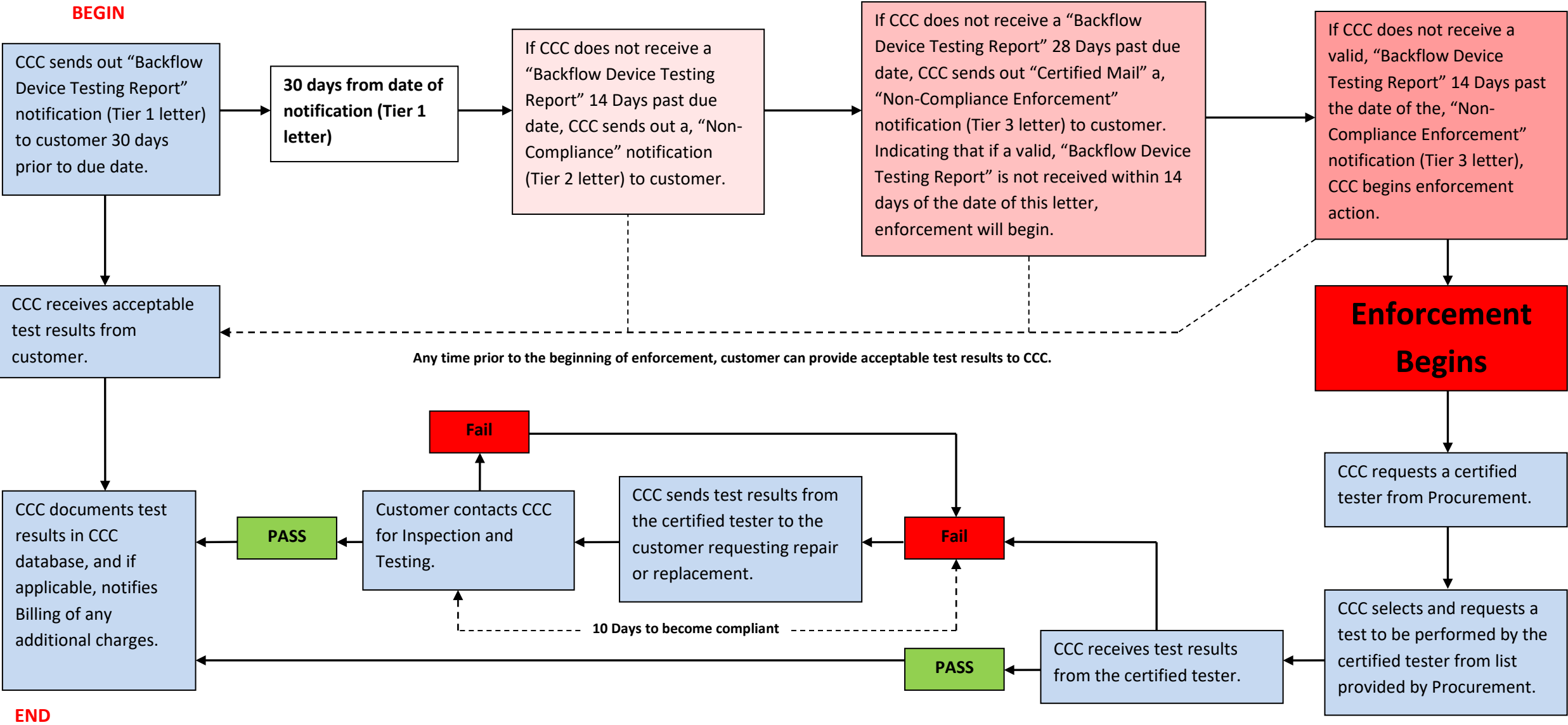

New Single Family Residential ¾" and 1" Meters Cross Connection Control Process Flow Chart

BEGIN

Customer applies for a water service connection at "New Connections".

New Connections executes a "Water Service Agreement" with customer. New Connections and customer completes a service questionnaire. New Connections generates a, "Tap Sheet". New Connections forwards the, Tap Sheet to C&D, then forwards a copy of the, "Tap Sheet", and service Questionnaire to CCC.

CCC receives the Tap Sheet and service questionnaire. CCC performs hazard evaluation from the service questionnaire and determines the level of backflow Hazard.

C&D completes service tap per Tap Sheet directions.

If hazard is discovered, CCC notifies C&D to lock meter after installation, and sends a letter to the customer, notifying them to contact CCC for an inspection.

Prior to contact from the customer, CCC Tech. visits location frequently to confirm meter remains locked and ensure status of service has not changed.

If NO hazard is discovered, CCC Takes no further action.

CCC receives a request for inspection from the customer.

Customer Activity

New Connections Activity

CCC Activity

C&D Activity

Customer contacts CCC for re-inspection. CCC performs re-inspection.

CCC provides required corrections needed to customer requesting them to contact CCC when corrections have been made to schedule a re-inspection.

Inspection is NOT good.

CCC performs the inspection.

Inspection is good.

END

CCC completes the backflow device test form, and documents results in backflow account tracking database, and creates customer account file.

CCC performs a test on the backflow device.

CCC places the meter in service.

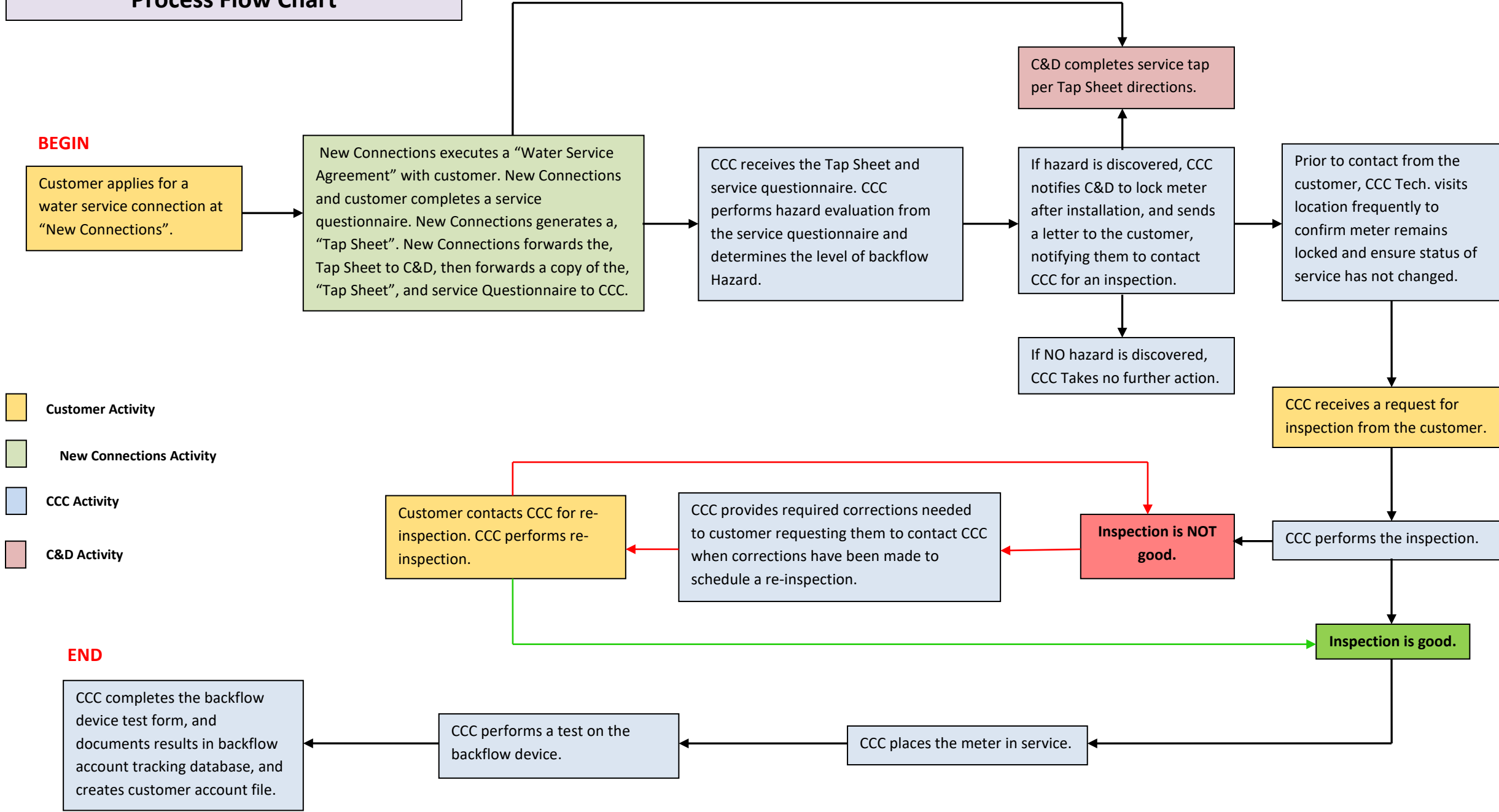

New Single Family Residential 1 ½ and 2” Meters Cross Connection Control Process Flow Chart

BEGIN

Customer applies for a water service connection at “New Connections”.

New Connections executes a “Water Service Agreement” with customer. New Connections and customer completes a, “CCC questionnaire”. New Connections generates a, “Tap Sheet” with instructions to lock meter. New Connections forwards the, Tap Sheet to C&D, and then forwards a copy of the, “Tap Sheet”, and the “CCC Questionnaire” to CCC.

C&D completes service tap per Tap Sheet directions.

CCC receives the Tap Sheet and, “CCC questionnaire”. CCC performs hazard evaluation from the, “CCC questionnaire”, and determines the level of backflow Hazard.

CCC sends a “CCC Compliance” letter including enclosures outlining requirements to the customer, requesting them to contact CCC for an inspection after installation.

Prior to contact from the customer, CCC Tech. visits location frequently to confirm meter remains locked and ensure status of service has not changed.

CCC receives a request for inspection from the customer.

CCC performs the inspection.

Inspection is NOT good.

CCC provides required corrections needed to customer requesting them to contact CCC when corrections have been made to schedule a re-inspection.

Customer contacts CCC for re-inspection. CCC performs re-inspection.

Inspection is good.

CCC performs a test on the backflow device.

Test is NOT good.

CCC provides required corrections needed to customer requesting them to contact CCC when corrections have been made to schedule a re-test.

Customer contacts CCC for re-test. CCC performs re-test.

Test is good.

CCC Completes the backflow device test form, and places the meter in service.

CCC documents results in backflow account tracking database, and creates customer account file.

END

- Customer Activity
- New Connections Activity
- CCC Activity
- C&D Activity

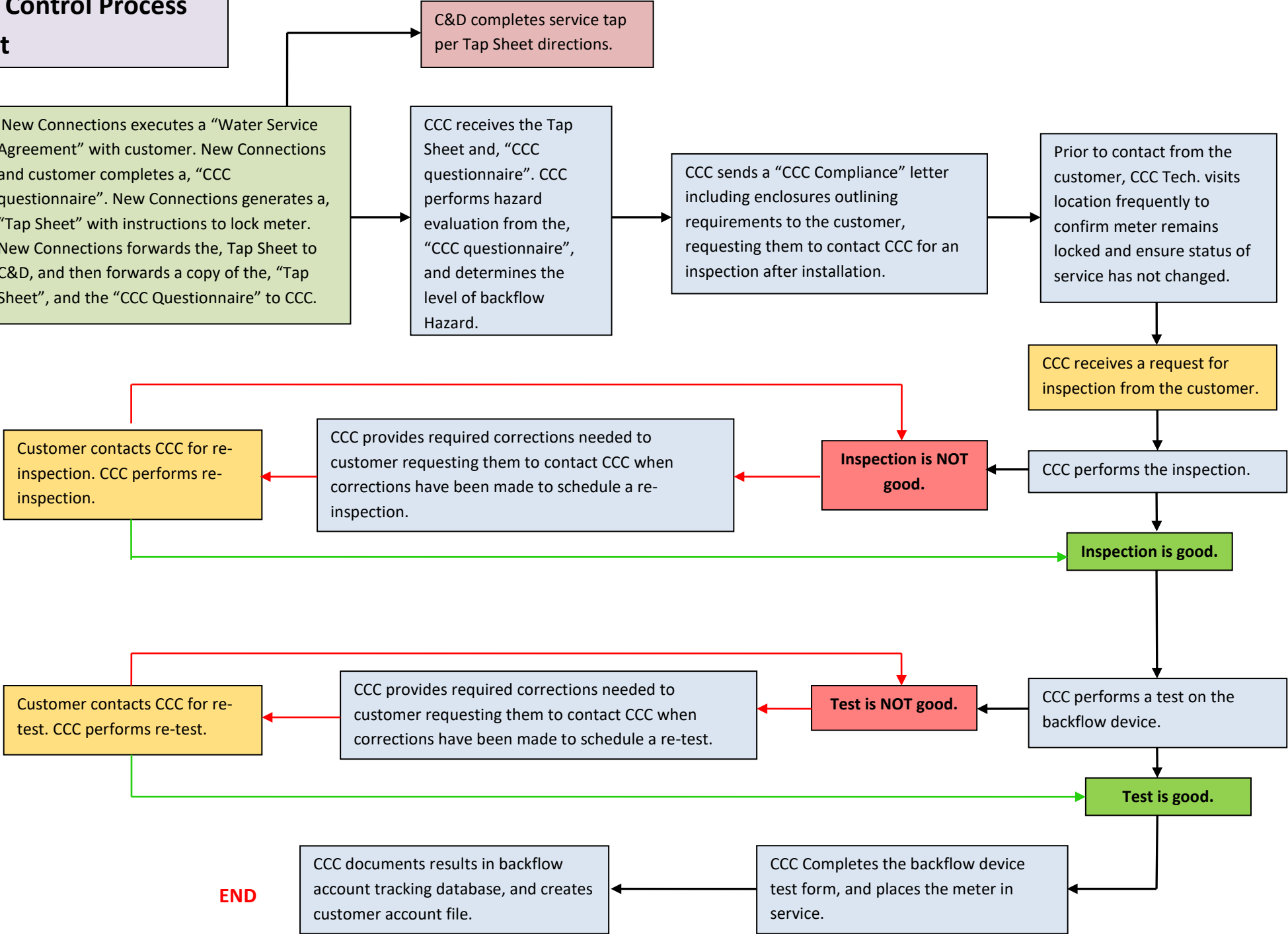

Large Meters 3" and Larger and, Fire Services Cross Connection Control Process Flow Chart

BEGIN

