

***TECHNICAL
SPECIFICATIONS
FOR
SANITARY SEWER
SYSTEM IMPROVEMENTS***



SPARTANBURG SANITARY SEWER DISTRICT

SPARTANBURG, SOUTH CAROLINA

June 2009

TABLE OF CONTENTS

	<u>PAGE</u>
<u>SECTION 1 GENERAL PROVISIONS</u>	
1-01 INTENT AND SCOPE OF PLANS AND SPECIFICATIONS	1-1
1-02 MATERIALS AND WORKMANSHIP	1-2
1-03 SOURCE OF SUPPLY AND QUALITY OF MATERIALS.....	1-3
1-04 SAMPLES AND TESTING OF MATERIALS.....	1-3
1-05 PRECONSTRUCTION CONFERENCE	1-3
1-06 INSPECTION	1-4
1-07 VERIFICATION OF DIMENSIONS AND ELEVATIONS	1-5
1-08 CARE OF EXISTING FACILITIES.....	1-5
1-09 CONNECTION TO EXISTING WORK	1-6
1-10 INSURANCE	1-6
 <u>SECTION 2 RIGHTS-OF-WAY AND EASEMENTS</u>	
2-01 SCOPE.....	2-1
2-02 WORK ON RIGHTS-OF-WAY AND EASEMENTS.....	2-1
2-03 WORK ON STATE AND COUNTY HIGHWAYS OR ROADS, TOWN OR CITY ROADS OR STREETS, RAILROAD AND OTHER UTILITY RIGHTS-OF-WAY.....	2-3
2-04 RESTORATION OF RIGHTS-OF-WAY:.....	2-4
 <u>SECTION 3 MANHOLES</u>	
3-01 SCOPE.....	3-1
3-02 DESIGN CRITERIA	3-1
3-03 MATERIALS	3-1
3-04 INSTALLATION	3-4
 <u>SECTION 4 GRAVITY SEWER: MATERIALS AND GENERAL INSTALLATION</u>	
4-01 SCOPE.....	4-1
4-02 DESIGN CRITERIA	4-1
4-03 MATERIALS	4-2
4-04 GENERAL GRAVITY SEWER PIPELINE INSTALLATION	4-4
 <u>SECTION 5 SEWER FORCE MAIN: MATERIALS AND GENERAL INSTALLATION</u>	
5-01 SCOPE.....	5-1
5-02 DESIGN CRITERIA	5-1
5-03 MATERIALS	5-3
5-04 GENERAL SEWER FORCE MAIN INSTALLATION.....	5-10

	<u>PAGE</u>
<u>SECTION 6 TRENCH EXCAVATION AND BACKFILL</u>	
6-01 SCOPE.....	6-1
6-02 GENERAL.....	6-1
6-03 TRENCH EXCAVATION.....	6-2
6-04 CLASSIFICATION OF EXCAVATION.....	6-3
6-05 BEDDING OF PIPE.....	6-4
6-06 BACKFILLING OF TRENCHES.....	6-5
 <u>SECTION 7 SEWER SERVICE CONNECTIONS</u>	
7-01 SCOPE.....	7-1
7-02 DESIGN CRITERIA.....	7-1
7-03 GENERAL MATERIALS.....	7-1
7-04 INSTALLATION OF SERVICE LINES ON NEW SEWER PROJECTS.....	7-1
7-05 SERVICE CONNECTIONS TO EXISTING LINES.....	7-2
 <u>SECTION 8 BORING AND AERIAL CROSSINGS</u>	
8-01 SCOPE.....	8-1
8-02 BORING (INCLUDING JACK AND BORE, IMPACT MOLE, CLOSED-FACE BORE, MICRO-TUNNELING AND OTHERS).....	8-1
8-03 HORIZONTAL DIRECTIONAL DRILLING (HDD).....	8-6
8-04 PIPE SUPPORTED ON PIERS.....	8-9
8-05 PIPE ATTACHED TO BRIDGES.....	8-10
 <u>SECTION 9 PAVEMENT AND SURFACING</u>	
9-01 SCOPE.....	9-1
9-02 DESIGN CRITERIA.....	9-1
9-03 CUTTING AND REPLACING PAVEMENT.....	9-1
9-04 REMOVING AND REPLACING SIDEWALK.....	9-2
 <u>SECTION 10 GRASSING AND EROSION CONTROL</u>	
10-01 SCOPE.....	10-1
10-02 MATERIALS.....	10-1
10-03 INSTALLATION OF GRASS AND RELATED MATERIALS.....	10-5
10-04 TURF MAINTENANCE.....	10-9
10-05 EROSION CONTROL MEASURES.....	10-10

SECTION 11 SEWER PUMP STATIONS

11-01 SCOPE..... 11-1
11-02 DESIGN CRITERIA 11-1
11-03 SUBMITTALS 11-4
11-04 MATERIALS AND EQUIPMENT..... 11-5
11-05 INSTALLATION 11-22
11-06 PUMP STATION FENCING 11-23
11-07 QUALITY ASSURANCE AND CERTIFICATION 11-25

SECTION 12 INSPECTION AND TESTING

12-01 SCOPE..... 12-1
12-02 GRAVITY SEWER LINE TESTING..... 12-1
12-03 MANHOLE TESTING..... 12-5
12-04 FORCE MAIN TESTING 12-6
12-05 CCTV INSPECTION 12-7

SECTION 13 GREASE, OIL, and SAND TRAPS or INTERCEPTORS

13-01 SCOPE..... 13-1
13-02 GENERAL PROVISIONS 13-1
13-03 MATERIALS 13-3
13-04 INSTALLATION 13-4

SECTION 14 WORK INVOLVING EXISTING FACILITES

14-01 GENERAL 14-1
14-02 VEHICLE ACCESS 14-1
14-03 BY-PASS PUMPING 14-1

SECTION 15 REHABILITATION AND PROTECTION OF CONCRETE AND BRICK
MANHOLES OR UNDERGROUND VAULTS

15-01 SCOPE..... 15-1
15-02 DESIGN CRITERIA 15-1
15-03 SUBMITTALS 15-1
15-04 PRODUCTS AND MATERIALS 15-3
15-05 PROTECTIVE COATING APPLICATION EQUIPMENT..... 15-7
15-06 EXECUTION..... 15-7
15-07 TESTING AND INSPECTION 15-11

SECTION 16 REHABILITATION OF SANITARY SEWER MAINS BY PIPE BURSTING

16-01 GENERAL 16-1
16-02 SCOPE..... 16-1
16-03 REFERENCE STANDARDS 16-2
16-04 QUALIFICATIONS OF THE CONTRACTOR AND QUALITY ASSURANCE.. 16-3
16-05 SUBMITTALS 16-4
16-06 DELIVERY, STORAGE AND HANDLING OF PIPE AND MATERIALS..... 16-5
16-07 APPROVED METHODS OF PIPE BURSTING 16-6
16-08 PIPE MATERIALS 16-6
16-09 EXECUTION..... 16-7
16-10 TESTING..... 16-10
16-11 WARRANTY 16-11

SECTION 17 REHABILITATION OF SANITARY SEWER MAINS USING CURED-IN-PLACE PIPE

17-01 GENERAL 17-1
17-02 SCOPE..... 17-1
17-03 DESIGN CRITERIA 17-3
17-04 PRODUCTS..... 17-4
17-05 SUBMITTALS 17-5
17-06 EXECUTION..... 17-8
17-07 FINAL INSPECTION AND REPORTS 17-13
17-08 WARRANTY 17-13

SECTION 18 WARRANTY

18-01 WARRANTY FOR ONE YEAR AFTER COMPLETION 18-1
18-02 MAINTENANCE 18-1

APPENDIX A

STANDARD CONSTRUCTION DETAILS

- NO. 1 STANDARD PRECAST MANHOLE
- NO. 2 STANDARD PRECASE MANHOLE JOINT DETAIL
- NO. 3 PLAN OF MANHOLE INVERTS
- NO. 4 STANDARD MANHOLE FRAME AND COVER
- NO. 5 MANHOLE ENTRANCE “BOOT”
- NO. 6 TYPICAL OUTSIDE DROP MANHOLE
- NO. 7 TYPICAL INSIDE DROP MANHOLE
- NO. 8 PRECAST MANHOLE (DOGHOUSE) OVER EXISTING SEWER
- NO. 9 TYPICAL CONCRETE COLLAR DETAIL
- NO. 10 DIP TO HDPE TRANSISTION
- NO. 11 TYPICAL TRENCHING DETAIL
- NO. 12 IMPROVED DITCH BEDDING DETAIL
- NO. 13 CONCRETE THRUST BLOCK DETAIL
- NO. 14 SEWER FORCE MAIN AIR / VACUUM VALVE AND MANHOLE
- NO. 15 SANITARY SEWER AND WATER LINE / STORM DRAIN CROSSING DETAIL
- NO. 16 SERVICE LINE TAP TO MANHOLE
- NO. 17 TYPICAL SEWER SERVICE CONNECTION
- NO. 18 TABLE OF SANITARY SEWER TAP LOCATIONS
- NO. 19 SERVICE LINE TAP TO EXISTING SEWER LINE
- NO. 20 CASING PIPE BORE AND JACK DETAIL
- NO. 21 CARRIER PIPE INSTALLATION IN CASING
- NO. 22 PIPE SUPPORTED ON CONCRETE PIERS

NO. 23 TYPICAL PAVEMENT REPAIR DETAILS

NO. 24 PUMP STATION VALVE VAULT WITH BYPASS CONNECTION

NO. 25 HATCH WITH FALL-PROTECTION GRATING

NO. 26 TYPICAL PUMP STATION FENCING

NO. 27 DUPLEX PUMP STATION ELECTRICAL PANEL RACK AND AWNING DETAIL

NO. 28 TWO-CHAMBER GREASE TRAP (INTERCEPTOR)

SECTION 1

GENERAL PROVISIONS

- 1-01 INTENT AND SCOPE OF PLANS AND SPECIFICATIONS: It is the intent of the plans and specifications that one shall supplement the other, but not necessarily duplicate one another. Any work called for in one and omitted in the other shall be executed as if called for in both in order that the work be fully completed according to the complete design as determined by the Consulting Engineer (Engineer) and approved by the Spartanburg Sanitary Sewer District's Project Manager. Should any discrepancy appear in or between the drawings and specifications, the specifications will govern. It is to be understood that the work described in the specifications and shown on the plans shall be complete in every detail whether every necessary item is particularly mentioned or not and the Contractor shall be held to provide all items of labor and materials necessary for the satisfactory completion of the indicated work. Any provisions contained in the specifications or shown on the standard drawings which are not applicable to the work pertaining to this project shall be disregarded. All testing shall be accomplished in accordance with these specifications and only at the discretion of the Spartanburg Sanitary Sewer District Project Manager shall any portions of the testing be waived.
- A. The Contractor shall check all dimensions, elevations, quantities and instructions shown on the plans or given in the specifications and shall notify the Engineer should any discrepancy of any kind be found in the plans, specifications or conditions at the site. He will not be allowed to take advantage of any discrepancy, error or omissions. If any discrepancy is discovered, the Engineer with Spartanburg Sanitary Sewer District's approval will issue full instructions pertaining thereto and the Contractor shall carry out these instructions as if originally specified.
- B. The Specifications are divided into Sections for convenience of reference. The materials, work, etc., mentioned or specified in one part are not intended to be limited to that part only, but shall be applied with equal force to any other part or division of work where such materials, work, equipment, etc., are mentioned or required to properly provide for acceptable work according to the true intent of the drawings and specifications. Reference to standard specifications (ASTM, AWWA, ANSI, etc.), national codes, local or state codes and laws and ordinances shall mean the latest edition of said document in effect at the time of taking bids unless specifically stated otherwise.
- C. Drawings shall be followed in construction of the work and all dimensions and elevations shown on the Plans shall be accurately maintained. Scaled measurements will not be allowed and no work shall be performed when dimensions or elevations are not indicated until such dimensions or elevations are obtained from the Engineer.

1-02 MATERIALS AND WORKMANSHIP: It is the intent of these Specifications that the Contractor shall furnish first-class materials and do all work in a first-class manner so that the completed job shall be thoroughly satisfactory in every respect. To this end, the Contractor shall utilize all of his construction experience and shall consult with the Engineer regarding items in the Plans and Specifications which may be altered to the benefit of the work.

A. Materials, Services and Facilities: It is understood that except as otherwise specifically stated in the specifications, the Contractor shall provide and pay for all materials, labor, tools, equipment, water, light, power, transportation, superintendence, temporary construction of every nature, and all other services and facilities of every nature whatsoever necessary to execute, complete and deliver the work within the specified time.

Materials must be approved for use before being purchased by the Contractor. The Contractor shall submit to the Engineer a list of such materials or products, and the shop drawings, together with such samples as may be necessary for determination of their acceptability and obtain material/product approval. No request for payment will be approved until this list has been received and approved by the Spartanburg Sanitary Sewer District Engineering Department. Delay caused by obtaining approvals for substitute materials will not be considered justifiable grounds for an extension of construction time.

B. Shop Drawings: Shop Drawings are original drawings prepared by the Contractor, or a subcontractor or supplier, which illustrate some portion of the work and show fabrication, layout, and setting or erection details. Shop drawings shall also include manufacturer's catalog sheets, brochures, diagrams, schedules, performance charts, illustrations and other standard descriptive data, as required. Shop drawings shall be clearly marked to identify specific materials, finishes, products or models, and shall show all required dimensions and clearances, performance characteristics and capacities, wiring diagrams and controls.

1) The Contractor shall review and check all shop drawings for accuracy and conformance with the contract documents. The Contractor's review shall include verifying field measurements, field construction criteria, dimensions, catalog numbers and similar data. Prior to submission to the Engineer, all shop drawings shall be marked, stamped or otherwise certified as approved by the Contractor, dated and signed or initialed. Any shop drawings not so marked will be returned to the Contractor without the Engineer's review.

2) The Contractor shall schedule the submission of shop drawings to allow sufficient time for review by the Engineer and the Spartanburg Sanitary Sewer District (hereinafter referred to as the "District"), corrections and resubmissions by the Contractor, and re-checking by the Engineer/District, as necessary. The Engineer will review shop drawings within two (2) weeks

from date received.

- 3) A minimum of two (2) copies of each submittal indicating approval by the Engineer shall be submitted to the District.
- 4) The Contractor shall not begin fabrication or work which requires submittals until return of submittals with the full approval.

1-03 SOURCE OF SUPPLY AND QUALITY OF MATERIALS

The source of supply of all materials and equipment shall be submitted to the District's Engineering Department for review before orders are placed. Suppliers of reinforcing steel, fabricated metal work, and metal castings may be required to submit guarantees of conformity with the Drawings and Specifications. If required, representative preliminary samples of the character and quality prescribed shall be submitted by the Contractor or producer for examination and tested in accordance with the methods specified below. Only materials conforming to the requirements of the specifications shall be used in the work. Any materials proposed to be used may be inspected or tested during their preparation and use. If, after inspecting and testing and/or trial, it is found that initial sources of supply do not furnish an acceptable product in conformity with the Specifications, the Contractor shall be required to furnish materials that comply with the specifications. No materials, which after approval have become unfit for use, shall be used in the work or remain on the jobsite.

1-04 SAMPLES AND TESTING OF MATERIALS

Testing and certification of materials may be required by the Engineer if the quality of such materials are in question. In the event the materials do not meet specifications, the Contractor shall pay for the testing and provide materials which meet the specifications. If the materials meet specifications, District will pay for the testing. Unless otherwise specified, materials tests shall be made in accordance with the standards of the American Society for Testing and Materials (ASTM), and by a commercial testing laboratory approved by the Engineer. Reports of tests shall promptly be furnished to the Engineer. Test shall be arranged by the Contractor as directed by the Engineer. The cost of all specified inspection and testing of materials shall be paid by the Contractor.

1-05 PRECONSTRUCTION CONFERENCE:

- A. Upon SCDHEC construction permit issuance, if applicable, the Consulting Engineer shall contact the District's Project Manager to schedule a preconstruction conference. The conference shall be scheduled no less than three (3) days in advance.
- B. The conference shall be attended by:
 - District Project Manager

- District Engineering Field Technician (EFT)
- Representative of Consulting Engineer
- Representative of the Contractor and/or the Contractor's Project Foreman
- Representative of any Subcontractors involved with project.

C. At least two (2) days prior to the preconstruction conference, the Consulting Engineer shall provide the District Project Manager with four sets of plans and specifications stamped "issued for construction". Project cut sheets and applicable shop drawings shall be provided as soon as possible after the preconstruction conference and prior to starting construction.

1-06 INSPECTION: The Engineer shall provide for the inspection of all materials used and all work done under these specifications, by assistants and the District EFT(s) under his direction. Such inspection may extend to any or all parts of the work and to the preparation or manufacture of materials used, whether within the limits of the work or at any other place. The Contractor shall furnish the Engineer all information relating to the work and to the materials which the Engineer may deem necessary or pertinent and with such samples of materials as may be required. The Contractor shall, at his own expense, supply labor and assistance as may be necessary in handling material for proper inspection.

- A. The representatives of the Owner, Engineer and any State, Federal or other agency having jurisdiction over the work, shall have access to the work wherever it is in preparation or progress, and the Contractor shall provide proper facilities for such access and inspection.
- B. The District EFT shall be authorized to inspect all work done and all materials furnished, including preparation, fabrication and manufacture of the materials to be used. The District EFT shall not be authorized to alter or waive requirements of the Drawing and Specifications. The District EFT shall call to the attention of the Contractor to failures of the work and/or materials to conform to the Drawings and Specifications. The District EFT may reject materials or suspend work until questions at issue can be referred to, and decided by, the District Project Manager or designated representative. The presence of the District EFT shall in no way lessen the responsibility of the Contractor.
- C. The Contractor shall furnish all necessary facilities and assistance to make any examination of the complete work if such examination is deemed advisable by the Engineer. If any of the work is found defective in any respect, the Contractor shall defray the expense of the examination and satisfactory reconstruction. If the work is found acceptable, the expense of the examination shall be added to the Contractor's final estimate.
- D. Work covered up without consent or approval of the District must, if required by the District EFT, be uncovered for examination and properly restored at the Contractor's expense.
- E. If the Specifications, the Engineer's instructions, codes, laws, ordinances, or any

public authority require any work to be specially tested or approved, the Contractor shall give the Engineer timely notice of its readiness for inspection; and, if the inspection is by an authority other than the Engineer, of the date fixed for such inspection.

- F. Final Inspection: Upon notice from the Contractor that work is complete, the Engineer and the will make a final inspection, and will notify the Contractor in writing of all defective, incomplete or otherwise unacceptable work revealed by the inspection. The Contractor shall immediately correct all such deficiencies to the satisfaction of the Engineer and District. The Engineer will then certify the project in writing to SCDHEC, copying the District, and request a final regulatory agency inspection.

1-07 VERIFICATION OF DIMENSIONS AND ELEVATIONS:

Dimensions and elevations indicated on the drawings in reference to existing structures, location of utilities, sewer inverts, or other information on existing facilities, are the best available data obtainable but are not guaranteed by the Engineer. The Engineer will not be responsible for their accuracy. Before proceeding with any work dependent upon the data involved, the Contractor shall field check and verify all dimensions, grades, inverts, lines, elevations, or other conditions of limitations at the site of the work to avoid construction errors or damage to existing facilities. If any work is performed by the Contractor, or any subcontractors, prior to adequate verification of applicable data, any resultant extra cost for adjustment of work necessary to conform to existing conditions, or damage to existing facilities, shall be assumed by the Contractor without reimbursement or compensation by the Owner or the District.

If the Contractor, in the course of the work, finds any discrepancy between the drawings and the physical conditions of the locality, or any errors or omissions in drawings or in the layout as given by survey points and instructions, he shall immediately inform the Engineer, in writing. The Engineer will promptly investigate the reported conditions and, after District approval, shall issue such instructions as may be necessary for the proper execution of the work. Any work done after such discovery and prior to receipt of such instructions shall be at the risk of the Contractor.

1-08 CARE OF EXISTING FACILITIES:

In executing the work, the Contractor shall exert every effort not to damage any existing utilities or the Owner's existing facilities or to break into them. Any damage that is done thereto shall be promptly repaired by the Contractor or by the Owner, at the Owner's option, and at the Contractor's expense. Damage to the District's lines shall be repaired by the District. The contractor shall not interrupt or interfere with the operation of existing utilities or facilities during construction except when absolutely necessary. When this is the case, he shall consult with the Engineer, Owner and the utility company as to procedure, and shall be governed by their decision. Any damage done shall be promptly reported to the affected

utility for repair. Damage to the District's existing facilities shall be repaired promptly.

- A. The Engineer does not guarantee that all existing facilities such as buildings, fences, pipelines, electrical lines, conduit, telephone cable, service connections, or other facilities are shown on the plans. It shall be the Contractor's responsibility to locate and protect all such existing facilities prior to beginning construction.
- B. Contractor's Responsibilities. Contractor shall conduct his operations in a manner and sequence which will provide for the continued transportation of wastewater flows during construction of this project. Contractor shall take all actions required to prevent discharge of sewer flow from the system to the ground or any stream. Any construction actions that impede or interrupt flow shall be carefully executed and monitored to prevent surcharging and overflow.
- C. Any existing surface or subsurface improvements, such as pavement, curbs, sidewalks, pipe or utilities, footings, or structures (including portions thereof), trees and shrubbery, not indicated on the drawings or noted in the specifications as being removed or altered shall be protected from damage during construction of the project. Any such improvements damaged during construction of the project shall be restored to a condition equal to that existing at time of award of contract.
- D. Any such improvements damaged during construction of the project shall be restored to a condition equal to that existing at time of award of contract. All repairs to utility services shall be coordinated with the applicable utility company, and shall be made in strict accordance with their requirements.

1-09 CONNECTING TO EXISTING WORK:

It shall be the express responsibility of the Contractor to connect his work to each part of the existing work or work previously installed as required by the drawings and specifications to provide a complete installation. Connections to existing sewer lines, prior to completion, may be allowed by the District on a case by case basis where requested by the Contractor and approved by the District Project Manager; otherwise, connections to existing sewer lines shall be made only after all inspections are completed and all punch list items have been adequately addressed. During construction of new sewer lines, no physical connection to any existing pipeline by open channel or sawed off pipe shall be allowed until all lines upstream and/or downstream of connection have been approved for use by DHEC.

1-10 INSURANCE:

The Contractor shall not start work under this contract until he has obtained all the insurance required under this paragraph and such insurance has been approved by the Owner. The Contractor shall not allow any subcontractor to start work on his subcontract until the insurance required of the subcontractor has been so obtained and approved.

- A. Compensation and Employer's Liability Insurance: The Contractor shall procure and maintain during the life of the contract the statutory Workmen's Compensation and Employer's Liability Insurance for all of his employees to be engaged in work on the project under the contract. The Contractor shall require all subcontractors to provide Workmen's Compensation and Employer's Liability Insurance of all their employees to be engaged in such work.
- B. General Public Liability and Property Damage Insurance: The Contractor shall procure and maintain during the life of the contract General Public Liability and Property Damage Insurance, including vehicle coverage, to protect him from all claims for destruction of or damage to property, arising out of or in connection with any operations under the contract, whether such operations be by himself or by any subcontractor under him, or anyone directly or indirectly employed by the Contractor or by a subcontractor under him. The amount of such insurance shall be not less than the following limits of liability.
- 1) \$500,000 for all damages arising out of bodily injury, including death, at any time resulting therefrom, sustained by any one person in any one accident; and \$500,000 aggregate for any such damages sustained by two or more persons in any one accident.
 - 2) \$200,000 for all property damage sustained by any one person in any one accident; and \$200,000 aggregate for any such damage sustained by two or more persons in any one accident.
- C. Special Hazards Insurance: Where special hazards are encountered in the work under this contract, such hazards shall be covered by a rider to the policy or policies required under subparagraph B in an amount not less than those stipulated under subparagraph B. The Contractor shall be responsible for procuring this insurance before performing any work involving special hazards.
- D. Flood Insurance: The Contractor shall procure and maintain during the life of the contract adequate flood insurance to cover all work on this project.
- E. Certificates of Insurance: Prior to starting any work, the Contractor shall furnish the Owner with certificates showing the type, amount, class of operations, effective dates and expiration dates of all insurance policies. Each certificate shall contain the following statement: **"The insurance covered by this certificate shall not be cancelled or materially altered, except after ten (10) days written notice has been received by the Owner."**
- F. Railroad Insurance:
- 1) The Contractor shall be able to furnish the Railway Company the following:
 - a) Certificate of Workmen's Compensation or Employer's liability insurance according to the laws of the State.

- b) Certificate of the contractor's Public Liability Insurance, to protect the Contractor and Subcontractor:
 - 1) For loss of life or injury to any one person in an amount not less than \$150,000 for any one person and not less than \$300,000 for any one accident.
 - 2) For property loss or damage in an amount not less than \$150,000 for any one accident and not less than \$300,000 aggregate.

- c) The original policy of Railroad Protective Liability Insurance naming the Railway Company as the insured.
 - 1) For loss of life or injury to any one person in the amount not less than \$150,000 for any one person and not less than \$300,000 for any one accident.
 - 2) For property loss or damage in an amount not less than \$150,000 for any one accident and not less than \$300,000 aggregate.

SECTION 2

RIGHTS-OF-WAY AND EASEMENTS

2-01 SCOPE:

This section covers the requirements and work pertaining to the rights-of-way and easements necessary for the construction of the project.

2-02 WORK ON RIGHTS-OF-WAY AND EASEMENTS:

- A. The Owner will obtain all land and rights-of-way necessary for all work under this contract, except for County, Town or City roads or streets. If all land and rights-of-way are not obtained before construction begins, the Contractor shall start work only upon such land and rights-of-way previously obtained by the Owner, and no claims for damages will be allowed because of such delay. If the Owner is unable, for any reason, to obtain the land and rights-of-way necessary for the work, the contract time will be extended as required to cover the time lost by such delay. The Contractor shall secure copies of all applicable right-of-way plats to be kept at the job site during construction.
- B. Contractor shall confine his construction operations to the immediate vicinity of the location shown on the plans and in no case shall he encroach beyond the limits of the Owner's property or rights-of-way. The exact location of the rights-of-way limits shall be shown on the rights-of-way plats which will be furnished to the Contractor. He shall place materials, equipment, supplies, etc., so as to cause the least possible damage to property and interference with traffic. His method of operation and placing of equipment shall be subject to the approval of the Engineer. Any damage done to property outside the rights-of-way limits shall be the financial responsibility of the Contractor. Any vehicular access to right-of-way which crosses private property shall be by written permission of the property owner with copy of same provided to the Spartanburg Sanitary Sewer District Engineering Field Technician (EFT).
- C. It shall be the duty of the Contractor to locate the limits of the rights-of-way, or property lines, prior to beginning construction. He shall be solely responsible for any damage to trees, crops or other property outside the boundaries of the rights-of-way and shall make satisfactory settlement for any damage directly with the property owner involved.
- D. Clearing and Grubbing. Contractor shall consult with the Spartanburg Sanitary Sewer District (hereinafter referred to as the "District") Engineering Department and Engineer prior to beginning clearing and a full understanding is to be reached as to procedure. Contractor shall then conduct clearing and grubbing operations in strict accordance with these agreements

- E. All operations shall be conducted with full consideration of all proper and legal rights of the Owner, adjacent property owners and the public, and with the least possible amount of inconvenience to them. Care shall be taken to protect adjacent property.
- F. Contractor shall perform all clearing and grubbing work required for the installation of the complete work. Clearing shall consist of the removal and disposal of all pavement, stumps, trees, brush, debris, or other such materials in the path of the work.
- G. No burying of cleared debris on the right-of-way will be allowed.
- H. Any vehicular access to the right-of-way which crosses private property shall be by written permission of the property owner with copy of same provided to the Engineering Field Technician.
- I. Erosion control measures as shown on the plans, and/or as required by SECTION 10: GRASSING AND EROSION CONTROL, shall be put in place during clearing and grubbing and before trench excavation.
- J. Clearing Along Right Of Way: Where trees, brush, stumps or exposed roots exist within rights-of-way, the full width of the right-of-way shall be completely cleared and grubbed. Stumps shall be removed and roots shall be grubbed at least two (2) feet below the ground surface.
- K. Burning Of Cleared Material shall be in strict accordance with all applicable local, state and federal regulations pertaining to open burning and smoke abatement. Prior to burning, approval and where applicable written permits, must be obtained from all applicable agencies;
- L. Minor Structures may exist on the right-of-way. The disposition of the structures shall be so noted as shown on the plans by either; (1) left in place in a condition equal to prior to construction; (2) removed and disposed of by the Contractor; (3) removed for construction and replaced in a condition equal to prior to construction; (4) relocated as shown on the plans. If the Contractor notes structures on the right-of-way that are not shown on the plans or the disposition is not noted on the plans, he shall contact the District Engineering Department as to which of the above methods shall be followed.
- M. Removal and Replacement of Fences: Fences shall be removed as required by construction and replaced to property owners' satisfaction with materials as good as that which was removed. Temporary fencing, as required, shall be installed to property owners' satisfaction until permanent fencing can be erected.
- N. Trees or Shrubbery along the highways, roadways, and streets shall not be disturbed unless absolutely necessary. Approval must be obtained from the District Engineering

Department prior to any such removal. Any such trees or shrubbery which may be necessary to be removed shall be heeled in and replanted. Heeling in and replanting shall be done under the direction of an experienced nurseryman. Trees or shrubbery that die within twelve (12) months of replacement shall be replaced by the Contractor at no expense to the District.

O. Construction Operations: All work along highways, streets and roadways shall be in accordance with the following sequence of construction operations, so as to least interfere with traffic.

1) Trenching, Laying and Backfilling: It is the intent of these specifications that there shall be minimum interruption to traffic and all traffic control shall be in accordance with the regulations and requirements of the South Carolina Department of Transportation, Spartanburg County and/or the local jurisdiction. By entering into the construction agreement, the Contractor agrees to hold the District harmless from and against any and all liabilities and claims of any nature whatsoever relating to or arising from traffic control. The trench shall not be opened any further ahead of pipe laying operations than is necessary for proper laying operations, and trenches shall be progressively backfilled and consolidated, and excess material removed immediately behind laying operations so as not to interfere with traffic.

2) Shaping: Immediately after backfilling operations are complete, any damaged cut and fill slopes, side ditches and ditch lines, shall be reshaped and returned to original level and condition. Topsoil, sod and any other materials removed from shoulders shall be replaced in accordance with the requirements of, and to the full and complete satisfaction of the South Carolina Department of Transportation, Spartanburg County, the local jurisdiction, and the District.

3) Grassing: See SECTION 10: GRASSING AND EROSION CONTROL.

4) Capability: When installing pipelines and appurtenances, sufficient personnel and equipment will be provided so as to simultaneously carry out all of the above operations.

2-03 WORK ON STATE AND COUNTY HIGHWAYS OR ROADS, TOWN OR CITY ROADS OR STREETS, RAILROAD AND OTHER UTILITY RIGHTS-OF-WAY:

A. The Contractor shall not begin excavation, grading, fill, storm drainage, paving and any other construction or installations on any property or in any right-of-way of streets, highways, public carrier lines, utility lines (either aerial, surface or subsurface), etc. until the necessary permits are secured. The Contractor shall conform to all

requirements of the authorities having jurisdiction and to the applicable requirements of the specifications. Contractor shall make all necessary arrangements with the proper authorities, including approval of construction methods, etc., and shall pay all costs charged in connection with work. Contractor shall notify the South Carolina Department of Transportation at least 24 hours in advance of any work performed on State roads and shall notify Spartanburg County Roads and Bridges at least 24 hours in advance of any work performed on County roads.

- B. The Contractor shall provide full time flagmen, with appropriate flags and signage, at all times when work is in progress along highways. Suitable warning and descriptive signs shall be placed at each end of the working area while work is in progress along highways. These signs shall be well tended, and shall be placed at sufficient distances from the work so that ample warning is given to approaching traffic. Signs shall be adequately lighted at night. All traffic control devices and methods shall comply with the latest edition of the Manual on Uniform Traffic Control Devices.
- C. Where pipe is installed in open cut across a highway, the cut shall be immediately backfilled and all work of repairing the pavement completed within the same week that it is cut. The Contractor shall keep at least one full lane open for traffic at all times. Any subsequent settlement shall be immediately corrected and repaired. Refer to SECTION 9.03 for paving and surfacing specifications.
- D. Where a pipeline crossing under a highway is installed within encasement pipe, the encasement pipe shall be provided as specified in SECTION 8-02: BORING.
- E. Unless otherwise indicated, no excavated material shall be placed on the pavement side of the ditch along highways. The least possible amount of ditch shall be left open when work is not in progress, and equipment shall be removed from the pavement and shoulders during shutdown periods. Shoulders of roadways shall be left in good acceptable condition, and all disturbed topsoil and grass shall be replaced.
- F. The Contractor shall not begin work on any property of any Railroad until the District has secured necessary permits. Contractor shall conform to all requirements of the Railroad, or its authorized representatives, in the construction of this portion of the work. The Contractor shall also pay the cost of flagmen or other expenses of the railroad in protecting rail or vehicular traffic. He shall notify the railroad of the time that the work will be done and shall not begin work until authorized by Railroad officials.

2-04 RESTORATION OF RIGHTS-OF-WAY:

- A. During construction, the Contractor shall maintain the site and adjacent public and private property, including streets and highways, free from accumulations of waste debris, rubbish and dirt caused by his operations. Dry materials and rubbish shall be

wet down as necessary to prevent blowing dust.

- B. Immediately after completion of the work, or any substantial unit or portion of it, the Contractor shall remove all unused material, refuse and dirt placed by him in the vicinity of the work and shall leave the premises in a neat and orderly condition, satisfactory to the Engineer.
- C. The right-of-way shall be restored to the original condition. Horizontal benches shall be provided to facilitate access to the site and shall be located where directed by the Engineer and the District. Fill material, where required, shall be free of grass, roots, rock and other objectionable material and shall be spread evenly and properly compacted. The entire right-of-way shall be graded, dressed off and cleaned up to the satisfaction of the Engineer, the District, other agencies having jurisdiction, and property owner, where applicable.
 - 1) Where work is along streets or highways and dirt has been placed on the pavement, the pavement shall be swept clean of all dirt after backfill has been completed.
 - 2) Site: The Contractor shall clean up behind the work as much as is reasonably possible as the work progresses, but in no case shall the pipe laying operation be more than 1000 feet ahead of complete cleanup. Federal regulations require that temporary stabilization measures be implemented within 14 days of the time when construction activities have been completed in an area of a phased project.
 - 3) Upon completion of the work and before acceptance of the Final Payment for the project by the Owner, the Contractor shall remove all his surplus and discarded materials, excavated material and rubbish from the roadways, sidewalks, parking areas, lawns and all adjacent property; shall restore, in an acceptable manner, all property, both public and private, which has been disturbed or damaged during the prosecution of the work; and shall leave the whole site in a neat and presentable condition.
 - 4) Except where specifically directed otherwise by the property owner, the entire construction right-of-way shall be provided with a permanent grass cover within 30 days after backfilling. Topsoil shall be replaced and seed planted, fertilized and watered until a grass cover satisfactory to the Engineer and property owner is obtained. If necessary, a temporary grass cover shall be provided until a permanent cover can be established. Grassing shall be as specified in SECTION 10. If required by the property owner, shrubbery shall be replaced to the satisfaction of the Engineer and the property owner.

SECTION 3

MANHOLES

3-01 SCOPE:

This section covers the construction of manholes, including frames, covers and steps as shown in plans and as specified herein.

3-02 DESIGN CRITERIA

Manholes and appurtenances shall be of the type and size shown on the plans. Manholes shall conform to the requirements of ASTM/AWWA C478.

Reference Standards of the American Society of Testing of Materials (ASTM)

A48 / A48M - 03(2008) Standard Specification for Gray Iron Castings

C32-05 Standard Specification for Sewer and Manhole Brick (Made from Clay or Shale)

C443-03 Standard Specification for Joints for Concrete Pipe and Manholes, Using Rubber Gaskets

C478-03a Standard Specification for Precast Reinforced Concrete Manhole Sections

C497-03a Standard Test Methods for Concrete Pipe, Manhole Sections, or Tile

C923-02 Standard Specification for Resilient Connectors Between Reinforced Concrete Manhole Structures, Pipes and Laterals

C924-02 Standard Practice for Testing Concrete Pipe Sewer Lines by Low-Pressure Air Test Method

C990-03a Standard Specification for Joints for Concrete Pipe, Manholes, and Precast Box Sections Using Preformed Flexible Joint Sealants

C1214-02 Standard Test Method for Concrete Pipe Sewer lines by Negative Air Pressure (Vacuum) Test Method

3-03 MATERIALS:

Shop drawings and related data for manhole material, frames, covers and steps shall be submitted to the Engineer for review.

A. Manhole Material shall be precast concrete unless otherwise approved by the Engineer and the Spartanburg Sanitary Sewer District (hereinafter referred to as the "District"). The minimum diameter of all manholes shall be four feet. The minimum wall thickness shall be five inches.

- 1) Precast Concrete Manholes shall conform to ASTM C478, and shall consist of precast reinforced concrete riser sections, a monolithic base section, and an eccentric, concentric or flat slab top section as required, all in accordance with

the details shown on the plans. Minimum compressive strength of concrete for all sections shall be 4000 psi. Maximum allowable absorption of concrete shall be 8 percent of the dry mass. Manhole interior walls, tables and inverts shall be a smooth surface free of voids, depressions, chips, rough edges and high spots. Pipe openings shall be provided in base sections as required. Lifting holes may be provided in each section for ease of handling. Concentric cones or flat tops may be used for manholes less than five feet in depth; provided specific approval has been given by the District Engineering and Maintenance & Construction (M&C) Departments. Refer to CONSTRUCTION DETAIL No. 1.

- 2) Joint Sealant shall be either by butyl rubber ring joint, 1-inch diameter, conforming to ASTM C990, or rubber O-ring gaskets conforming to ASTM C443, latest revision. Cement mortar joints will not be acceptable, except that each joint shall be wiped inside the manhole with cement mortar after assembly. Refer to CONSTRUCTION DETAIL No. 2
- 3) Inverts shall be factory constructed precast concrete or field constructed using brick and cement mortar. Tables on sides of inverts shall be constructed of brick and cement mortar not less than ½ -inch thickness with 1:12 slope from the manhole wall to the trough with rough brushed finish. At end manholes, a "false" invert shall be constructed to drain accumulation of water from manhole bottom. Troughs shall be trowelled smooth and free of high or low spots and rubbed smooth after setting up. Refer to CONSTRUCTION DETAILS No. 1 and No. 3.
- 4) The minimum manhole inside diameter shall be 4'. Larger manholes are specified for larger diameter sewer pipe, or when inside drops are constructed. Refer to Table 3.1 below and CONSTRUCTION DETAIL No. 3.

Table 3.1

Line Size	Standard Manhole ID	Inside Drop Manhole ID
< 12"	4'	5'
12" – 15"	5'	6'
15" – 24"	6'	8'
>24"	8'	Not Approved

- 5) Brick shall be common red clay and conform to ASTM C32, Grade MS, standard size 2-1/4 x 3-3/4 x 8 inches, and shall be free of chips, cracks and other defects that impair strength or usefulness. There shall be no more than four courses of brick used to bring the manhole ring and cover to the proper elevation.
- 6) Grade Rings may be used in lieu of brick for elevation adjustment. Grade rings shall conform to ASTM C478 and shall be made of reinforced concrete with a

minimum compression strength of 4,000 psi. Maximum elevation adjustment with grade rings shall be 9". If additional elevation adjustment is required, a new cone section of the proper height shall be installed.

- 7) Concrete used in manhole construction shall be composed of Portland cement, sand, coarse aggregate, water and approved admixtures, designed to provide a minimum compressive strength of 4,000 psi at 28 days, unless otherwise noted.

B. Frames and Covers shall be of gray cast iron conforming to ASTM A48 (latest version), Class 30, and shall conform in general to the details for each type shown on the plans. Casting shall be of uniform quality and free from blowholes, porosity, hard spots, shrinkage distortion and other defects. Frames and covers shall be smooth, well-cleaned and given a bituminous coating which is tough and tenacious when hot and not tacky or brittle. All castings shall be manufactured true to pattern, and component parts shall fit together in a satisfactory manner. Frames and covers shall have machined bearing surfaces to prevent rocking. The following frame and covers shall be specified for the application indicated:

- 1) Standard Frame and Cover shall be USF-668, KL as manufactured by U.S. Foundry or V-1384 as manufactured by East Jordan Iron Works;
- 2) Waterproof Frame and Cover shall be USF-668, KL-BWTL as manufactured by U.S. Foundry or approved bolt-down unit compatible with V-1384 as manufactured by East Jordan Iron Works;
- 3) Flat Slab Frame and Cover shall be USF-1261, KL as manufactured by U.S. Foundry or V-1384-4 as manufactured by East Jordan Iron Works;

To be considered an approved equal, the frame and cover must be interchangeable with approved frames and covers and meet applicable weight criteria. Frames and covers shall be certified by the manufacturer for use under AASHTO H-20 loading conditions as a minimum. Refer to CONSTRUCTION DETAIL No. 4.

C. Manhole Steps shall be of composite plastic steel construction. Minimum design live load of steps shall be a single concentrated load of 300 pounds. Steps shall have nonskid top surfaces, and shall be designed so that the foot cannot slip off the end. Steps shall have a minimum cross-sectional dimension of 1-inch, and a minimum width of 10 inches. Steps shall be evenly spaced on 16-inch centers with each step embedded in the wall a minimum of 3 inches. Each step shall project a minimum of 4 inches from the wall as measured from the point of embedment. Composite steel steps shall consist of a 1/2-inch deformed steel reinforcing rod encapsulated in a polymer polypropylene plastic. Reinforcing rods shall conform to ASTM A615, Grade 60, and polypropylene plastic shall conform to ASTM D2146, Type II, Grade 16906

D. Corrosion-proof coatings: The District will require corrosion-proof linings for

installations subject to high levels of hydrogen sulfide gas, where a sewer force main discharges into a manhole, or in any installation where corrosion of the concrete manhole structure may be expected. If a corrosion-proof structure is required, all exposed interior surfaces and structures, including the interior of the frame and cover, walls, bench and invert shall be protected. The method of providing a corrosion-proof structure and the sub-contractor who will be performing this specialized work shall be submitted to the Engineering and the M&C Departments for approval. Refer to SECTION 14 of this document for approved technologies and other requirements related to the protection of manholes from corrosion.

3-04 INSTALLATION:

- A. Manholes shall be installed: at the end of each line; at all changes in grade, size, or alignment; at all intersections; and at distances not greater than four hundred (400') feet for gravity wastewater lines fifteen (15") inches or less, and five hundred (500') feet for gravity wastewater lines eighteen (18") inches to thirty (30") inches. Greater spacing may be permitted in larger wastewater lines. Clean outs may be used only for special conditions and shall not be substituted for manholes.
- B. Precast Concrete Manholes: Each section shall be handled and installed in such a manner and by such means as to prevent damage. All manhole sections damaged during handling and installation will be rejected as directed by the Engineer, and replaced at no additional cost to the Owner. All lifting holes shall be plugged and sealed watertight as recommended by the manufacturer.
 - 1) Base sections shall be installed on a firm 6-inch washed stone foundation so prepared to prevent settlement and misalignment. Pipe openings shall be placed at the exact elevation and location to receive entering pipes. Base section shall be set such that the center of the manhole will coincide with the intersection of the incoming and outgoing pipes. The resulting angle shall be no less than 90 degrees and so constructed that both halves of the trough shall be of equal length and radius. Manhole bases set off center shall be removed and reset.
 - 2) Riser and top sections shall be installed plumb and such that all manhole steps are in alignment. Joint sealant shall be of the type specified above. Joints shall be made in accordance with the manufacturer's recommendations, and to insure a watertight installation. Each joint inside the manhole shall be wiped with cement mortar plaster after installation.
 - 3) Pipe connections shall be made by a flexible synthetic rubber boot mechanically clamped to the manhole and to the pipe to provide a watertight seal and designed to accommodate pipe movement up to 2 inches radially or 22 degrees angularly in any direction. The synthetic rubber boot shall have a minimum wall thickness of 3/8 inch. The synthetic rubber material shall conform to ASTM C-923 (latest version). Bands, clamps and other metal accessories shall be of

Series 304 stainless steel. Approved manhole boots shall be Kor-N-Seal as manufactured by NPC or PSX Direct Drive as manufactured by Press-Seal. Refer to CONSTRUCTION DETAIL No. 5

C. Outside Drop Manholes. When fall across a manhole exceeds 2 feet from the invert of the upper to the invert of the lower pipe, an outside drop shall be constructed. Refer to CONSTRUCTION DETAIL No. 6

- 1) The outside drop shall be constructed of SDR-35 PVC pipe and gasketed PVC fittings.
- 2) At the discretion of the Engineering Field Technician, the lower drop fitting may enter the manhole just above the table, and a suitable “trough” constructed of brick and mortar.
- 3) The lower fitting shall be supported by a concrete pad which is poured on a compacted washed stone base;
- 4) The drop pipe shall be supported with stainless steel straps spaced 4’ apart. If the drop pipe is less than 4’ in length, a minimum of two straps shall be installed, evenly spaced on the length of the pipe.
- 5) After assembly of the drop structure, and approval by the Engineering Field Technician, the entire assembly shall be encased in washed stone.

D. Inside Drop Manholes. Where approved by the Engineering Department during the design phase of the project, inside drops may be permitted.

- 1) To provide adequate clearance for access by maintenance personnel, an inside drop manhole will require that the next larger size manhole be used, than would be needed if an outside drop we installed. Refer to CONSTRUCTION DETAIL No. 7.
- 2) The sewer pipe shall be inserted through the manhole wall and sealed with a standard manhole boot;
- 3) A tee shall be placed on the pipe with run vertical, the pipe shall be extended to the manhole table and a 45° bend shall be installed on the end to direct flow into the invert.
- 4) Inside piping shall be secured to manhole wall with stainless steel straps spaced 4’ apart and securely anchored to manhole wall. If the drop pipe is less than 4’ in length, a minimum of two straps shall be installed, evenly spaced along the length of the pipe.

E. Doghouse Manholes. Where shown on the plans or directed by the Engineer, new

sewers shall be connected to existing sewer by installing a "doghouse" manhole over the existing sewer line.

- 1) The doghouse manhole shall be pre-cast with the same requirements as a standard manhole, except that an extended base which is formed at least 1' beyond the outside diameter of the manhole shall added. No field-modified manholes (jack-hammered) shall be allowed. Refer to CONSTRUCTION DETAIL No. 8
- 2) Doghouse manholes shall be required to pass the same vacuum testing as a standard manhole.
- 3) After completion of the new sewer line, a table shall be formed in the doghouse manhole.
- 4) At the discretion of the Engineering Field Technican (EFT), the top section of the old sewer line may be removed and the bottom section allowed to remain to form the invert through the manhole.
- 5) If, for any reason, the EFT determines that the procedure in item 4) above is not feasible, the old sewer line shall be removed from inside the manhole and to and a proper invert formed across the manhole using brick and mortar in the standard manner.

F. Manhole Tops shall be set to the proper elevation as shown on the plans, or as directed by the Engineer.

- 1) Where manholes are located in streets or roads, tops shall be set to conform to the finished grade and slope of the roadway.
- 2) Tops of manholes in yards or other fine grade areas shall be set flush with ground elevation and have a water tight manhole cover, unless otherwise specified or unless otherwise directed by the Engineer. Water tight manhole cover will not be required if ground can be graded to drain away from manhole. Tops may be adjusted a maximum of 9" in elevation using common red clay brick conforming to ASTM C32, Grade MS, Standard size 2-1/4 x 3-3/4 x 8 inches or grade rings conforming to ASTM C478. If more than 9" of height adjustment is needed, the correct height manhole cone shall be installed.
- 3) In cultivated fields, wooded areas and along outfall sewers, manhole tops shall be set a minimum of 18" to 24" above ground elevation, unless the line is subject to flooding or other hazards. In such instances, manhole tops shall be set to the elevations given by the Engineer and shall have bolt-down covers.
- 4) The top elevation of all manholes must be above the fifty year flood plain, or

have bolt-down, watertight manhole covers.

- F. Backfilling Manholes shall conform to requirements for backfilling trenches, Section 4, except that no backfill shall be placed around manholes until all mortar has properly set.
- G. Testing of manholes shall be as specified in SECTION 12-03 of this document.

SECTION 4

GRAVITY SEWER MATERIALS AND GENERAL INSTALLATION

4-01 SCOPE:

This section contains the current specifications for materials to be used in projects to be integrated into the Spartanburg Sanitary Sewer District (hereinafter referred to as the "District"). The District has established specific manufacturers as the standard for various items within its system. Such standardization is for the express purpose of expediting maintenance procedures. All requests for approval of an "or equal" item must be submitted to the District in writing. All pipe, fittings, and joint materials shall conform to Section C of the AWWA Standards and SCDHEC R.61-67.

Gravity sanitary sewer lines shall be provided as shown on the plans and as specified herein. Clearing, grubbing, installation of manholes, trench excavation and backfill, and cutting and replacing pavement shall be as specified in other sections.

4-02 DESIGN CRITERIA

Reference Standards of the American National Standards Institute (ANSI), the American Society of Testing of Materials (ASTM), and the American Waterworks Association (AWWA).

ASTM A-746, ANSI A21.50 (AWWA C150) and of ANSI A21.51 (AWWA C151)
Ductile Iron Pipe with a standard outside coating of coal tar or asphalt base material

ANSI A21.11 (AWWA C111). ANSI A21.10 (AWWA C110) or ANSI A21.53 (AWWA C153) joints for ductile iron pipe and fittings

ASTM D638 – Test Method for Tensile Properties of Plastics.

ASTM D3034 or D3033 PVC gravity wastewater pipe and fittings

ASTM D2321 Standard Practice for Underground Installation of Thermoplastic Pipe for Sewers and other Gravity-Flow Applications

ASTM D2412 - Standard Test Method for Determination of External Loading Characteristics of Plastic Pipe by Parallel-Plate Loading.

ASTM D3262 - Standard Specification for "Fiberglass" (Glass-Fiber-Reinforced Thermosetting-Resin) Sewer Pipe.

ASTM D3681 – Standard Test Method for Chemical Resistance of "Fiber glass" Pipe in

Deflected Condition.

ASTM D4161 - Standard Specification for "Fiberglass" (Glass-Fiber-Reinforced Thermosetting-Resin) Pipe Joints Using Flexible Elastomeric Seals.

4-03 MATERIALS:

A. Pipe for gravity sewers shall be either ductile iron, polyvinyl chloride (PVC), or fiberglass polymer-mortar, except where other material is specifically called for. Pipe material shall be specified as follows:

1) Ductile Iron Pipe for gravity sewers shall be designed to conform to ASTM A-746 latest version and ANSI 21.50 (AWWA C150), latest revision. Pipe shall be designed for a rated working and pressure of 150 psi plus a surge allowance of 100 psi, unless otherwise noted, and a thickness class of 50 through 56 as required by the laying condition and depth of cover. Pipe shall be slip joint or mechanical joint ends conforming to ANSI A21.10 and/ or A21.11, latest revision, except where other type ends are shown or specified.

a) Ductile iron pipe for sanitary sewers shall be coated on the inside with 40 mils of Protecto 401 Ceramic Epoxy and outside with a standard bituminous coating.

b) All bells and spigots for sanitary sewer pipe shall be coated with a minimum of 8 mils of Protecto 401 Joint Compound or approved equal.

c) Material shall be subject to such testing as the Engineer may require should its acceptability be questioned.

2) Polyvinyl Chloride Pipe (PVC):

a) When approved by the District, PVC pipe may be used for sewer projects within the District's jurisdiction for the following applications:

1) Gravity sewer collection lines serving residential or commercial users.

2) Individual service laterals for applications described in 1) above.

3) Trunk lines.

b) PVC pipe shall not be used for:

- 1) On any project in which the pipeline could carry wastewater having a temperature greater than 120°F.
 - 2) On any project in which the pipeline would or has the potential to deteriorate due to highly corrosive industrial wastewater.
 - 3) On any project for which use of PVC pipe is disapproved by the District.
- c) PVC pipe and fittings shall be homogeneous throughout and free from visible cracks, holes, foreign inclusions or other injurious defects. The pipe shall be as uniform as commercially practical in color, opacity, density, and other physical properties.
 - d) PVC pipe smooth wall for gravity sewer lines shall be type PSM SDR 35 PVC Stiffness Factor 46 Sewer Pipe conforming to the latest edition of ASTM D3034. Pipe shall be bell and spigot type with elastomeric gasket joints providing a watertight seal. Standard laying lengths of pipe shall be minimum 13.0 feet.
 - e) PVC pipe shall be in accordance with the specifications herein and as manufactured by J-M Manufacturing Inc., Uponor ETI Company, Certainteed Products Corp., North America Pipe Co., Diamond Plastics, or District-approved equal.
 - f) PVC corrugated sewer pipe with a smooth interior shall conform to the requirements of ASTM F-949-93. Sizes 4"-36" minimum pipe stiffness when measured in accordance with ASTM D2412 shall be 50 psi. PVC corrugated sewer pipe shall be manufactured by Uponor ETI, Contech, or District approved equal.
 - g) PVC open profile (ribbed) sewer pipe with a smooth interior shall conform to the requirements of ASTM F-794. Profile wall pipe stiffness shall be a minimum of 60 psi in sizes 8"-12" and 46 psi in sizes 15"-30" when tested at 5% deflection in accordance with ASTM D2412. Pipe shall have ribs running perpendicular to the axis of the pipe. PVC profile wall pipe shall be manufactured by Uponor ETI or District approved equal.
 - h) Material Testing: PVC gravity sewer pipe shall be tested by an independent laboratory acceptable to the Engineer. Tests shall be made in accordance with ASTM D3034, F-794, or F-949 and shall include tests for wall thickness, pipe flattening, impact resistance, pipe stiffness, joint tightness, and extrusion quality. Test results confirming that the pipe meets these specifications shall be furnished to the

Engineer for each shipment of pipe.

3) Fiberglass polymer-mortar pipe

Fiberglass polymer-mortar pipe may be approved for use in the District's gravity collection systems. The Engineer shall request approval for this material as part of the normal submittal process for plans and specifications.

- a) Pipe shall be manufactured either by the centrifugal casting or the mandrel molding process to result in a dense, nonporous, corrosion-resistant, consistent composite structure.
- b) The interior surface of the pipes exposed to sewer flow shall be manufactured using a resin with a 50% elongation (minimum) when tested in accordance with D638. The interior surface shall provide crack resistance and abrasion resistance. The exterior surface of the pipes shall be comprised of sand and resin layer which provides UV protection to the exterior.
- c) Joints: Unless otherwise specified, the pipe shall be field connected with fiberglass sleeve couplings that utilize elastomeric sealing gaskets as the sole means to maintain joint watertightness. The joints must meet the performance requirements of ASTM D4161. Joints at tie-ins, when needed, may utilize gasket-sealed closure couplings.
- d) Acceptable Manufacturers shall be HOBAS Pipe USA, Ameron, or approved equal.
- e) Diameters: The actual outside diameter (18" to 48") of the pipes shall be in accordance with ASTM D3262.
- f) Lengths: Pipe shall be supplied in nominal lengths of 20 feet. Actual laying length shall be nominal +1, -4 inches.
- g) End Squareness: Pipe ends shall be square to the pipe axis with a maximum tolerance of 1/8"

4-04 GENERAL GRAVITY SEWER PIPELINE INSTALLATION

(Refer to SECTION 6 for specific excavation and backfilling requirements).

- A. Pipe Handling: Pipe shall be hauled to the site and distributed along the trench prior to laying. All pipe shall be protected during handling against impact shocks and free fall, and shall be kept clean at all times. Equipment used to handle and transport the pipe shall be of suitable design and properly operated so as to prevent damage to the pipe. All such damage shall be repaired prior to installation of the pipe and to the satisfaction of the Engineer. All damaged pipe shall be rejected and removed from the

work site. Keep gaskets away from oil, grease, excessive heat and direct rays of the sun. Keep PVC pipe covered during storage to prevent damage by sunlight. At the EFT's discretion, any pipe which appears to be faded by exposure to sunlight will be rejected.

B. Installation: Pipe shall be installed in accordance with the best practice, manufacturer's instructions and Engineer's direction. Where the pipeline crosses under or is installed on a highway or railroad right-of-way, work shall be done in accordance with such requirements specified in Section 2, and in accordance with the requirements of the District.

- 1) Gravity sewer pipe in trenches shall be laid to produce a straight line of pipe on a uniform grade. Each pipe shall be laid to form a close joint with the preceding pipe so as to form a smooth inside flow line. All misalignment of pipe shall be corrected by the Contractor at his expense. All pipe shall be laid upgrade with bell end of pipe upgrade.
- 2) Ductile iron pipe shall be installed in accordance with all applicable provisions of ASTM A746, the manufacturer's instructions and at the Engineer's direction. Underground pipe shall be installed using suitable slip joints or mechanical joints as shown on the plans.
 - a) DIP may be laid directly on native soils (with bell holes) unless over-excavation has occurred, in which case aggregate bedding shall be required.
 - b) All adapters necessary for the proper jointing of pipe shall be provided. Connections to other types of pipe shall be made with a gasketed, PVC bell x bell or bell x spigot coupling ("Harco Coupling") or approved equal or watertight coupling suitable for application. The proposed transition coupling shall be submitted to the District Engineering Department for approval. "Fernco" or similar rubber, strapped, couplings are specifically prohibited for use in making main-sewer pipe connections or transitions on PVC or DIP sewers, on NEW pipe installations. "Fernco" or "Flexseal" couplings are only approved for making repairs, including the replacement of a section of damaged pipe.
 - c) Cut ends of Ductile Iron Pipe shall have the Protecto 401 coating repaired using the manufacturer's recommended procedures. Freshly-applied Protecto-401 coating shall be allowed to fully cure prior to the cut pipe being installed.
- 3) PVC gravity sewer line shall be installed in accordance with ASTM D2321, the manufacturer's instructions and as specified herein. Cover over PVC pipe shall be no less than 3 feet. Joints shall form a watertight and airtight seal.

- 4) Rest the full length of each section of pipe solidly on the pipe bedding, with recesses excavated to accommodate bells, couplings and joints.
- 5) Take up and relay pipe that has the grade or joint disturbed after laying.
- 6) Do not lay pipe in water, or when trench conditions are unsuitable for the work; keep water out of the trench until jointing is completed;
- 7) Cut pipe neatly and without damage to the pipe. Bevel edges according to the manufacturer's recommendations.
- 8) Pipe shall be pushed into place by use of a bar or other means approved by the District. Hydraulic excavators, backhoes, or other machinery shall not be used to push slip-joint pipe together.
- 9) Pipe on piers shall be ductile iron, and shall be properly installed in accordance with the details shown on the plans. Refer to SECTION 8 of this document.
- 10) Pipe Connections: Pipe connection to new manholes shall be made by using a flexible synthetic rubber boot mechanically clamped to the manhole and to the pipe to provide a watertight seal and designed to accommodate pipe to 2 inches radially or 22 degrees angularly in any direction. The synthetic rubber boot shall have a minimum wall thickness of 3/8-inch. The synthetic rubber material shall conform to ASTM C433. Bands, clamps, and other material accessories shall be of Series 304 stainless steel as specified in Section 3.

C. Steep Slope Protection

Sewers on 20 percent slopes or greater shall be anchored securely with concrete collars. Refer to CONSTRUCTION DETAIL NO. 9, spaced as follows:

- 1) Not over 36 feet center to center on grades 20 percent and up to 35 percent;
- 2) Not over 24 feet center to center on grades 35 percent and up to 50 percent; and
- 3) Not over 16 feet center to center on grades 50 percent and over.
- 4) All gravity sewer piping which is laid on a slope requiring concrete collars shall be ductile iron.

- D. Connecting to Existing Sewers: Where shown on the plans or directed by the Engineer, new sewers shall be connected to existing sewers either by constructing a manhole over an existing line (doghouse manhole) or by coring through the wall of an existing manhole.

- 1) Doghouse Manhole: After approval of the new sewer line project by the District, the old sewer shall be broken out and the inverts properly formed. On manholes without turns in direction, it will be permitted to use the lower half of the old pipe as the new invert. Refer to Section 3 and CONSTRUCTION DETAIL No. 8.
 - 2) An Existing Manhole shall have an opening cored at the proper elevation and the sewer pipe inserted. Where possible, the sewer extension shall be designed so that manhole penetrations are made above the level of the table, so as to avoid the need to disrupt the existing invert or sewer flow. The hole which is cored in the manhole wall shall be made using the proper mechanical concrete coring equipment which is operated by skilled personnel. The hole shall be cored to receive the properly-sized manhole boot. The area inside the manhole boot shall be completely filled around the pipe with non-shrink grout so as to be watertight. Refer to CONSTRUCTION DETAIL No. 5. A channel shall then be formed over the manhole table, or the table cut through and the channel formed in it, as may be required by the grade.
- D. A pipeline crossing under a highway shall be installed either by open cut, or boring or tunneling. Materials and method of crossing shall be as indicated on the plans for each crossing under the highway and specified in SECTION 9. The appropriate encroachment permit(s) from the local governing authority shall be kept on the job site at all times.
- E. Concrete Protection: Concrete supports, walls and other protective work shall be provided at locations as shown on the plans or as directed by the Engineer.

SECTION 5

SEWER FORCE MAIN: MATERIALS AND GENERAL INSTALLATION

5-01 SCOPE:

This section contains the current specifications for materials to be used in projects to be integrated into the District's system. The District has established specific manufacturers as the standard for various items within its system. Such standardization is for the express purpose of expediting maintenance procedures. All requests for approval of an "or equal" item must be submitted to the District in writing. All pipe, fittings, and joint materials shall conform to Section C of the AWWA Standards and SCDHEC R.61-67.

Force mains shall be provided as shown on the plans and as specified within. Clearing, grubbing, trench excavation and backfill, and cutting and replacing pavement shall be specified in other sections.

5-02 DESIGN CRITERIA

Reference Standards of the American National Standards Institute (ANSI) and American Waterworks Association (AWWA)

A21.5/AWWA C105 Polyethylene Encasement for Gray and Ductile Cast-Iron Piping for Water and Other Liquids.

A21.10/AWWA C110 Gray-Iron and Ductile-Iron fittings, 3" through 48" Inches for Water and Other Liquids.

A21.11/AWWA C111 Rubber Gasket Joints for Cast-Iron and Ductile-Iron Pressure Pipe and Fittings.

A21.15/AWWA C115 Flanged Cast-Iron and Ductile-Iron Pipe With Threaded Flanges.

A21.16/AWWA C116 Fusion-Bonded Epoxy Coatings.

A21.50/AWWA C150 Thickness Design of Ductile-Iron Pipe.

A21.51/AWWA C151 Ductile-Iron Pipe Centrifugally Cast, In Metal Molds or Sand-Lined Molds, for Water or Other Liquids.

A21.53/AWWA C153 Ductile-Iron Compact Fittings for 3" thru 48".

B16.1 Cast-Iron Pipe Flanges and Flanged Fittings, Class 25, 125, 250, and 800.

Reference Standards of the American Water Works Association (AWWA)

C600 Installation of Ductile-Iron Water Mains and Appurtenances.

C900, C905 Polyvinyl Chloride (PVC) Pipe

C901-02, C906 High Density Polyethylene (HDPE) Pipe

5-03 MATERIALS:

A. Ductile Iron Pipe

- 1) Use Class 50, complying with ANSI/AWWA C151/A21.51 and having a minimum pressure rating of 350 psi.
- 2) Use mechanical or push-on joints complying with ANSI/ AWWA C111/A21.11 as modified by ANSI/AWWA C151/A21.51.
- 3) Use rubber gaskets and lubricant complying with ANSI/AWWA C111/A21.11.
- 5) Use only lubricants provided by pipe manufacturer to lubricate gasket.
- 6) All ductile iron pipe which is used in sewer force main applications shall have a internal coating of Protector 401 Ceramic Epoxy which is applied in accordance with the manufacturer's recommended procedures
 - a. Pipe internal coating shall be a minimum of 40 mils of Protecto-401
 - b. All bells and spigots for shall be coated with a minimum of 8 mils of Protecto 401.
- 7) Approved pipe manufacturers are as follows:
 - a. Griffin Pipe
 - b. American Pipe
 - c. U.S. Pipe
 - d. McWane Group (includes Atlantic States and Clow Products)

NOTE: All ductile iron pipe installed in the District shall be of domestic manufacture which is defined as physically manufactured within the limits of the continental United States of America.

- 8) Push-on and Mechanical Joints shall conform to ANSI A21.11/AWWA C111. The pipe is to be supplied in minimum 18 foot lengths with either push-on joints or mechanical joints.
 - a. Push-On Joints as supplied by the following manufacturers are approved.
 - i. Griffin Pipe Product: "Super Bell-Tite" joints;
 - ii American Pipe Product: "Fastite" joint;
 - iii U.S. Pipe Product "Tyton" joint;

- iv McWane Group (includes Atlantic States and Clow Products)
“Tyton” joint 4” – 24” , “Fastite” joint 30” – 36”
 - b. Mechanical Joints in accordance with ANSI A21.11/AWWA C111
- 9) Restrained Joint Pipe shall conform to ANSI A21.11/AWWA C111.
- a. American Pipe Product: Flex Ring.
 - b. U.S. Pipe Product: TR FLEX.
 - c. Griffin Pipe Product: SNAP-LOK.
 - d. McWane Group (includes Atlantic States and Clow Products)
- 10) Push-on Joint Restraint rubber gaskets shall conform to ANSI A21.11/AWWA C111 with stainless steel locking segments vulcanized into gasket, and shall be have an operating pressure of 250 psi or greater. The joints shall be capable of being disassembled and are approved for use only on ductile iron pipe, 4” through 12” diameter inclusive.

Manufacturers:

- a. U.S. Pipe Product: Field-Lok Gasket.
 - b. American Product: Fast Grip
- 11) External Restraint of DIP Bell and Spigot Joints

DIP bell and spigot joints may be restrained by the use of the following external restraint fixtures only if specifically approved by the District’s Maintenance and Construction (M&C) or Engineering Departments. In all cases, the installation of these fixtures shall be performed as specified by the manufacturer, shall be shown on the approved plans, and shall be specifically called out on the Record Drawings.

TABLE 5-1: DIP External Restraint Fixtures

Manufacturer	Model #	Notes
EBAA Iron Sales, Inc.	MEGALUG Series 1700 Restraint Harness	DIP Only
Ford	Uni-Flange Series 1300 or 1390	DIP Only
Sigma Corporation	One-Lok SLDH Restraint Harness	DIP Only

Except as specifically listed above, no other unique, proprietary, or other pipe or joint restraint method shall be approved as an “equal” prior to being submitted for review by the District Engineering Department.

12) Flanged Joints shall conform to ANSI A21.11/AWWA C115. Bolts and nuts shall conform to ANSI A21.11/AWWA C111.

i. Flanged joints are only approved for ABOVE-GROUND installations;

ii. Piping used with flanged joints shall be minimum Thickness Class 53;

B. PVC PIPE

PVC pipe shall be approved in sizes from 4-inch through 12-inch nominal diameter in accordance with AWWA C900, ASTM D2241. PVC pressure pipe in diameters larger than 12-inch is not approved for use anywhere in the District.

1) All PVC pipe shall be designed and manufactured in accordance with AWWA C900, latest revision, from virgin polyvinyl chloride resin meeting cell Class 12454-A or 12454-B as defined in ASTM D1784. All compounds shall qualify for a rating of 4000 psi for water at 73.4 degrees Fahrenheit per the requirements of PPI TR3.

a. PVC (as described and specified above) is the only type of “thermoplastic” pipe approved for use in the District.

b. Thermoplastic PVC pipe is not approved for use in any above-grade application.

2) PVC pipe shall be pressure class 200 (DR14) furnished in ductile iron pipe equivalent outside diameters in 20-foot lengths.

3) Each length of PVC pipe shall bear markings indicating the following information at intervals not to exceed five (5') feet: (1) manufacturer's name or trademark, (2) nominal pipe size and OD base, (3) AWWA material code designation, (4) dimension ratio, (5) AWWA pressure class, (6) AWWA C900 designation, and (7) product record code.

4) All PVC pipe shall be elastomeric-gasket bell-end pipe. One gasket shall be furnished with each length of PVC pipe.

5) Fittings used in the laying of PVC pipe shall be iron fittings as described below. Fabricated or molded PVC fittings will not be acceptable in any application.

6) PVC PIPE INSPECTION

a. Each pipe shipment shall be inspected with care by the Contractor and the District's Engineering Field Technician. Any pipe which is

warped, cracked, discolored, abraded, misshapen, or otherwise damaged shall be considered unsuitable and shall not be used. Any unsuitable material discovered during the inspection or at any other time shall be removed from the job site.

- b. If the load shifted during transport, has broken packaging, or shows rough treatment, each pipe length shall be carefully inspected for damage.
- c. It is assumed that all handling and storage of the PVC pipe by all persons who handle, transport, and/or store, these PVC pipe materials prior to their delivery to the job site is in accordance with the requirements of the Uni-Bell PVC Pipe Association. Any damage resulting from improper handling, transportation, or storage prior to or during the time the pipe material is on the work site shall cause the piping materials to be rejected.

7) SHIPPING, RECEIVING, UNLOADING PVC PIPE

- a. Shipping: All pipe material shall be shipped in a manner to ensure that the pipe is not damaged.
- b. Receiving: When receiving the PVC pipe shipment at the job site, the Contractor shall exercise established precautions.
- c. Unloading: Preferred unloading is in package units using mechanical equipment; however, the pipe can be unloaded individually by hand. Mechanical equipment shall be operated so that it does not strike adjacent pipe and that pipe being moved does not strike anything.
- d. Unloading unpackaged PVC Pipe: PVC pipe may be unloaded and moved individually by hand if not packaged or if mechanical equipment is not available.
- e. Unloading Package Units: When unloading package units, the following instructions shall be carefully followed:
 - i. Remove restraints from the top unit loads;
 - ii. If there are boards across the top and down the sides of the load which are not part of pipe packaging, remove them;
 - iii. Use a fork lift with thin chisel forks, extend forks (or front end loader equipped with forks) to remove each top unit (one at a time) from the truck. Remove back units first. Do not run the forks too far under units as fork ends striking

adjacent units may cause damage. Insure forks are fully engaged;

- iv. If a fork lift is not available, a spreader bar with fabric straps which are capable of handling the load (with straps spaced approximately 8 feet apart and looped under the load) may be used. Cables may also be used if cushioned with rubber hose sleeves or other material to prevent abrasion of the pipe
- v. During the removal and handling, be sure that the units do not strike anything. Severe impact could cause damage, particularly during cold weather;
- vi. Do not handle units with individual chains or single cables, even if padded;
- vii. Do not attach cables to unit frames or banding for lifting;
- viii. Pipe package units shall be placed and stored on level ground;
- ix. Package units shall not be stacked more than eight feet high. Units shall be protected by dunnage;
- x. To unload lower units, repeat the above unloading process;
- xi. If unloading equipment is not available, pipe may be unloaded by removing individual pieces by hand. However, care shall be taken to insure that pipe is not dropped or damaged.

8) STORAGE REQUIREMENTS FOR PVC PIPE:

- a. PVC pipe shall be stored, if possible, at the job site in the unit packages provided by the manufacturer. Caution shall be exercised to avoid compression, damage or deformation to the bell ends of the pipe. Pipe shall be stored on level ground.
- b. If stored as individual pieces, pipe shall be arranged and supported so that there can be no compression, damage or deformation to the bell ends.
- c. When unit packages of PVC pipe are stacked, insure that the weight of the upper units does not cause deformation to the pipe in lower units.

- d. PVC pipe unit packages shall be supported by racks or dunnage to prevent damage to the bottom during storage. Supports shall be spaced to prevent pipe bending.
- e. When exposure to direct sunlight for an extended period is unavoidable, PVC pipe shall be covered with opaque material while permitting adequate air circulation above and around the pipe as required to prevent excessive heat accumulation.
- f. PVC pipe shall not be stored close to heat sources or hot objects such as heaters, boilers, steam lines, engine exhaust, etc.
- g. When unit packages of PVC pipe are stacked, insure that the height of the stack does not result in instability which could cause stack collapse, pipe damage or personnel injury.
- h. The interior as well as all sealing surfaces of pipe, fittings and other accessories shall be kept free from dirt and foreign matter.
- i. Gaskets shall be protected from exposure to heat, direct sunlight, ozone, oil, and grease.

9) HANDLING REQUIREMENTS FOR PVC PIPE:

- a. When using fork lifts or other handling equipment, prevent damage to PVC pipe.
- b. In handling PVC pipe, avoid impact blows, abrasion damage, and gouging or cutting by metal surfaces or rocks. Avoid stressing bell joints and damage of bevel ends.
- c. Pipe shall be lowered, not dropped, from trucks and into trenches.
- d. In preparation for pipe installation, placement of pipe (stringing) shall be as close to the trench as practical and on the opposite side from the excavated earth. Bell ends shall point in the direction of work progress.
- f. Pipe stringing shall not extend further than 100 feet beyond the installation.
- g. subfreezing temperatures, extra caution is required in handling PVC pipe to prevent impact damage.

10) EXTERNAL RESTRAINT OF PVC BELL AND SPIGOT JOINTS

PVC bell and spigot joints may be restrained by the use of the following external restraint harnesses only if specifically approved by the Spartanburg

Water Maintenance and Construction (M&C) or Engineering Departments. In all cases, the installation of these fixtures shall be performed as specified by the manufacturer, and shall be shown on the approved plans.

TABLE 5-2: PVC Pipe External Restraint Harness

Manufacturer	Model #	Notes
EBA Iron Sales, Inc.	Series 1500 Bell Restraint Harness	C-900 PVC
Ford	Uni-Flange Series 1390	DR-14 PVC Only
Sigma Corporation	Series PVP PV-Lok	PVC Only

C. HIGH DENSITY POLYETHYLENE (HDPE) PIPE

1) HDPE PIPE MANUFACTURE

HDPE pipe in Iron Pipe Size (IPS) and Ductile Iron Pipe Size (DIPS) 4” and above shall be manufactured to the requirements of ASTM F714 and AWWA C906, latest edition. Black PE materials used for the manufacture of polyethylene pipe and fittings shall be PE 3408 high density polyethylene meeting ASTM D3350 cell classification 345464C.

- a. Unless otherwise specified by the Design Engineer, HDPE pipe shall be Pressure Class 200 (DR-9) or greater wall thickness.
- b. The pipe is to be supplied in minimum 20 foot lengths with thermal butt fusion joints in accordance with ASTM D3261.

2) INSTALLATION

- a. Installation of HDPE pipe shall comply with the manufacturer’s recommendations.
- b. HDPE pipe shall be joined by the thermal butt-fusion method only, and the process shall comply in all respects with the pipe and equipment manufacturer’s recommendations.
- c. The equipment used to accomplish the thermal butt-fusion process shall be specifically manufactured for this purpose and shall incorporate a data-logger function which digitally records the conditions during the fusion process. The data-logger shall be capable of recording the conditions present during each individual butt-fusion operation, including time duration and temperature. A digital and hard copy of the data-logger record shall be provided to the District EFT for the work accomplished each day. These records shall be reviewed for compliance with the manufacturer’s recommendations. Any fusion which does not comply shall be rejected. The affected

joint and shall be cut out and replaced with an acceptable butt-fused joint.

- d. In installations where there will be a transition from HDPE to DIP or PVC slip-joint pipe, special restraint procedures are required to counteract the tendency of HDPE pipe to expand and contract due to changes in temperature. Refer CONSTRUCTION DETAIL No. 10.

2) INSPECTION

The Engineering Field Technician shall inspect the pipe for cracks and other defects immediately before installation. Any pipe containing defects which are discovered during the inspection or at any other time shall be removed from the job site.

D. FITTINGS

- 1) Fittings shall be ductile iron fittings manufactured in accordance with ANSI/AWWA C153/A21.53, latest revision. Where compact fittings are not available, fittings shall be full size iron fittings manufactured in accordance with ANSI/AWWA C110/A21.10 and ANSI/AWWA C111/A21.11, latest revisions. The working pressure rating shall be 350 psi.
- 2) Only MJ x MJ (for buried service) or Flange x Flange (for above-ground service) are approved. Push-on or other socket-type joints are not approved in any application, and proprietary restraining methods are not approved except as noted below.
- 3) Ductile iron shall be in accordance with ASTM A-536, latest revision, with minimum physical qualities of 70,000 psi tensile strength, 50,000 psi yield strength and 5% elongation.
- 5) Restraint of joints at MJ fittings shall be achieved through the installation of an approved restrainer gland with “auto-torque” twist-off heads. See below

TABLE 5-3: Approved Restrainer Glands for DIP and PVC with Ductile Iron Fittings

Manufacturer	Model #	Notes
EBAA Iron Sales, Inc.	MEGALUG Series 1100	DIP Only
EBAA Iron Sales, Inc.	MEGALUG Series 2000PV	PVC Only
Ford	Uni-Flange Series 1400	DIP Only
Ford	Uni-Flange Series 1500	PVC Only
Sigma Corporation	Series SLD One-Lok	DIP Only
Sigma Corporation	Series SLC One-Lok	PVC Only

NOTE: The use of a restrained joint at a fitting in no way insures the restraint of the pipe/fitting as a system. The Design Engineer shall be responsible for designing the force main piping system with proper consideration for all issues related to piping restraint, and the installation must be per the approved design.

- E. All Ductile Iron Fittings shall be factory-coated as follows. Field coating of DIP fittings is not authorized except to repair minor imperfections which may arise during handling:
- 1) Internal Coating shall be 40 mils Protecto-401
 - 2) External Coating shall be either one of the following:
 - a. Bituminous coat in accordance with ANSI/AWWA C104/A21.4.
 - b. Fusion-bonded epoxy coating shall be coated with in accordance with AWWA C-116.
- F. Sewer air/vacuum valves shall be SAAR Short Version D-025 as manufactured by A.R.I.

5-04 GENERAL FORCE MAIN INSTALLATION

(Refer to Section 6 for specific excavation and backfilling requirements).

- A. Pipe Handling: Handle pipe accessories so as to ensure delivery to the trench in sound, undamaged condition.
- 1) When using PVC material, keep pipe covered during storage to prevent damage by sunlight.
 - 2) Carry pipe into position - do not drag. Do not dump or drop any of the materials of this section into the trench.
 - 3) Lower pipe and accessories into trench by means of ropes, belt slings, or other equipment approved by the Engineer.
 - 4) Thoroughly clean interior of pipe and accessories before lowering pipe into trench. Keep clean during laying operations by plugging or other methods approved by the Engineer.
 - 5) Where any part of coating or lining is damaged, repair to the approval of the Engineer and at no additional cost to the Owner.
 - 6) Rubber Gaskets: Keep gaskets away from oil, grease, excessive heat and direct rays of the sun. Store in a cool dark place until just prior to time of installation.
 - 7) Before installation, inspect each piece of pipe and fitting for defects. Material

found to be defective before or after laying shall be replaced with sound material meeting the specified requirements, and without additional cost to the Owner.

B. Pipe Installation: Unless indicated otherwise herein, all pressure force main pipe shall be installed in the manner indicated in SECTION 6 of this document. Sewer lines in relation to water lines shall be located in accordance with Standards for Wastewater Facility Construction: R.61-67.300.A.14.

- 1) Pipelines intended to be straight shall be so laid.
- 2) Where vertical or horizontal alignment requires deflection from straight line or grade, such deflection shall not exceed maximum deflection recommended by the pipe manufacturer. If alignment requires deflection exceeding recommended limits, furnish special bends or a sufficient number of shorter lengths of pipe to provide angular deflections within the allowable limits.
- 3) Rest the full length of each section of pipe solidly on the pipe bed, with recesses excavated to accommodate bells, couplings and joints. Refer to CONSTRUCTION DETAILS No. 11 and 12.
- 4) Take up and relay pipe that has the grade or joint disturbed after laying.
- 5) Do not lay pipe in water, or when trench conditions are unsuitable for the work; keep water out of the trench until jointing is completed.
- 6) Cut pipe neatly and without damage to the pipe. Bevel edges.
- 7) Cut ends of Ductile Iron Pipe shall have the Protecto 401 coating repaired using the manufacturer's recommended procedures. Freshly-applied Protecto-401 coating shall be allowed to fully cure prior to the cut pipe being installed.
- 8) If mechanical joint pipe or fittings are used, a torque wrench will be required to tighten the "tee" bolts. Torque required for "tee" bolts used on pipe up to 24 inches shall be 90 lb. Bolts shall be tightened in proper sequence as recommended by the manufacturer.
- 9) Pipe shall be pushed into place by use of a bar or other means approved by the District.

C. Thrust restraint: All plugs, caps, tees, bends, and other items as may be indicated on the plans, shall be provided with reaction blocking, tie rods, or other approved restraining methods or as shown on the drawings for lines 2-inches in diameter and larger.

- 1) Concrete Blocking and Rodding:
 - a. Concrete used for blocking, collars and "Deadman" type thrust blocks

shall have a compressive strength of 3,000 psi at 28 days. High early strength concrete shall be used.

- b. Concrete shall be poured to the dimensions shown on the plans and formed when directed by the Engineering Field Technician. The large side (backs) of the blocking shall bear against undisturbed, hard, solid earth. Blocking shall be poured to bear against the pipe or fitting and allow sufficient area for repair and the easy removal of nuts and bolts. The pipe or fitting shall be wrapped with 8 mil polyethylene (according to AWWA C-105) for a suitable distance either side of the thrust block to prevent the concrete from bonding to the pipe, fitting, or fasteners. Refer to CONSTRUCTION DETAIL NO. 13.
- c. Backfilling on poured concrete will not be permitted on concrete for 24 hours after pouring, and no water will be permitted in mains for at least 24 hours after concrete blocking is poured.
- d. Metal Straps and rods shall be made of steel having a tensile strength of 95,000 psi. If required by the Engineer, the Contractor shall supply acceptable certification of tensile strength. All steel components, including rods, straps, nuts, bolts, couplings and clamps shall be coated with 17.5 mils of Thick and Quick Mastic, or equal. Contractor shall supply coating and coat all the tie rods, clamps and miscellaneous steel used for anchoring purposes.
- e. Concrete Collars poured on the last joint of pipe in a dead end run, shall be poured around a thrust collar which shall be installed according to the manufacturer's recommendations (unless welded on, which must be done at the factory). This collar shall be installed on the pipe midway between the MJ bell and the spigot. Pipe manufacturer's shop drawings must be submitted for each size collar to be used indicating that the collar is designed to, at a minimum, restrain the force created by a 250 psi line pressure as listed in the table below. Field welding thrust collars will not be allowed. Refer to CONSTRUCTION DETAIL NO. 9

TABLE 5-4: Thrust forces created by 250PSI test pressure

Pipe Size Nominal Inch	Test Pressure (PSI)	Thrust (LBS)
4	250	3,140
6	250	7,065
8	250	12,560
10	250	19,625
12	250	28,260
14	250	38,465
16	250	50,240
18	250	63,585
20	250	78,500
24	250	113,040
28	250	153,860
30	250	176,625
32	250	200,960
36	250	254,340
40	250	314,000
44	250	379,940
48	250	452,160

- 2) Certain applications require special thrust restraint procedures and designs which should be submitted to the Spartanburg Water Engineering Department for review.

D. Restrained Joint Pipe:

Restrained joint piping materials shall meet the requirements stated in Section 5-03 A, DUCTILE IRON PIPE and 5-03 D FITTINGS, and shall be as those shown on the shop drawings submitted by the Contractor and approved by the Engineer.

E. Tracer wire and warning tape installation:

- 1) General: Wherever PVC or HDPE pressure pipe is installed, tracer wire and warning tape shall be installed to facilitate future location of the force main.
- 2) Materials:
 - a. Tracer wire shall be 14 gauge solid copper wire. Wire shall be continuous.
 - b. Warning tape shall be brightly colored non-biodegradable plastic ribbon. The words "Warning PVC Sewer Line" shall be printed continuously along the length of the ribbon in large letters.
 - c. Test boxes shall be 4-inch ID plastic with cast iron cover and collar.

3) INSTALLATION:

- a. Tracer wire shall be taped to the top of the pipe (“12-o’clock position”) using strips of duct tape or other suitable adhesive tape spaced a minimum of every 5 feet along the entire length of the pipe.
- b. Tracer wires shall begin and terminate in the test boxes. Test boxes shall be installed at each location as shown on the plans, spaced at intervals not to exceed 500 feet. Test boxes shall not be installed in streets or driveways.
- c. Tracer wire between boxes shall be continuous, unbroken lengths. The tracer wire shall not be installed in tension, but neither shall there be "coils" in the wire. The ends of the tracer wires shall be installed in the test boxes. The length of each tracer wire in each box shall be long enough to extend no less than one foot and no greater than two feet above ground level and shall be attached to the terminal board.
- d. Breaks shall be repaired by splicing with a split-bolt clamp or pre-approved equal. Repairs by "twisting" the two ends together will not be accepted.
- e. Warning tape shall be buried in the backfill approximately one foot below grade, directly over the top of the PVC or HDPE pipeline. Tape shall be laid in continuous lengths. Any breaks or tears shall be repaired before proceeding with the backfilling operations. Refer to CONSTRUCTION DETAIL NO. 11.

- 4) TESTING: After construction and backfilling is complete, but before final inspection, the District’s Engineering Field Technician will test the tracer wire with standard District locating equipment. If the Engineering Field Technician determines that the tracer is not operating properly, the Contractor shall locate and correct the problem. The pipelines will not be accepted and placed in operation until the tracer system is acceptable

F. Sewer air/vacuum valve:

- 1) Air/vacuum valves shall be installed at high points in the force main and/or as designated by the Engineer. The air/vacuum valves shall be designed specifically for the flows and operating pressures of the particular system and shall be SAAR Short Version D-025 as manufactured by A.R.I. Inc.
- 2) An inlet isolation gate valve (Type 316 stainless steel) shall be provided. All connection piping external to the air release valve shall be Schedule 40 T-316 SS.

- 3) Air/vacuum valves shall be enclosed in a five-foot diameter precast manhole with a flat slab top as a minimum standard. Refer to CONSTRUCTION DETAIL No. 14.
- 4) Submittals on air/vacuum valves shall be sent to the District's Engineering Department for approval before ordering.

SECTION 6

TRENCH EXCAVATION AND BACKFILL

6-01 SCOPE:

Work consists of all necessary trench excavation and backfill work as shown on the plans and as specified herein.

6-02 GENERAL:

Trench excavation shall be confined to the construction area as shown on the plans, and shall be done in an approved manner with proper equipment. Excavation and backfilling shall be suspended during rain and inclement weather, or when unsatisfactory field conditions are encountered, unless otherwise directed by the Engineer. At all times during construction, Contractor shall maintain proper drainage in the construction area, and shall take all measures necessary for erosion and sediment control.

A. Location in Relation to Water Mains: Sewer lines in relation to water lines shall be located in accordance with Standards for Wastewater Facility Construction: R.61-67.300.A.14. When sewers are proposed adjacent to any existing or proposed potable water supply facility, the following requirements apply:

- 1) Potable Water Supply Interconnections. There shall be no physical connections between a public or private potable water supply system and a sewer, or appurtenance thereto, which may permit the passage of any sewage or polluted water into the potable supply. No potable water pipe shall pass through or come into contact with any part of a sewer manhole.
- 2) Horizontal and Vertical Separation from Potable Water Mains. Sewers shall be laid at least 10 feet horizontally from any existing or proposed potable water main. The distance shall be measured edge to edge. In cases where it is not practical to maintain a 10 foot separation, approval for a deviation must be obtained from SCDHEC. This request must be supported by data from the design engineer. Such deviation may allow installation of the sewer closer to a potable water main, provided that the potable water main is in a separate trench or on an undisturbed earth shelf located on one side of the sewer and at an elevation so the bottom of the potable water main is at least 18" above the top of the sewer.
- 3) Crossings. Sewers crossing potable water mains shall be laid to provide a minimum vertical separation of 18" between the outside of the potable water main and the outside of the sewer. This shall be the case where the potable water main is either above or below the sewer. Whenever possible, the potable water main shall be located above the sewer main. Where a new sewer line

crosses a new potable water main, a full length of ductile iron pipe shall be used for both the sewer line and potable water main, and the crossing shall be arranged so that the joints of each line shall be as far as possible from the point of crossing and each other. Where a potable water main crosses under a sewer, adequate structural support shall be provided for the sewer line to prevent damage to the potable water main while maintaining line and grade.

Refer to CONSTRUCTION DETAIL No. 15

- B. Existing Utilities: The Contractor shall be solely responsible for locating and verifying the location of all existing utilities. The Contractor shall take every precaution to protect existing utilities from damage during construction operations. If damage occurs, the utility involved shall be promptly contacted and repairs made at their direction and at the Contractor's expense. The work shall meet the approval of the utility involved. If the respective utility desires to make repairs with its own forces, the Contractor shall bear all the expenses of the work.
- 1) When interruptions of existing utilities occur, temporary service shall be provided as directed and approved by the respective utility involved.
 - 2) Notification of intent to excavate:
 - a) South Carolina Underground Utility Damage Prevention Act (S.C. Code Ann., 58-35-10, CT-SEQ, Supp. 1978) requires persons to ascertain the location of underground public utility property prior to excavation or demolition in certain situations. The Act also requires such persons to give timely notice of intent to excavate or demolish prior to commencing such operations. Failure to comply could subject the violator to a civil penalty for each violation of the Act.
 - b) Notification of intent to excavate may be given by calling this toll free number: "811".
 - 3) If existing utilities are found to conflict with the permanent facilities being constructed under this Section, immediately notify the Engineer and secure his instructions.
 - 4) Do not proceed with permanent relocation of utilities until verbal instructions are received from the Engineer.

6-03 TRENCH EXCAVATION:

- A. Trenches for pipe shall be excavated along the lines designated by the Engineer and to the depths necessary for laying sewers to the required grades. The cover over PVC pipe shall not be less than 3 feet. Where the cover is less than 3 feet, that section shall be ductile iron pipe.

- 1) Do not excavate trench more than 200 feet ahead of pipe laying, unless permitted by the Engineer.
- 2) Where trenching occurs in existing lawns, and seeding is not an option, remove turf in sections with appropriate turf cutting equipment and keep damp. Replace turf upon completion of the backfilling.
- 3) Where trenching takes place in existing concrete or asphalt pavement, the pavement shall be saw cut a width 2 feet wider than the top width of the trench, unless otherwise noted on the drawings. Ragged edges of pavement shall be recut as required prior to paving to form a straight and uniform alignment.
- 4) Sides of trenches shall be kept as nearly vertical as possible. Maximum trench width up to a level 24 inches above the top of the pipe shall be as shown on the plans.
- 5) Water which is found in or accumulates in trenches shall be pumped, bailed or otherwise removed. All machinery required for pumping or bailing shall be furnished by the Contractor. Trenches shall be kept free of water while pipe is being laid. Disposal of water after removal shall be satisfactory to the Engineer. There will be no disposal of water into existing sewer.

6-04 CLASSIFICATION OF EXCAVATION:

All excavation shall be unclassified, except as otherwise specified below.

A. Classified Excavation: This item covers the excavation of solid rock for pipelines and structures, disposal of excavated rock, and backfilling of the excavation to the level of the original ground line. Work shall include all labor, materials, equipment and permits required for excavation of rock.

- 1) Classified excavation shall be material which cannot be removed by means other than blasting or with air hammer. Material which can be removed by ripping shall not be considered "classified excavation."
- 2) Where rock is encountered at grade on pipelines, the trench shall be excavated to a depth as shown in the improved ditch bedding details and the pipe bedded in angular material as specified in SECTION 6-05 A. below. Rock excavation in pipe trenches shall be removed 8 inches beyond each side of the pipe outside diameter and 6 inches below the outside bottom of the pipe. Payment for rock will be at the unit price stated in the bid.
- 3) Contractor shall give the Engineer ample notice so that he or the District's Engineering Field Technician (EFT) may be on hand to measure the rock as it is excavated and before any backfilling has taken place.

- B. Blasting: All blasting, where required, shall be done under the personal supervision of a licensed individual thoroughly skilled in this class of work. All necessary measures to protect life and property shall be taken. Where in close proximity to buildings, transmission lines, telephone lines or other facilities, timber mats or other means of preventing damage from flying debris shall be used. Ample and suitable signals shall be given in proximity to the work before each blast, and flagmen shall be placed on all roads beyond the danger zone in every direction to warn traffic. Contractor shall be responsible for all damage resulting from blasting. The Blasting Permit Number shall be given to the District's EFT prior to blasting.

6-05 BEDDING OF PIPE:

- A. Pipe bedding material for PVC pipe shall be angular material in a general size range of 1/4-inch to 3/4-inch, at a minimum depth of 4 inches below bottom of pipe and to the depth of 6 inches where classified excavation is necessary.
- 1) Select material for backfill shall be suitable material from the excavation free of large stones, hard lumps, debris and other objectionable material. If select material is not available from the excavation, it shall be hauled to the site at Contractor's expense.
 - 2) Angular material shall be crushed stone or gravel conforming to ASTM D448, either Size No. 67 or Size No. 57.
 - 3) All trenches shall be excavated below the established subgrade as required to provide for preparation of trench bottoms in strict accordance with the improved ditch bedding details as shown. Stone bedding shall be so shaped that the load is supported throughout the entire length of the pipe barrel, and not at the pipe bells. Bell holes shall be dug to relieve bells of the load and to provide for completion of joints.
 - 4) Pipe bedding for ductile iron pipe shall be Class "D" or Class "C" as required by conditions or designated on plans.
 - 5) Class "B" bedding shall be required where:
 - (a) PVC pipe is used. Bedding shall extend a minimum of 4 inches below pipe and up to the springline of pipe. Where rock is encountered, bedding shall extend a minimum of 6 inches below pipe. Angular material shall be as specified in Section 6-05 A.2) above.
 - (b) Pipe depth exceeds 18 feet.
 - (c) Specifically noted on the plans or where directed by Engineer or EFT. Refer to CONSTRUCTION DETAIL No. 12

6-06 BACKFILLING OF TRENCHES:

Backfilling of trenches shall progress as rapidly as pipe-laying will permit.

- A. Backfill around the pipe and above the top of the pipe to a height of at least 12 inches above the top of the pipe shall be placed in layers not more than 6 inches thick. Only select material or angular material (where required) shall be used for this portion of backfill. As fast as the material is placed, it shall be cut under the haunches of the pipe with a shovel and thoroughly compacted with light tamps for the full width of the trench to provide support for the bottom and sides of the pipe. Backfilling shall be carried up evenly on both sides in 6-inch lifts to 12 inches above the pipe.
- B. Trench backfilling shall be deposited in level lifts, free of objectionable material and boulders and thoroughly compacted. No rock shall be placed in backfill that cannot be easily removed by hand. Compaction shall be such as to prevent future settlement and shall be done by acceptable means, approved by the Engineer.
- 1) Compaction will be accomplished by the use of a mechanical hand tamp or "sheepsfoot" trench roller. Where a mechanical hand tamp is used, lifts shall be placed in a maximum of 12-inch layers for 95% compaction and the range from 18-24 inch layers for 90% compaction. Where a sheepsfoot roller is used, lifts shall be placed in a maximum of 18-inch layers for 95% compaction and 18-24 inch layers for 90% compaction. Either method will require four passes up and down the trench line on either side of the pipe (one pass will be defined as one run up the trench and back down again).
 - 2) A hydro tamp may be used for compaction for the final two feet of backfill provided there is a minimum of seven feet of cover over the pipe.
 - 3) Rolling with rubber tired vehicles or track type equipment will not be allowed.
 - 4) Compaction shall be at least 90% of maximum as established by ASTM D698 (Standard Proctor); except that under pavement, compaction shall be at least 95% of maximum per ASTM D698.
- C. Under pavement, the top of the trench shall be filled with an aggregate base as specified in SECTION 9-03 C.
- 1) Tamp each layer to a density equivalent of not less than 95% of ASTM D698 Proctor Curve (Standard Proctor).
 - 2) Provide additional compaction by leaving the backfilled trench open to traffic while maintaining the surface with crushed stone.
 - 3) Refill any settlement with crushed stone and continue such maintenance until

replacement of pavement is authorized by the Engineer or EFT.

- D. Contractor shall be responsible for final subsidence of all trenches, and shall leave trenches flush with the original ground after all settlement has taken place. Any settlement of backfill below finish grade shall be promptly corrected. Trenches shall be protected against scour due to surface drainage.
- E. Backfill around manholes shall, in general, conform to the requirements for backfilling trenches, except that no backfill shall be placed around manholes until all mortar has properly set.
- F. Backfill may be subject to a compaction test by an independent laboratory selected by the Engineer or the District. If compaction fails the test, Contractor shall remove and replace backfill to the satisfaction of the Engineer and the District, and shall also pay for the cost of the test.

SECTION 7

SEWER SERVICE CONNECTIONS

7-01 SCOPE:

This section covers the requirements for the construction of service connections to District owned lines.

7-02 DESIGN CRITERIA:

Service connections shall be installed at the locations designated by the District and in conformity to the same ditching and bedding detail as used on the main sewer line construction.

- A. The maximum diameter of service connections to main sewer lines shall be 4”;
- B. Service lines larger than 4” shall be connected to manholes. Refer to CONSTRUCTION DETAIL No. 16

7-03 GENERAL MATERIALS:

- A. Wyes shall be 8-inch, 10-inch, 12-inch, etc., by 4 inches of the same material as the main line pipe and shall have the same type gasketed connections. Tees will not be allowed.
- B. Bends shall be standard 4-inch, 11.25° (1/8) pipe bends. Bends and joints shall be as specified for service pipe.
- C. Service Pipe installed as part of main sewer line construction shall be standard 4-inch service pipe. PVC service pipe shall be 4-inch SDR 35 pipe which complies with the same requirements as the main sewer, conforming to ASTM D3034, F-794 or F-949 with gasketed joints and all required markings consistent with main line material.
- D. Service Pipe installed by a plumber in conjunction with a main line tap, existing stub out or manhole shall be either 4-inch ductile iron, SCH 40 PVC, or PVC pipe consistent with the existing stub out pipe (see section 7-03 C. above).
- E. Main line tapping saddles shall be Predco Fastfit Sewer Tap Saddle with Stabilizing Bands, ROMAC CB Sewer Saddle or approved equal.

7-04 INSTALLATION OF SERVICE LINES ON NEW SEWER PROJECTS:

Service connections shall be properly installed at the required locations. All wyes, bends, service pipe and other appurtenances shall be provided as required for each connection. All joints shall be installed so as to provide watertight connections.

- A. Catalog cuts and related data for all material shall be submitted to the Engineering Field Technician and the Engineer for review.
- B. Wye joints shall be installed as directed, with the branch turned to the proper direction, or as shown on the plans. Wyes shall be firmly supported by methods and materials used for bedding of main line pipe. Branch of wyes shall be installed at an angle 45° to the springline unless grade requirement dictate otherwise
- C. Bends for service lines shall be placed in the wyes where directed by the Engineer, or where necessary for proper alignment.
- D. When installed during sewer line construction, service pipe shall be installed to the proper line and grade from the sewer line to the property line at a grade of not less than 1/4" per foot. Backfilling and bedding procedures shall be as for sewer line mains. Water tight plugs shall be placed in the end of service line stubs. Plugs shall be as recommended by the pipe manufacturer and shall be installed in accordance with the manufacturer's recommendation. Refer to CONSTRUCTION DETAIL No. 17. Suitable markers shall be installed at the ends of service line stubs for above ground location. A suitable marker shall include a section of pipe of the same material as service line extended one to two feet above ground surface.
 - 1) Service line stub locations at the property line shall be recorded by the Contractor and furnished to the Engineer to be included on the as-built drawings.
 - 2) Service line locations shall be referenced to the station location of the main at the point the service line intersects the sewer main. In the event a service line is not installed at a 90° angle to the sewer main, the station of the service line at the property line shall be referenced to the main line station. The information shall also include the perpendicular distance from the center of the sewer main to the end of the service line and the depth of the sewer line.
 - 3) The service line location data referenced in item 2) above shall be included on the As-Built drawings in a Table of Sanitary Sewer Tap Locations as shown in CONSTRUCTION DETAIL No. 18.

7-05 SERVICE CONNECTIONS TO EXISTING LINES:

A. Materials:

- 1) Minimum pipe size connection to either existing sewer main lines or manholes shall be 4 inches.
- 2) Taps into existing sewer main lines shall use a gasketed fitting in conjunction with a "Predco Fastfit" sewer tap saddle or ROMAC CB Sewer Saddle (or approved equal). Saddles shall be mounted on pipe according to manufacturer's recommendations. Refer to CONSTRUCTION DETAIL No. 19

- 3) Taps directly into manholes shall be made by coring the manhole wall and installing the proper size manhole boot. Refer to CONSTRUCTION DETAIL No. 16.

B. Installation:

- 1) Taps will not be made prior to applicable fees being paid and a sewer connection permit being obtained from the Spartanburg Water New Connections Department
- 2) The main line will be tapped only when no service line stub is available. In the event the service line stub cannot be located by the District personnel, the plumber/ contractor will be allowed to tap the line. Service line shall be installed at an angle of 45° to the springline unless grade requirements dictate otherwise.
- 3) Ties to Existing Service Line Stubs:
 - a) Connection shall be made with the proper watertight connector suitable for the application.
 - b) Connection shall remain visible until inspection by the District Engineering Field Technician (EFT).
 - c) Backfill shall be carefully placed and tamped around the connection as to prevent any settlement or movement.
- 4) Taps to Sewer Main Lines:
 - a) Tap saddles shall be installed in accordance with manufacturer's recommendations.
 - b) Holes for saddles shall be 4.5 inches in diameter and shall be made by mechanical hole cutters or by keyhole saw or saber saw only. "Hammer Taps" are not approved. Holes shall be laid out with a template at an angle of 45° to the vertical (unless grade requirements dictate otherwise) and shall be deburred and carefully beveled to provide a smooth hole shaped to conform to the fitting. Care shall be taken to prevent any foreign material from entering the cut-in pipe opening. Any material or debris that does enter the line shall be removed.
 - c) Where applicable, saddle and pipe mating surfaces shall be wiped clean and dry. Epoxy cement shall be used in cementing in accordance with the cement manufacturer's recommendations and ASTM D2855.
 - d) Service line shall be connected to the Predco tap saddle or ROMAC

CD saddle by means of a fixture specified by the tap saddle manufacturer.

- e) Spartanburg Sanitary Sewer District tap inspection shall be conducted after hole is cut, **BUT BEFORE CONNECTION IS MADE UP.**
- f) If integrity of sewer main is breached during tap installation:
 - i. Where the installation of the tap causes visible cracks or splits in the clay sewer line, the sewer main line will be encased in concrete for the full length of the cracked pipe.
 - ii. Where the installation of the tap causes visible cracks or splits in the PVC sewer line, the cracked sewer line shall be cut out and replaced with a section of the appropriate size SDR-35 PVC using gasketed, PVC, bell x bell or bell x spigot couplings (“Harco Coupling”) or approved equal watertight coupling suitable for the application. The EFT shall determine the length of damaged sewer main to be replaced to remove all damaged material. The EFT, at their discretion, may approve “Fernco” or similar rubber, strapped, couplings in making PVC or DIP main-sewer pipe connections.
 - iii. Any sewer line damaged during the installation of a tap, shall be repaired at no cost to the District.
- g) In the event water is entering into the ditch, the contractor/plumber shall pump the ditch as dry as necessary to make the complete connection visible at the time of inspection.
- h) Backfill shall be carefully placed and tamped around the connection so as to prevent any settlement or movement. Where a cracked pipe is encased in concrete, backfilling shall not commence until the encasement has hardened.

5) Taps to Manholes:

- a) Service line must enter manhole at angle no less than 90° to the direction of flow.
- b) For manholes less than 12 feet in depth:
 - i. Plumber/contractor shall core drill the manhole wall directly above manhole table to a diameter specified by the manhole boot manufacturer. If the slope of table is less than 2 1/2" per foot, the invert of service line shall enter manhole 6" above table, and a suitable service invert formed on the table. Refer to CONSTRUCTION DETAIL NO. 16.

- ii. Pipe connections shall be made by a flexible synthetic rubber boot mechanically clamped to the manhole and to the pipe to provide a watertight seal and designed to accommodate pipe movement up to 2 inches radially or 22 degrees angularly in any direction. The synthetic rubber boot shall have a minimum wall thickness of 3/8 inch. The synthetic rubber material shall conform to ASTM C-923 (latest version). Bands, clamps and other metal accessories shall be of Series 304 stainless steel. Approved manhole boots shall be Kor-N-Seal as manufactured by NPC or PSX Direct Drive as manufactured by Press-Seal. Refer to CONSTRUCTION DETAIL NO. 5
 - iii. The void area inside the manhole boot shall be filled with non-shrink grout such as "Preco Plug," or approved equivalent, and walls shall be trowelled smooth.
 - iv. A curved trough shall be formed on/in manhole table to direct flow into the main invert. If the service enters below the table, then table must be removed and a new trough formed.
 - v. Spartanburg Sanitary Sewer District tap inspection shall be held before backfilling commences. Work must be visible and dewatered during inspection.
 - vi. Backfill shall be carefully placed and tamped around the connection so as to prevent any settlement or movement and shall commence only after non-shrink grout has sufficiently hardened.
- c) For manholes greater than 13.5 feet in depth, an inside drop may be installed. Inside drops on existing (4' ID) manholes are allowed for 6" services; however, it is critical that the drop be constructed so as minimize the intrusion into the manhole. Also, no restriction of the normal use of the manhole steps is allowed. Refer to CONSTRUCTION DETAIL NO. 7.
- i. Plumber/contractor shall core drill the manhole wall a minimum of four feet below ground surface. If four feet cannot be obtained, notify the Spartanburg Sanitary Sewer District Engineering Department before proceeding.
 - ii. A manhole boot shall be installed as given in paragraph 3) b) ii. above.
 - iii. Service pipe shall be inserted through the manhole wall.
 - iv. A tee shall be placed on pipe with run horizontal for clean out,

and a PVC plug, with a section removed, inserted in the run of the tee. The half-plug will create a dam prevent high flows from overrunning the drop, but will permit the entry of rodding tools for cleaning.

- v. The drop pipe shall extend to the manhole table and a 45° bend shall be installed on the end. The 45° bend shall be rotated toward the direction of water flow in the invert.
- vi. Inside piping shall be secured to the manhole wall by means a stainless steel strap spaced every 4 vertical feet and securely anchored to manhole wall. The space between the entering pipe and the manhole opening shall be sealed with a non-shrink grout.
- vi. A curved trough shall be formed on/in manhole table to direct flow into main invert. The trough shall extend beyond the opening of the 45° bend to its curvature or change in direction.
- vii. The void area inside the manhole boot shall be filled with non-shrink grout such as "Preco Plug," or approved equivalent, and the walls shall be trowelled smooth.
- viii. Spartanburg Sanitary Sewer District tap inspection shall be held before backfilling commences. Work must be visible and dewatered.
- ix. Backfill shall be carefully placed and tamped around the connection so as to prevent any settlement or movement only after non-shrink grout has sufficiently hardened.
- x. The Spartanburg Sanitary Sewer District reserves the right to deny the installation of an inside drop for any reason. If an inside drop is planned, the plumber should contact the Spartanburg Sanitary Sewer District Engineering Department to confirm approval prior to proceeding with the work.

C. Inspection of Taps to Existing Lines:

- 1) Plumber shall contact the New Connections Department (585-5629 or 585-2033) approximately eight hours before tap inspection will be needed. Tap to main lines shall remain **UNCONNECTED AND DEWATERED** until the tap has been approved by District EFT.
- 2) In the event a road or street must be cut in order to make the connection, the plumber will obtain a road/street cut permit and have it at the job site at the time of the inspection. If the road/street cut permit is not available at this

time, the tap will not be inspected.

- 3) Service lines over 100 feet in length will be tested for infiltration/exfiltration by the District-approved method covered in SECTION 12.
- 4) If tap fails inspection, the connection will be corrected at no expense to the District. District inspection is required after correction and tap shall remain uncovered and dewatered until tap passes inspection.
- 5) Failed Inspections:
 - a) Any tap which fails inspection shall be corrected within 5 working days, after the date on which the first inspection was performed;
 - b) The City or the County Building Inspection Department(s) shall be notified of any tap which is not corrected and successfully re-inspected within this time frame.

SECTION 8

BORING AND AERIAL CROSSINGS

8-01 SCOPE

This section contains the current specifications for the installation of pipe by various methods other than conventional “open cut” including the following:

- Boring (including specialized boring methods other than Directional Drilling)
- Horizontal Directional Drilling (HDD)
- Pipe supported on piers
- Pipe attached to bridges (or structures which have an intended purpose other than supporting the pipe).

The conventional “open cut” method of pipe installation is covered in SECTIONS 4, 5 and 6 of these Specifications. However, plans which incorporate alternative pipe installation methods, which are the subject of this section, must be prepared by engineers specifically trained and experienced in the particular method used. The specifications listed below are not intended to replace or be used as a substitute for the detailed design by a licensed engineer.

The review of plans by the Spartanburg Sanitary Sewer District Engineering Department will only serve to insure compliance with SCDHEC and District specifications. The design and use of alternative installation methods include various risks which may not exist with other methods; the Design Engineer and Contractor must accept full responsibility for the liabilities associated with these alternative methods. In situations where substantial risks exist, the District reserves the right to require additional liability insurance coverage, and/or extended warranties, beyond that noted in SECTION 1 and SECTION 14 of these Specifications.

8-02 BORING (INCLUDING JACK AND BORE, IMPACT MOLE, CLOSED-FACE BORE, MICRO-TUNNELING and others)

Where shown on the approved plans, pipe shall be installed under highways, railroads, or other obstacles by boring. The Contractor shall furnish all labor and materials necessary to complete the bore, install steel casing if required, and install carrier pipe per the approved plans.

- A. All bores under railroads shall be performed as required by railroad specifications. The Design Engineer shall be responsible for compliance with all railroad related permitting and design requirements.
- B. Service line bores under highways may be made without encasement unless otherwise noted on the plans.

C. If steel casing is required, unless otherwise noted on plans, encasement up to and including 48-inches in diameter shall be installed by boring and jacking (either augur or closed-face). Larger encasement shall be by tunneling. Refer to CONSTRUCTION DETAIL NO. 20.

D. GENERAL REQUIREMENTS:

- 1) Authorities: All aspects of crossing construction shall conform to the requirements of the South Carolina Department of Transportation, the applicable railroad or other agency having jurisdiction.
- 2) Insurance: It shall be the responsibility of the Contractor and/or his subcontractor to comply with all insurance requirements of the highway or railroad work within their right-of-way if the limits are higher than the limits of the insurance requirements of this contract.
- 3) Inspection: Crossing construction operations shall be subject to inspection by the Owner's representative and by the highway or railroad representative, who shall have full authority to stop work if, in his opinion, it would cause damage to the roadway or railway section, endanger traffic or endanger life.
- 4) Prior to beginning work, the Contractor shall submit to the Engineer a work plan detailing the procedure and schedule to be used to execute the project. The work plan shall include as a minimum:
 - a. a description of all equipment to be used;
 - b. a list of personnel and their qualifications and
 - c. experience (including back-up personnel in the event that an individual is unavailable);
 - d. list of subcontractors;
 - e. a schedule of work activity;
 - f. a safety plan (including MSDS of any potentially hazardous substances to be used);
 - g. traffic control plan (if applicable);
 - h. an environmental protection plan and contingency plans for possible problems.

The work plan shall be comprehensive, realistic and based on actual working conditions for this particular project. Plan shall document the thoughtful planning required to successfully complete the project.

E. ADDITIONAL REQUIREMENTS

- 1) Contractor shall comply with all requirements of the highway or railroad relating to temporary work, inspection, watchmen, flagmen, traffic barriers, protection of personnel and property, work restrictions, work scheduling, insurance and such other requirements. The Contractor shall pay for all costs associated with meeting these requirements, except as otherwise specified.
- 6) If steel casing is required, it shall be within the limits of the highway or railway right-of-way and shall be installed to the proper line and grade; no open excavation will be allowed within the limits of the steel casing without the Engineer's approval. The steel casing shall be furnished and installed in accordance with additional requirements specified herein.
- 7) All work shall be completed to the full satisfaction of the highway or railroad engineer, or his authorized representative
- 4) For work on railroad right-of-way, the Contractor shall notify the railroad division Superintendent at least 72 hours prior to entering railroad right-of-way to begin construction.

F. INSTALLATION BY THE BORING METHOD: Installation of the sewer main and, the steel pipe casing, where required, shall be by the dry boring method at locations shown on the Drawings. Installation shall include all related work and services such as mobilization, construction and maintenance of work pits, R/W maintenance and restoration, traffic maintenance, excavation, dewatering, sheeting, shoring, bracing, bulkhead, clean up, and move out. Installation of steel casing shall be in accordance with the applicable regulations of the South Carolina Department Transportation, the specific Railroad company; the Detail Drawings and these Specifications. All excavations for pit and bore shall be unclassified. Refer to CONSTRUCTION DETAIL No. 20

- 1) Boring Pit:
 - a. The boring pit shall be solid sheeted, braced, shored, and dewatered as necessary to provide a safe operation;
 - b. The limits of the bore pit work space shall be contained on public right-of-way unless prior construction or permanent easements have been secured;
 - c. Provide protection to other utilities and roadways;
 - d. The Contractor shall take all precautions, and shall comply with all requirements as may be necessary to protect private or public property;

- 2) Line and Grade: The Contractor shall set the boring rig so that the installation of the sewer pipe (and the casing pipe if required) conform accurately to the grades and alignment on the approved Drawings.
- 3) Boring:
 - a. Where encasement is required, the sewer main diameter and steel casing diameter shall be as noted on the plans. The hole shall be bored and encased through the soil by a cutting head on a continuous auger mounted inside the steel casing.
 - b. The boring of the hole and installation of the steel casing shall be simultaneous. Lengths of casing shall be fully welded to the preceding section in accordance with American Welding Society recommended procedures. The Contractor shall bear the cost of any corrective action required to meet line and grade requirements shown on the plans.
 - c. The distance to which excavation is carried ahead of the casing shall be not more than is absolutely necessary for installation purposes, and will be subject to approval of the Engineer. The work shall be performed so that no voids occur in the earth surrounding the casing and so that ground settlement adjacent to and within the limits of the pipeline crossing is eliminated.
 - d. If voids occur or are encountered outside the pipe, the Contractor shall stop the work and contact the agency having jurisdiction (SCDOT, Spartanburg County, etc.). The Contractor shall correct this condition using the method required by the agency. One method of correcting this condition is grout injection as follows:
 - i. holes shall be drilled at 10-foot centers to near the top of the steel casing;
 - ii. the voids filled with a 1:3 Portland cement grout at sufficient pressure to fill voids and prevent embankment settlement.
 - iii. If disruption of traffic will occur during the work, the Contractor shall obtain an approved Traffic Control Plan prior to commencing the work. All traffic control requirements shall be the responsibility of the Contractor.
 - e. If it becomes necessary to abandon an incomplete or unacceptable bore, the abandoned encasement shall be capped and filled completely with 1:3 Portland cement grout. Abandonment procedures shall be completed prior to moving to another boring location. All costs in connection with an

abandoned bore, including the construction cost and capping and filling costs, shall be at the Contractor's expense.

- 4) Steel casing installed by boring and jacking shall be welded steel pipe conforming to ASTM A139, Grade B, and shall be of the sizes shown on the plans. Pipe shall be bituminous coated on the outside. Casing size and minimum wall thickness shall be as follows:

Table: 8-1: Steel casing diameter and thickness according to size of carrier pipe.

Carrier Pipe Diameter (inches, nominal)	Required Casing Diameter (inches, nominal)	Casing Thickness (inch)
4"	8	.0188 (3/16)
6"	12	.0188 (3/16)
8	16	0.250 (1/4)
10	18	0.250 (1/4)
12	20	0.281
14	22	0.312
16	24	0.344
20	28	0.406
24	32	0.438
30	38	0.5
36	44	0.5
48	56	0.75
60	68	0.75
Greater than 60	Per Design	Per Design

When steel casing is installed without protective coating or cathodic protection, the wall thickness shall be increased a minimum of 0.063 inch greater than the thickness shown above.

- 5) Boring without encasement shall be bored through the soil and the pipe pushed through the bore hole. The diameter of the bore shall be no larger than 4-inches greater than the diameter of the bell of the pipe.
- F. Casing Spacers: All carrier pipe installed inside encasement shall be supported by spacers ("spiders") as called for on the plans. Spacers shall be fabricated from quality ASTM A36/A structural steel with continuous meg welds at each joint. The flanges for the two-piece spacer supports shall be formed with half bands. The legs shall be welded to the bands and the skids welded to the legs. After fabrication, the spacers shall be coated with bituminous dip. Grade 5 bolts with nylon locking nuts shall be used to secure the spacer supports to the carrier pipe. Spacers shall be manufactured by Spider Manufacturing, Inc., Cascade, Inc., or other approved supplier. The casing spacers must be submitted to the

Spartanburg Sanitary Sewer District Engineering Department as part of the plan review.
Refer to CONSTRUCTION DETAIL NO.21.

8-03 HORIZONTAL DIRECTIONAL DRILLING (HDD)

- A. **SCOPE OF WORK** This section contains guidelines and specifications applicable to the installation of pipelines using horizontal directional drilling (HDD). It includes minimum requirements for design, materials and equipment used for the horizontal directional drilling for the substantially trenchless construction of pipelines. The section also includes materials, dimensions and other pertinent properties of pipe and required accessories. These properties provide minimum performance requirements for various components including joints.
- B. **SUBMITTALS:**
- 1) All items listed under paragraph 8-02 D. above shall be submitted for approval
 - 2) Specifications on material to be used shall be submitted to Engineer. The material shall include the pipe, fittings, drilling mud, drilling additives and any other item, which is to be an installed component of the project or used during construction.
 - 3) Historically, High Density Polyethylene Pipe (HDPE) was the only material used for HDD installation of sewer mains. However, during recent years, additional materials are being installed by HDD Contractors, including fusible PVC and restrained joint ductile iron. Alternate pipe materials, other than HDPE, will be considered on a case-by-case basis by the District. The use of alternate materials for HDD project shall be submitted to the Spartanburg Sanitary Sewer District Engineering Department for review and approval. The District makes no commitment regarding the future use of HDD as a pipe installation method, based on previous projects or assumed approvals.
- C. **GENERAL**
- 1) The bore path alignment and design for HDD shall be based on the Engineer's plans and other factors. Some factors which must be considered are the acceptable bend radius or maximum deflection capabilities of the joint (if jointed pipe is used)
 - 2) Prior to the start of drilling, reaming, and pipe placement operations, the Contractor shall properly locate and identify all existing utilities in proximity to the pipeline alignment. The Contractor shall confirm the alignment of all critical utilities, using vacuum excavation or other suitable "soft dig" excavation method, for further detailed confirmations as necessary.

D. EQUIPMENT AND EXPERTISE

- 1) The Contractor shall have equipment and expertise, appropriate for horizontal directional drilling installations. This includes the preparation and maintenance of the bore path using drilling fluids appropriate for the geology of the soils. The Contractor shall also have experience in safety and dependability installing, in similar geology, similar size and length of piping involved.
- 2) The directional drilling machine shall consist of a hydraulically powered system to rotate, push and pull hollow drill pipe into the ground at variable angles down to 8 degrees above horizontal, while delivering a pressurized fluid mixture to a guidable drill (bore) head. The machine shall have a capacity to adequately complete the drilling and piping installation. The machine shall be anchored to the ground to withstand the pulling, pushing and rotating pressure required to complete the crossing.
- 3) The hydraulic power system shall be self-contained with sufficient pressure and volume to power drilling operations. Hydraulic system shall be free of leaks. Rig shall have a system to monitor the maximum pull-back pressure during the pull-back operation. The rig shall be grounded during drilling and pull-back operations. There shall be a system to detect electrical current from the drill string and an audible alarm, which automatically sounds when an electrical current is detected.
- 4) The drill head shall be a steerable type and shall provide the necessary cutting surfaces and drilling fluid jets. Mud motors shall be adequate power to turn the required drilling tools.
- 5) The equipment shall incorporate a conventional electromagnetic sound walkover system or Magnetic Guidance System (MGS) probe or proven gyroscopic probe and interface shall be used to provide a continuous and accurate determination of the location of the drill head during the drilling operation. The guidance shall be capable of tracking at the maximum depth required and in any soil condition, including hard rock. It shall enable the driller to guide the drill head by providing immediate information to the tool face, azimuth (horizontal direction), and inclination (vertical direction). The guidance system shall be accurate to $\pm 2\%$ of the vertical depth of the borehole at sensing position at depths up to one hundred feet and accurate within 5 feet (1.5) meters horizontally.
- 6) The Guidance System shall be of a proven type and shall be setup and operated by personnel trained and experienced with this system. The Operator shall be aware of any geo-magnetic anomalies and shall consider such influences in the operation of the guidance system if using a magnetic system.

E. DRILLING FLUID (MUD) SYSTEM

- 1) A self-contained, closed, drilling fluid mixing system shall be of sufficient size to mix and deliver drilling fluid composed of bentonite clay, potable water and appropriate additives. Mixing system shall be able to molecularly shear individual bentonite particles from the dry powder to avoid clumping and ensure thorough mixing. The drilling fluid reservoir tank shall be a minimum of 500 gallons. Mixing system shall continually agitate the drilling fluid during drilling operations.
- 2) Additives to drilling fluid such as drill soap, polymers, etc. shall be “environmentally safe” and be approved for such usage. No diesel fuel shall be used.

F. OTHER EQUIPMENT

- 1) Pipe rollers shall be of sufficient size to fully support the weight of the pipe while being hydro-tested and during pull-back operations. Sufficient number of rollers shall be used to prevent excess sagging of pipe. Rollers shall be used as necessary to assist in pull back operations and in layout/jointing of piping.
- 2) Hydraulic or pneumatic pipe rammers may only be used if necessary and with the authorization of Design Engineer. Other devices or utility placement systems for providing horizontal thrust other than those previously defined in the preceding sections shall not be used unless approved by the Design Engineer prior to commencement of the work. Consideration for approval shall be made on an individual basis for each specified location. The proposed device or system shall be evaluated prior to approval or rejection on its potential ability to complete the utility placement satisfactorily without undue stoppage and to maintain line and grade within the tolerances prescribed by the particular conditions of the project.

G. GENERAL

- 1) The Engineering Field Technician must be notified 48 hours in advance of starting work. The directional bore shall not begin until the Engineering Field Technician (EFT) is present at the job site and agrees that proper preparations for the operation have been made. The approval of the EFT for beginning the installation shall in no way relieve the Contractor of the ultimate responsibility for the satisfactory completion of the work.
- 2) All personnel shall be fully trained in their respective duties as part of the directional drilling crew and in safety. Contractor must show job history and reference list of equal or greater size and length of piping involved. The Supervisor must have at least two years directional drilling experience. A competent and experienced supervisor representing the Drilling Contractor shall be present at all

times during the actual drilling operations. A responsible representative who is thoroughly familiar with the equipment and type work to be performed, must be in direct charge and control of the operation at all times.

- 3) Testing and acceptance of sewer lines installed by HDD shall be as indicated in SECTION 12 of these Specifications as applicable.

8-04 PIPE SUPPORTED ON PIERS

- A. **GENERAL:** This section addresses the situation in which the sewer line must cross natural or man-made terrain features, with the pipe exposed above-ground, rather than crossing underground. The guidelines below refer to sewer lines in the Spartanburg Sanitary Sewer District (hereinafter referred to as the "District") collection system, and may not apply to other aerial installations such as within treatment plants or other isolated facilities. The Engineer shall be responsible for all details associated with the design of pier-supported piping systems. All details related to a planned aerial crossing on piers shall be submitted the District's Engineering Department with the preliminary plan submittal package.
- B. **MATERIALS:**
 - 1) Ductile iron pipe shall be used for all aerial crossings, the required wall thickness shall be specified by the Engineer.
 - 2) The DIP joint configuration shall be as specified;
 - 3) Fittings and appurtenances shall be as specified;
 - 4) Long span pipe may be used to reduce the number of joints; this material shall be submitted to the District's Engineering Department for approval.
- C. **DESIGN CONSIDERATIONS**
 - 1) The carrying capacity of the supports themselves,
 - 2) The strength of the structure from which a pipe may be suspended
 - 3) Unusual or additional loads not in the scope of this section. Such loading may include seismic, frequency or resonance of vibrations, wind, water current, and other special design considerations.
 - 4) It is also necessary to ensure a minimum of lateral and vertical stability at the supports for aboveground piping. Deflected pipe joints can result in thrust forces of hydrostatic or hydrodynamic origin, and, if not laterally and vertically restrained, unbalanced forces may result in additional joint deflection and possible failure of the pipeline.

- 5) Thermal expansion of ductile iron pipelines supported above ground is not usually of concern in correctly designed and installed systems because of the nature of the push-on joint. A 120° F change in temperature results in expansion or contraction of a 20' length of ductile iron pipe of approximately 1/8". This is easily accommodated by correctly installed pipe and joints.
- 6) Occasionally, where support structures are expected to have significantly different behavior than the pipeline, special considerations for expansion, contraction, and supports may be necessary;
- 7) Supports should generally be positioned immediately behind the pipe bells. Supports should normally not be placed under spigots adjacent to bells, due to possible undesirable effects on joints.
- 8) Pipe supports should cradle the pipe in a saddle. This cradling, which should follow the contour of the pipe, minimizes stress concentrations at the supports. It is recommended that the saddle angle of the support be between 90° and 120°. Little or no benefit is gained by increasing the saddle angle more than 120°. With angles smaller than 90°, the maximum stress tends to increase rapidly with decreasing saddle angle.
- 9) Supports, piles, and/or foundations should be adequately designed from a structural and soil-engineering standpoint to safely handle any loads transferred from the pipe.
- 10) Refer to CONSTRUCTION DETAIL NO. 22. NOTE: The construction details provided in these Specifications are suggestions only and do not relieve the Design Engineer from the responsibility and obligation to consider all issues related to the proper design of all structures and systems and compliance with all applicable regulations and standards.

8-05 PIPE ATTACHED TO BRIDGES

- A. **APPROVALS:** Attachment of sewer lines to bridges or other structures must be approved by the agency with jurisdiction over the structure. It shall be the responsibility of the Design Engineer to obtain written authorization and approval as needed from all agencies including (but not limited to) the following:
 - 1) SCDOT
 - 2) The City of Spartanburg
 - 3) Spartanburg County.

- B. **GENERAL:** All pipe, fittings and appurtenances shall be assembled and joined in accordance with the instructions in this Section and manufacturer's recommendations and shall accurately conform to the dimensions established. Pipe hanger assemblies shall be the type and size indicated on the plans and shall meet the requirements stated on the plans and stated herein. The pipe hanger shall be either a yoke pipe roll or a clevis. All pipe fittings and appurtenances shall be adequately supported and anchored, protected from damage and freezing, and accessible for repair and replacement.
- 1) Steel Yoke Pipe Roll Hanger: If the hanger is to be a yoke pipe roll type, it shall be a Grinnell "adjustable steel yoke pipe roll," or approved equal. The yoke, roll rod and hex nuts shall be manufactured from carbon steel and the roll shall be cast iron. Each hanger shall have a maximum recommended load of not less than 1200 lbs.
 - 2) Pipe Hanger Clevis: If the pipe hanger is to be a clevis type, it shall be a Grinnell "adjustable clevis for cast iron pipe," or approved equal. The clevis shall be manufactured from carbon steel and shall have a maximum recommended load of not less than 1940 lbs.
 - 3) Rods: Rods shall be the diameter and length shown on the plans. Rods shall be carbon steel with a minimum yield strength of 60,000 psi. Rods shall be threaded to match the hanger hardware.
- C. **EXISTING BRIDGE:** Where a pipeline is to be installed on an existing bridge, it shall be supported by hangers attached to the bridge by anchors drilled and embedded in the bottom of the bridge deck as shown on the construction plans.
- 1) Concrete Anchors: Shall be the Hilti HVA Adhesive Anchor System or approved equal with 7/8-inch diameter and a minimum embedded depth of 6 5/8 inches. Tensile bond strength shall be 28,720 lbs minimum.
 - 2) Installation: During assembly, the vertical position of the hanger on the rod shall be adjusted to provide consistent clearance between the pipe and the bridge deck. The hanger rod nuts shall be tightened securely. Each completed hanger assembly shall be coated with 17.5 mils of Koppers Bitumastic 300-M, or equal.
- C. **NEW BRIDGE:** Where a pipeline is to be installed on a bridge which is being newly constructed, arrangements will be made by the District to have concrete inserts cast in place in the bottom of the bridge deck when it is being formed. The pipeline will be supported by hangers attached to these inserts as shown on the construction plans.
- 1) Concrete Inserts: Concrete inserts shall be the Grinnell "wedge type concrete insert," or approved equal. The inserts shall be manufactured from carbon steel and have a galvanized finish. The nut shall be iron. Maximum recommended load shall be not less than 1,200 lbs. Inserts shall be installed in place by nailing each

insert to the wooden form at the locations shown on the plans before the concrete is poured into the form. Two one foot lengths of 3/8-inch rebar shall be installed in the slots of each insert as shown on the plans and shall be cast in place with the inserts. After the bridge is poured, set and the forms removed, the knockout plate in each insert shall be removed with a screwdriver.

- 2) Installation: The wedge nut should be put on the rod before inserting into the concrete insert body. Insert the nut into the slot and turn rod so the elongated nut lies across the slot. Screw rod through nut until rod is firmly against the top of the recess.
- 3) After assembly of pipe, clevis and rod, the vertical position of the clevis on the rod shall be adjusted to provide consistent clearance between the pipe and the bridge deck. The hanger rod nuts shall be tightened securely. Each completed hanger assembly shall be coated with 17.5 mils of Koppers Bitumastic 300-M, or equal.

SECTION 9

PAVING AND SURFACING

9-01 SCOPE:

This section covers cutting and replacing pavement for installation of utilities, as shown on the plans and as specified herein.

9-02 DESIGN CRITERIA

Reference SCDOT Standard Specifications for Highway Construction (latest edition)
Reference Spartanburg County Standard Specifications for Construction of Roads

9-03 CUTTING AND REPLACING PAVEMENT:

- A. Cutting: All pavement shall be neatly cut to a straight edge in advance of trenching, with the method of cutting subject to approval of the Engineer. Cutting pavement shall be sawed with suitable concrete saw cutting equipment. Pavement shall be cut 12 inches wider than the excavated area on each side. Ragged and irregular edges shall be redone.
- B. Trench Backfilling under pavement shall be as specified in SECTION 6 of these Specifications..
- C. Base for pavement shall be crusher run stone for all secondary highways and non-highway streets, and concrete for all primary highways. Base shall be placed in accordance with plan or encroachment permit details. Base width shall be as shown on the plans of encroachment permits for the various types pavement cuts.
 - 1) Crusher run stone shall be graded 1-1/2 inches and down, with fines being added if necessary. Stone shall be well mixed and compacted by tamping and rolling so as to prevent settlement. Crusher run base material shall be placed at the same time that the trench is backfilled. Backfilling to the top of the trench, to be cut out and replaced with base material at a later date, will not be allowed.
 - 2) Base for highway pavement and adjacent drives shall be 8 inches of crusher run stone, stabilized with 5% Portland cement. Base shall be thoroughly mixed prior to compaction.
 - 3) Base for non-highway pavement and adjacent drives shall be 8 inches of crusher run stone, without the addition of cement.

- 4) Concrete base shall consist of 10 inches of concrete. Concrete shall be designed to produce a compressive strength of 3000 psi at 28 days. Design of mix and source of supply shall be subject to approval of the Design Engineer.
- D. Pavement shall be replaced with the same type of pavement that existed prior to cutting, and shall consist of bituminous surfacing, bituminous plant mix pavement. The Contractor shall contact the highway department and obtain the specifications for the mix to be used for any one or group of pavement cuts.
- 1) Pavement shall be repaired within the same week that it is cut. If inclement weather delays pavement replacement, Contractor shall not cut additional pavement until he has notified the Engineer and received specific permission and instructions.
 - 2) For bituminous pavement or surfacing, the entire area to be resurfaced (including edges of existing pavement) shall be primed with an acceptable asphalt prime coat just prior to placing the new pavement.
- E. The Construction Details included with these specifications are general. The requirement of the agency having jurisdiction over the roadway which is being impacted by the work shall govern. Refer to CONSTRUCTION DETAIL NO. 23.
- F. All Work on State Highways shall be done in strict accordance with the South Carolina Highway Department requirements. It shall be the responsibility of the Contractor to familiarize himself with all such requirements. He shall obtain from the Owner a copy of all required encroachment permits, and shall conform to all requirements and stipulations therein.
- All Work on County Highways or Roads, Town or City Street shall be done in strict accordance with requirements of the agency having jurisdiction thereof. The Contractor shall secure permits from the applicable agency involved and furnish a copy to the District. Paragraphs A, B, C and D of this section also apply.

9-04 REMOVING AND REPLACING SIDEWALK:

Where pipe is to be placed under an existing concrete sidewalk, the concrete shall be removed in construction units unless their length is more than 10 feet, in which case, the concrete shall be cut as specified for pavement. Backfill shall be thoroughly compacted for the entire depth of the trench.

- A. Sidewalk shall be replaced with 3,000 psi concrete 4 inches thick, except for driveways where it shall be 6 inches thick. Concrete shall be placed monolithic and dressed off with a wooden float, brush and edging tool. Where pipe is to be placed

under a concrete walk, the Contractor may, with permission of the Engineer, install the pipe by boring instead of removing and replacing the walk.

- B. Curb and Gutter: If pipe is to be placed under curb and gutter, it shall be done by boring. No additional payment will be made therefore.

SECTION 10

GRASSING AND EROSION CONTROL

10-01 SCOPE

This section contains specifications for the materials, equipment, construction, measurement, and payment for the seeding, interseeding, fertilizing, applying nitrogen and lime when specified, and mulching in conformity with the Plans and the Specifications or as directed by the Engineer or Engineering Field Technician. Interseeding consists of the planting of centipede grass seed within the existing turf.

10-02 MATERIALS

A. General

At the time of delivery, the Contractor shall retain delivery tickets, packing slips, or other documentation for materials received in order to determine the application rate of materials.

B. Seed

Ensure that seed conforms to state laws and the requirements and regulations of the South Carolina Department of Agriculture (SCDA). Provide individually packaged or bagged and tagged varieties of seed that show the name of seed, net weight, origin, percentages of germination and purity, lot number, and other information required by the South Carolina Department of Agriculture. The Spartanburg Sanitary Sewer District, hereinafter referred to as the "District", reserves the right to test and reject or approve any or all seed before application of the seed. For mixtures of different types of seed called for in the seeding schedule, weigh and mix in the proper proportions.

C. Seeding Schedules

Unless otherwise provided, select the type of seeding from the tables shown below for the upper state regions as applicable to the project. The upper state region includes all of Spartanburg, Greenville, Union, and Cherokee Counties. The total seed rate in pounds per acre is the sum total shown for all the varieties of seed opposite the schedule number in the seeding schedules included herein.

Adhere to the following two seeding schedules.

Seeding Schedule for Permanent Vegetation Upper State				
Schedule No.	Common Name of Seed	Pounds/acre ¹		Planting Dates
		Rural	Urban	
1	Common Bermuda (hulled) ³	23	23	March 15 to August 14
	Sericea Lespedeza (scarified) ²	50	50	
	Kentucky 31 Fescue	50	60	
	Weeping Lovegrass ²	10	10	
2	Kentucky 31 Fescue	50	80	August 15 to March 14
	Sericea Lespedeza (unhulled, unscarified) ²	80	80	
	Common Bermuda (unhulled) ³	30	30	
	Weeping Lovegrass ²	10	10	
	Reseeding Crimson Clover ⁴	20	0	
	Annual Rye Grass ⁵	5	15	
	Rye Grain	20	0	
<p>Notes:</p> <p>¹ Includes rural areas adjacent to well-developed lawns.</p> <p>² Not required on shoulders, medians, etc. and on slopes under 5 feet in height.</p> <p>³ Do not use Giant Bermuda seed including NK-37.</p> <p>⁴ Inoculate Reseeding Crimson Clover in accordance with Subsection 810.2.4. Do not plant clover in medians or in rural areas adjacent to well-developed lawns.</p> <p>⁵ The use of Italian Rye Grass is prohibited on all projects.</p>				

Adhere to the following schedule for interseeding.

Interseeding Schedule			
Schedule No.	Common Name of Seed	Pounds per acre	Planting Dates
1	Centipede	10	October 15 to July 15

810.2.3.3 Temporary Vegetation Seeding Schedule

Adhere to the following seeding schedules for temporary vegetation.

Seeding Schedules For Temporary Vegetation Upper and Lower State			
Schedule No.	Common Name of Seed	Pounds per acre	Planting Dates
1	Brown Top Millet	50	April 1 to August 15
2	Rye Grain	55	August 16 to March 31
	Annual Ryegrass ¹	15	
¹ The use of Italian Rye Grass is prohibited on all projects.			

Add oat grain at the rate of 10 pounds per acre to schedules if the seeding date is between March 1 and April 16.

D. Inoculants

Provide an inoculant for treating reseeding crimson clover seed of a pure culture of nitrogen-fixing bacteria selected for a maximum vitality and ability to transform nitrogen from the air into soluble nitrates and deposit them into the soil. Ensure that inoculants consist of purebred cultures and are not more than one year old.

E. Commercial Fertilizer

Provide commercial fertilizers that comply with state fertilizer laws. When a fertilizer is required for any grass, use a mixed fertilizer with a designation such as 10-10-10, where the first number represents the minimum percent of nitrogen required, the second number represents the minimum percent of available phosphoric acid required, and the third number represents the minimum percent of water soluble potash required in the fertilizer. For centipede grass, use only 15-0-15 or 16-4-8 fertilizer.

F. Lime

Ensure that lime is agricultural grade, standard ground limestone conforming to the current *Rules, Regulations, and Standards of the Fertilizer Board of Control*. These rules, regulations, and standards are promulgated and issued by the Fertilizer Board of Control at Clemson University in accordance with Section 16 of the South Carolina Liming Materials Act. Ensure that each bag has affixed in a conspicuous manner a tag or label, or in the case of bulk sales, a delivery slip showing the brand or trade name, calcium carbonate equivalent, percent by weight passing prescribed U.S. Standard

sieves, and other pertinent information to identify lime as agricultural grade, standard ground limestone. The Contractor may substitute liquid lime for ground lime if it meets all requirements for agricultural grade lime specified herein, except percent by weight passing U.S. Standard Sieves, which is waived for liquid lime.

G. Tackifiers as Mulch Binders

1) Emulsified Asphalt

If emulsified asphalt is used as a tackifier, ensure that emulsified asphalt is diluted at the manufacturing plant with water, if necessary, to provide a homogenous and satisfactory material for spraying.

2) Chemical Tacking Agents

If a chemical tacking agent is used, ensure that it consists of a polymer synthetic resin, polypectate, liquid latex, or other material that gives similar adhesive properties as asphalt emulsion when sprayed on straw and cellulose fiber mulches. Chemical tacking agents require approval by the District Engineering Department.

H. Straw Mulch

Use straw mulch material consisting of straw or hay. Use straw that consists of stalks of wheat, rye, barley, oats, or other approved straw. Use hay that consists of Timothy, Peavine, Alfalfa, Coastal Bermuda, or other grasses. Ensure that these materials are reasonably dry and reasonably free from mature seed-bearing stalks, roots, or bulblets of Johnson Grass, Nutgrass, Sandburg, Wild Garlic, Wild Onion, Wild Mustard, Crotolaria, Pigweed, Witchweed, and Cocklebur. Comply with all state and federal domestic plant quarantine regulations.

I. Wood Fiber Hydroseeding Mulch

1) Use wood fiber hydroseeding mulch made from wood chip particles manufactured particularly for discharging uniformly on the ground surface when dispersed by a hydraulic water sprayer. Ensure that it remains in uniform suspension in water under agitation and blends with grass seed and fertilizer to form homogeneous slurry. Make certain that the fibers intertwine physically to form a strong moisture-holding mat on the ground surface and allow rainfall to percolate the underlying soil. Use a fiber material that is heat processed and contains no germination or growth-inhibiting factors.

2) Use a fiber material dyed (non-toxic) an appropriate color to facilitate the uniform application of material.

3) Use suppliers that certify that their product has been laboratory and field tested and meets all of the foregoing requirements based upon such testing. Ensure that the weight specifications from suppliers and for all applications of this material refer only to the absolute air-dry weight of the fiber material.

Absolute air-dry weight is based on the normal weight standard of the Technical Association of the Pulp and Paper Industry for wood fiber hydroseeding mulch and is considered equivalent to 10% moisture. Ensure that the manufacturer marks each package of the wood fiber hydroseeding mulch to show the air-dry weight content.

- J. Cellulose Fiber Hydroseeding Mulch
Use cellulose fiber hydroseeding mulch consisting of recycled magazine stock products shredded into small pieces for application by hydraulic seeding equipment. Ensure that it mixes readily and uniformly under agitation with water and blends with grass seed and fertilizer to form homogeneous slurry. When applied to the ground surface, ensure that the material forms a strong moisture-holding mat, allows rainfall to percolate to the underlying soil, and remains in place until the grass root system is established. Ensure that the material contains no growth inhibiting characteristic or organisms. Obtain mulch from suppliers that certify that their product meets these requirements.

10-03 INSTALLATION OF GRASS AND RELATED MATERIALS

- A. Seeding Dates and Rates of Application
Perform seeding during the periods and at the rates specified in the seeding schedules above. The Contractor may perform seeding work throughout the year using the schedule prescribed for the given period. Do not conduct seeding work when the ground is frozen or excessively wet. Produce a satisfactory stand of grass meeting the requirements of this section, regardless of the period of the year in which the work is performed. Perform interseeding during the periods and at the rates specified in the interseeding schedule. Conduct the interseeding with a no-till drill calibrated to deliver the specified rate of seed per acre.
- B. Preparation of Ground Before Seeding
Ensure that the areas seeded are uniform and conform to the finished grade and cross-section shown on the Plans or as otherwise directed by the Engineer. Perform minor shaping and evening of uneven and rough areas outside the graded section as needed in order to provide for more effective erosion control and ease of subsequent mowing operations. Loosen the seedbed (including cut slopes) to a minimum depth of 3 inches before agricultural lime, fertilizer, or seed is applied. Clear the areas to be seeded of stones larger than 2½ inches in any dimension, roots, and other debris. Temporarily seed slopes to coincide with the embankment work in 10-foot increments. When 10 feet of fill is in place, seed the slope. Track the slopes vertically to help hold the seed in place.
- C. Applying Organic Topsoil
At areas to be grassed where the existing seedbed has little or no topsoil, topsoil may be furnished and placed on the seedbed to ensure a good stand of grass.

D. Applying Lime and Fertilizer

When called for in the Contract, spread lime and/or fertilizer uniformly over the designated areas and thoroughly mix with the soil to a depth of approximately 2 inches. Apply fertilizer at the rate of 1000 pounds per acre unless otherwise directed.

Apply lime at the rate of 2000 pounds per acre, unless otherwise specified. Unless otherwise provided, do not apply lime for temporary seeding. Adequately scarify steep slopes, which are inaccessible to power equipment and are subject to slides. Fertilizer may be applied as a mixture of fertilizer and seed by approved mechanical spreaders or by hydraulic methods. When fertilizer is applied in a combination seed and fertilizer drill, no further incorporation is necessary. Apply the fertilizer and seed together when the hydraulic method of seeding is used. Remove all stones larger than 2½ inches in any dimension, larger clods, roots, or other debris brought to the surface. Fertilizer of a different analysis than that specified on the Plans may be substituted if approved by the Engineer. If a different fertilizer is approved, apply the fertilizer at such a rate per acre to give at least the amount of nitrogen, phosphoric acid and potash as would have been accomplished had the originally specified fertilizer been used and applied at the specified rate. If the substitute fertilizer meets the minimum analysis of at least one or more of the three basic ingredients, do not consider the excess in calculating the required quantity of the substituted fertilizer. Payment is made for the number of tons of fertilizer which would have been required if the originally specified fertilizer had been used at the specified rate. For Interseeding, apply fertilizer at the rate of 500 pounds per acre. Use 15-0-15 or 16-4-8 fertilizer.

E. Permanent Vegetation

Produce a satisfactory stand of perennial vegetation with a root system that is developed sufficiently to survive dry periods and winter weather, and is capable of re-establishment in the spring. The perennial vegetative cover must have a minimum coverage density of 70% for the seeded areas. Using the seed specified above, determine the rate of application necessary to produce the required stand of grass and follow the application procedures as specified herein.

F. Temporary Vegetation

Obtain a satisfactory stand of vegetation that is capable of erosion control. Using the seed specified above, determine the rate of application necessary to produce the required results. Ensure that the temporary vegetation provides minimum density coverage of 70% of the seeded area.

G. Temporary Seeding

Sow seed within 24 hours following the application of fertilizer and preparation of seedbed as specified above. Sow seed at the required rate by hand or by methods as outlined above. Compact or cover the seeded areas as specified above. On small areas inaccessible to machinery, the Contractor may cover the seed by hand rakes or other methods satisfactory to the Engineering Field Technician. Apply fertilizer at the rate of 500 pounds per acre or as directed by the Engineering Field Technician. Lime is not required in temporary seeding unless otherwise specified. No tackifiers or mulches are required for temporary seeding. The Contractor may use temporary

seeding in isolated problem areas or, where it is not feasible or practicable to bring an area to final slope, grade and finish so that the permanent seeding can be performed without subsequent serious disturbance by additional grading.

H. Seeding (Unmulched)

Ensure seeding without mulch (unmulched) conforms to Method A or B as prescribed below, except do not use Method A in urban areas or in areas adjacent to sidewalk, guardrail, curb, curb and gutter, or concrete median.

1) Method A: Seeding with Emulsified Asphalt Tackifier

Sow seed within 24 hours following the application of fertilizer and lime and preparation of the seedbed as specified above. Uniformly sow seed at the rate specified by the use of approved mechanical seed drills, rotary hand seeders, hydraulic equipment, or any other type of equipment that produces a uniform application of the seed. Except on steep slopes where mechanical equipment cannot operate satisfactorily, compact all seeded areas by means of a cultipacker or light roller. Compaction is not necessary if seeds are planted by mechanical seed drills that perform a compaction procedure. On slopes that are inaccessible to compaction equipment, cover the seed by dragging spiked-chains, by light harrowing, or by other methods satisfactory to the Engineer. Within 24 hours following compaction of the seeded areas, uniformly apply emulsified asphalt, diluted at the manufacturing plant with an equal amount of water, over the seeded areas at a rate of 0.15 to 0.32 gallon of the dilution per square yard. The RCE will determine the exact rate of application. Before spraying emulsified asphalt, cover parts of bridges, culverts, guardrail, signs, sidewalk, curb and gutter, catch basins, pipe ends, and other structures as necessary to prevent discoloration.

2) Method B: Seeding with Wood Fiber Mulch Tackifier,

Cellulose Fiber Mulch Tackifier, or Wood/Cellulose Fiber Mix Tackifier
Apply lime and prepare the ground as shown on the Plans or as provided above. Choose one of the following tackifiers: wood fiber tackifier, cellulose fiber tackifier, or wood/cellulose fiber mix tackifier and apply with a mixture of water, seed, and fertilizer at the rate of 1500 pounds per acre. Use hydraulic equipment for the application of slurry of water, fertilizer, seed, fiber, and tackifier. Use equipment with a built-in agitation system and an operating capacity sufficient to agitate, suspend, and homogeneously mix the slurry. Ensure that the slurry distribution lines are large enough to prevent clogs. Equip the discharge line with a set of hydraulic spray nozzles to provide even distribution of the slurry on the various areas seeded. Use a slurry tank with a minimum capacity of 1000 gallons. Combine all of the seed, fertilizer, tackifier, and water into the slurry tank for distribution of all ingredients in one operation by the hydraulic seeding method specified herein. Combine the materials in a manner recommended by the manufacturer. Regulate the slurry mixture so that the amounts and rates of application result in a uniform application of all materials at rates not less than the amounts

specified. Using the color of the slurry as a guide, spray the prepared seedbed with a uniform visible coat. Apply the slurry in a sweeping motion in an arched stream falling like rain and allow the slurry to build upon itself until an even coat is achieved.

I. Seeding (Mulched)

Ensure that seeding with mulch conforms to Method A, B, or C as prescribed below, except do not use Method A in urban areas or in areas adjacent to sidewalk, guardrail, curb, curb and gutter, or concrete median.

1) Method A: Seeding with Straw or Hay Mulch

Sow seed as specified in Method A of Section I above. Within 24 hours following covering of the seed, uniformly apply straw or hay mulch material at the rate of 2 tons per acre. Spread mulch by hand, by appropriate mechanical spreaders, or by blowers. Use mulch that allows sunlight to penetrate and air to circulate but also partially shades the ground and conserves soil moisture. Use emulsified asphalt meeting the requirements of Section 10-02 H. above, or other approved tacking agent, to hold the newly laid mulch in place. Ensure that the emulsified asphalt is diluted at the manufacturing plant with an equal amount of water. Uniformly apply the material as a film over the mulch at approximately 0.20 gallon of dilution per square yard. Make certain that the film is sufficient to bond together the mulch particles without giving a heavy coating of the asphalt material. Ensure that the film prevents wind erosion. Other tacking agents may be used and applied at the manufacturer's recommended rate. Replace displaced mulch.

2) Method B: Seeding with Straw and Hydroseeding Mulch

Apply seed as in Method A of Section I above, then cover with straw tacked with the manufacturer's recommended rate of wood, cellulose, or a wood/cellulose mix hydroseeding mulch; or straw tacked with manufacturer's recommended rate of a combination of tacking agent and any of the aforementioned hydroseeding mulches.

3) Method C: Hydroseeding

Hydroseed using 1500 pounds per acre of wood, cellulose, or a wood/cellulose mix hydroseeding mulch with the manufacturer's recommended rate of an approved tacking agent.

J. Application of Nitrogen

As soon as the plants show satisfactory growth, apply nitrogen evenly at the rate of 48 pounds per acre on the areas designated by the RCE. Unless otherwise permitted, apply the nitrogen in a solid form rather than in a liquid state. Do not apply nitrogen to stands of *sericea lespedeza*. Unless otherwise provided, do not apply nitrogen to temporary vegetation.

10-04 TURF MAINTENANCE

A. Mowing

Mow areas seeded or sodded , or other areas as necessary, to maintain the project in a satisfactory manner. Perform mowing where directed by the Engineer. Commence mowing within three business days following verbal notification by the Engineer. Failure to comply with the above may be grounds for stopping work on the project (or withholding payment of the next pay estimate if a Capital project)

- 1) Use mowing equipment equipped with safety devices designed to prevent injury or property damage caused by flying debris propelled from under the mowing equipment. Keep all mowing equipment in good operating condition and maintain to provide a clean, sharp cut of vegetation at all times. If the Engineering Field Technician (EFT) determines the equipment is defective to the point that the quality of work or safety is affected, immediately repair or replace the equipment.
- 2) Ensure that mowing results in a vegetation height of 4 to 6 inches, unless otherwise directed by the EFT. Mow as closely as possible to all fixed objects, exercising care not to damage trees, plants, shrubs, signs, delineators, r other appurtenances that are a part of the facility. Hand trim around such objects if required and to the satisfaction of the EFT.
- 3) Immediately remove and properly dispose of any debris thrown on the roadway by the mowing operation. Mowed grass is not normally removed unless it becomes a hazard. Do not perform mowing when, in the opinion soil and weather conditions are such that rutting or other damage to the project may occur. The three-business day period noted above will be extended until the soil and weather conditions become suitable for mowing on the project.

B. Maintenance

Perform all maintenance necessary to keep seeded areas in a satisfactory condition until the work is finally accepted. This includes mowing, repairing washes, and additional applications of seed, fertilizer, and mulch to areas where a satisfactory stand of grass has not been achieved.

C. Stand of Grass

Before acceptance of the seeding performed for the establishment of permanent vegetation, produce a uniform perennial vegetative cover with a density of 70% of the seeded area. Ensure that the root system is developed sufficiently to survive dry periods and winter weather and is capable of reestablishment in the spring. Before acceptance of the seeding performed for the establishment of temporary vegetation, produce a stand of grass sufficient to control erosion for a given area and length of time before the next phase of construction or the establishment of permanent vegetation commences

10-05 EROSION CONTROL MEASURES

Ensure that the equipment necessary for the proper construction of the work is on site, in acceptable working condition, and approved by the Engineering Field Technician as to both type and condition before the start of work under this section. Provide sufficient equipment to enable the work to proceed in accordance with the project schedule and completion of the work in the specified time.

A. Partial and Temporary Seeding

Coordinate seeding with the construction of cut and fill slopes. Limit the area of erodible material by bringing partially completed slopes to the required slope and perform seeding operations as soon as feasible. Temporarily seeding of slopes shall coincide with the embankment work.

B. Erosion Control Measures

In addition to the erosion control measures specified herein and in the Plans and the Special Provisions, the Contractor is advised that all land disturbing activities (clearing and grubbing, excavation, borrow and fill) are subject to the following requirements

- 1) Work must be conducted in accordance with the requirements of applicable permits and Federal, State, and local regulations;
- 2) All necessary permits must be obtained prior to the commencement of land-disturbing activities.
- 3) Copies of all permits, sedimentation and erosion control plans, etc. shall be kept on site at all times until the project is closed out.
- 4) The Contractor shall retain primary responsibility for compliance with all regulations and may be subject to fines or other penalties for any violations regardless of a lack of knowledge of those regulations.

SECTION 11

SEWER PUMP STATIONS

11-01 SCOPE:

This section covers the installation/construction of sewer pump stations including all labor, materials, tools, equipment and performance of all work necessary or incidental to furnish a pump station as shown on the plans and specified herein.

11-02 DESIGN CRITERIA

A gravity sanitary sewer system shall be constructed, as needed, to provide sanitary sewer service to residential or commercial developments. The following specifications shall apply to those projects for which a sewer pump station has been approved by the Spartanburg Sanitary Sewer District, hereinafter referred to as the "District".

- A. The design and construction of sewer pump stations in the District shall comply with the current version of the SCDHEC Standards for Wastewater Facility Construction: R.61-67.300, C.
- B. The Engineer should submit the following design calculations:
 - 1) Station service area Design Wastewater Flows. Wastewater flows shall be calculated for the following conditions:
 - a. Start-up and service area build-out Peak Hourly Flow (PHF).
 - b. Start-up and service area build-out Average Daily Flow (ADF).
 - c. Flows shall be calculated in accordance with Appendix A of SCDHEC Standards for Wastewater Facility Construction: R.61-67. The Owner's Engineer may be required to evaluate the impact of the new flow on existing downstream gravity systems or pump stations. The District reserves the right to require upgrades to downstream pump stations, or gravity systems, which do not have adequate capacity to accept the additional flow.
 - 2) Hydraulic Analysis
 - a. The Engineer shall evaluate and design the pump/force main system and select pump(s) and force main(s) to provide the required capacity and pressure.

- b. The Engineer shall develop hydraulic system curves that indicate the required pump operating conditions. System curves shall be developed for pump suction (if applicable) and discharge piping, and shall include all valves, fittings and other items that may cause energy losses. Analysis shall be provided showing the effects of new and old pipe conditions, the net positive suction head requirements, the hydraulic efficiency, the horsepower requirements, the revolutions per minute, and other operating conditions required for each pump and combination of pumps.
 - c. Hydraulic system curves shall be developed using the Hazen-Williams equation for “C” factors which are consistent with the force main pipe, both for new and old pipe condition and under high and low wetwell conditions. Hydraulic system curves shall be overlain on the manufacturer’s pump curves. Computer generated curves may also be included. The Engineer shall provide pump and system curves for the selected pump(s) to the District for review and approval.
 - d. Depending on the application, the District may require that the pump design include a provision for upgrade for future flow by changing impellers only.
- 3) Force main velocity between 2 and 5 feet per second with one pump operating;
 - 4) Wet well dimensions and pump control set points shall provide for the following:
 - (4) cycles/hour for average daily flow
 - (10) cycles/hour for peak flow
- Inlet gravity piping shall not be used to improve storage.
- 5) Provide certification that motor and control circuits will permit ten (10) cycles/hour;
 - 6) Minimum 2 pumps of equal capacity capable of handling the expected peak flow;
 - 7) Flotation calculation for wet well;
 - 8) Pump station must be operational during flooding to the 25-year flood elevation, and station structures and equipment shall be protected from physical damage due to flooding to the 100-year flood elevation.
 - 9) An all-weather access road shall be provided

10) Each pump station shall be fenced or secured in a locked building or enclosure or located in a restricted area to prevent access by unauthorized persons.

11) Water Hammer

- a. The Engineer shall consider the potential impact of water hammer and cyclic loadings that are inherent in wastewater force mains. In circumstances where water hammer may be a concern (force main discharging at a higher elevation than the pump station, force main profile with significant elevation changes, etc.) the District may require that the Engineer submit a detailed water hammer (surge) analysis.
- b. All elements of the piping system must be designed to withstand the maximum water hammer in addition to the static head and cyclic loading.
- c. The District may require that any or all of the following provisions be included in the designed methods of addressing water hammer in force main systems
 - 1. The addition of surge control devices (surge valves) in the piping system;
 - 2. The addition of variable frequency drives (VFDs) or “soft-starters” as part of the pump motor control equipment;
 - 3. Strengthening of piping system components.

f. Hydrogen Sulfide Potential

Engineer shall evaluate the hydrogen sulfide potential in accordance with the following guidelines. Hydrogen sulfide controls shall be designed and constructed based on the following:

- a. Detention Time less than 35 minutes: No hydrogen sulfide controls required.
- b. Detention Time 35 to 90 minutes: Protect the force main discharge manhole with a protective coating. Products shall be approved by the District. (Refer to SECTION 3 of this Document). The District reserves the right to require the protective coating of additional, downstream manholes.
- c. Detention Time greater than 90 minutes: Install an active hydrogen sulfide control system. There are a variety of technologies which have been developed to address the problem of hydrogen sulfide in sewer systems, both from an aesthetic (odor) concern and from an

equipment (corrosion) concern. The District reserves the right to require that the Engineer submit for review a control system which addresses both concerns.

13) Electrical service

- a. All sewer pumps shall be designed to operate on 3-phase electrical power. However should 3-phase power not be readily available, the District may approve the installation of an appropriate Variable Frequency Drive (VFD) to supply 3-phase power to the pumps. Refer to Section 11-04 J.
- b. If an Engineer proposes the installation of single-phase motors and VFD's as an alternative to extending 3-phase power to the site, the District may require the submission of an economic comparison of these alternatives during the design review.

11-03 SUBMITTALS:

A. Shop Drawings shall be submitted for review and shall include the following:

- 1) Design calculations as required under SECTION 11-02 above.
- 2) Pump and motor manufacturer's data to show conformance with the plans and specifications, including drawings showing station dimensions, details and location of accessories, clearances required, capacity, functional description, and pump delivery curves.
- 3) Construction materials including precast concrete, all hardware and accessories, chain link fence materials,
- 4) Detailed description of controls including wiring diagram for all panel controls and electrical equipment, and all miscellaneous appurtenances.

B. Pump Test: A written report of pump tests shall be provided with each pump prior to shipment. Standard Running Tests shall be performed to show characteristic curves for each pump, showing actual performance. Pump tests shall be Standard running Test by the manufacturer based on criteria of the test code of the Hydraulic Institute Standards for Centrifugal Pumps. The District may require that the manufacturer furnish Factory Certified performance curves for each pump.

C. Service Manuals shall be furnished for each type of equipment specified in this section. The manual shall contain a description of equipment, complete accessory and parts list, and complete installation, operation and maintenance instruction, and trouble shooting procedures. A draft copy of the Service Manual shall be submitted prior to the testing described in SECTION 11-07 A., and the completeness and accuracy of the Manual shall be checked by the Manufacturer's Representative and the District's EFT. After final approval of the Manual three copies of the approved

manual shall be provided.

- D. Changes in structures, piping, electrical work, or other work which is necessary to accommodate equipment supplied by the Contractor shall be made at no additional cost to Owner. No equipment structure shall be constructed until certified equipment dimensions and requirements are available to the Contractor in the form of approved shop drawings.

11-04 MATERIALS AND EQUIPMENT:

Major items of equipment shall include (but are not limited to) the following:

- A. For Submersible and Suction-lift Stations (either configuration is acceptable)
- 1) Non-clog sewage pumps, either submersible or self-priming capable of passing a 3" sphere;
 - 2) Each pump shall have the necessary characteristics and be properly selected to perform under the operating characteristics shown in the Engineer's design calculations.
 - 3) Flanged spring-and-lever check valves;
 - 4) Flanged AWWA resilient seat, hand-wheel operated, gate valves with non-rising stem or fully-ported, lever operated, plug valves;
 - 5) Flanged ductile iron discharge piping and fittings
 - 6) A tee, valve, and male cam lock quick-connect coupling arrangement to provide bypass pumping capability. All bypass piping components shall be located in a below-grade vault to provide freeze protection. On submersible pump stations, the bypass piping may be incorporated within the valve vault, provided the vault is properly sized to permit access for maintenance. Refer to CONSTRUCTION Detail No. 24.
 - 7) Pressure Gauges:
 - a. Submersible pump stations shall have a pressure gauge installed prior to each discharge check valve and a single pressure gauge downstream of the check valves and gate valves.
 - b. Suction-lift pump stations shall have a pressure gauge installed prior to each discharge check valve and a vacuum gauge installed on the suction piping;
 - c. Pressure and vacuum gauges shall be minimum 4.5" diameter and shall display both PSI and feet of water head;

- d. Gauges shall be equipped with isolation ball valves to allow removal of gauges while the station is in operation.
 - e. Gauges shall be mounted so that they may be read without the need for personnel to enter the valve vault on submersible stations.
- 8) Non-rising stem gate valve located in ground outside of valve pit supplied with tee handle;
 - 9) One double door aluminum wet well equipment access hatch with fall-protection grating; Refer to CONSTRUCTION DETAIL NO. 25.
 - 10) One stainless steel duplex central control panel mounted in a free standing panel;
 - 11) Level control shall be via MultiTrode level sensing and control system with float back-up;
 - 12) 2 mercury-free back-up float switches with mounting bracket;
 - 13) Pump Station monitoring shall be performed by the unit supplied by Generating Solutions and shall be compatible with the current monitoring package in use by the District;
 - 14) 3" vent duct with screen;
 - 15) Wet well with monolithically cast base and risers
 - 16) Spare parts shall be provided as follows: 1 upper and 1 lower mechanical seal for the duplex pump station.
 - 17) Potable water supply with backflow prevention device
 - 18) The perimeter of the pump station site shall be enclosed with chain link fence . The entrance gate shall be 20 feet in width (2 panels, 10 feet each) and shall be aligned to provide the most-suitable access to the wet well by a vacuum truck. Refer to SECTION 11-05 and CONSTRUCTION DETAIL No. 26
 - 19) The manufacturer's technical representative shall inspect the completed installation, correct or supervise the correction of any defect, and instruct the operating personnel in the proper operation and maintenance of the equipment.

B. For Submersible Stations

- 1) Submersible Non-Clog Sewage Pumps: The pumps shall be designed to pump raw sewage wastewater, sludge and other fibrous materials without injurious damage during operation. The design shall be such that the lifting cover,

stator housing and volute casing are of ASTM A48, Class 25 gray iron construction, with all nuts, bolts, washers and other fastening devices coming into contact with the sewage constructed of 316 stainless steel. Pumps shall be Flygt, ABS, or Smith & Loveless.

- 2) Seals: Motors shall be protected by tandem mechanical seals running in an oil bath. Seal chamber shall be oil filled to lubricate seal face and to transmit heat from shaft to outer shell. Seal faces shall be lapped tungsten carbide and welded to stainless steel retainers; seal faces shall be lapped to a flatness of one light band. The upper seals shall be tungsten carbide against carbon and lower seals are to be tungsten carbide. A double electrode shall be mounted in the seal chamber to detect any water entering the chamber through the lower seal. Water in the chamber shall cause a red light to turn on at the control box. This signal shall not stop motor but shall act as a warning only, indicating service is required. One spare upper and lower seal each shall be provided by the manufacturer for each duplex pump station.
- 3) Impeller shall be cast iron and of the non-clog enclosed type. The impeller shall be of hard alloy gray iron construction, dynamically balanced, double shrouded, single vane, with a smooth long thoroughfare and having no acute angles, capable of passing a minimum 3" solids. A stainless steel rotating wear ring shall be installed on the impeller with stationary volute wear ring of nitrile rubber, to provide efficient sealing between the volute and impeller. Impeller is to be driven by stainless steel shaft key and impeller is held in place with stainless steel lock screw and washer. Impeller and motor shall lift off of case as a unit without disturbing piping.
- 4) Motors: The pump motors shall be non-overloading for full performance range, of Class F insulation, NEMA B design, rated 155° C maximum, 1.10 minimum service factor and housed in a watertight housing. The motor housings shall be air filled. Motor is to be heat shrink fit in the housing, no bolts, pins or other fastening devices shall be allowed. Motors shall not contain any insulating fluid consisting of material classified as hazardous waste by the EPA such as tetrachloroethylene or PCB. Motors shall be provided with thermal sensors in the motor windings designed such that the pump will automatically shut off and set off an alarm condition on high temperature condition. Motor shall be designed for continuous duty, capable of sustaining a minimum of ten (10) starts per hour with motor housing completely unsubmerged. Pump and motor shall be a product of the same manufacturer.
- 5) Power Cords and Control Cords shall be double sealed. Sufficient cord shall be provided to suit the arrangement shown on the plans, minimum 25 ft. of each cord. The cable shall enter the pump through a heavy duty entry assembly, which shall be provided with single cylindrical grommet flanked by stainless steel washers to protect against leakage. Epoxies, silicones or other secondary systems are not acceptable. The cable must have a strain relief assembly as part of standard construction. The power cord shall connect to a terminal board in the pump which separates the incoming service from the

pump motor. Wire nut connectors are not acceptable. Insulation of power and control cords shall be type SO or STOW. Both control and power cords shall have a green carrier ground conductor that attaches to motor frame. Power cords and control cords shall junction at a NEMA 4X box mounted outside the well, but not inside the control panel. Cords shall be connected in a manner to allow removal of pumps for maintenance.

- 6) Discharge Elbow: The discharge elbow shall be permanently installed in the wet well along with the discharge piping. The entire weight of the pump shall be supported by the elbow.
- 7) Discharge Coupling: Each pump shall be supplied with a sliding guide bracket which shall be an integral part of the pump volute and accepts the discharge elbow specified elsewhere. The pump shall be guided into position by two stainless steel pipes, 2 inches in diameter. Seal of the pump at the discharge flange is to be accomplished by a simple downward linear motion of the pump with the entire weight of the pump guided to and pressing against the discharge connection; no part of the pump shall bear directly on the station floor and no rotary motion of the pump shall be required for sealing. Sealing at the discharge is to be effected by either a metal to metal contact or by a proprietary replaceable , resilient seal, to insure a positive leak proof system and for ease of removal. The pump shall be guaranteed not to leak at the discharge flange. Other forms of guiding, such as straightening vanes, etc., shall not be considered equal.
- 8) Pump Guide Rails with End Brackets shall be provided for each pump. Guide rails shall be 2.0 inch, type 316 stainless steel pipe with an intermediate stainless steel support. Each pump shall connect automatically and firmly to the discharge piping when lowered into place. It shall not be necessary to enter the wet well to remove or replace a pump.
- 9) Complete flanged discharge piping and 90° elbows inside the wet well;
- 10) In addition to the general pump tests listed in Paragraph 11-03 B), additional tests specific to submersible pumps shall be required as follows;
 - a. The Test shall include motor and cable insulation and moisture test, 30 minutes operation at a submerged depth of at least six feet and
 - b. A second insulation of moisture test after submerged operation.
 - c. This shall be in addition to, or in conjunction with the Standard Running Test.

C. For Suction-lift Stations

- 1) Design requirements consist of a factory-built pump station package which shall be the product of a single supplier who assumes responsibility for the

integration and proper operation of the specified components.

- 2) The station shall be complete with all equipment specified herein, including a prefabricated enclosure which includes provision for access by service personnel for routine inspections, as well as for all required maintenance, including complete removal of pumps, motors, piping, controls, etc.
- 3) In addition to the station enclosure, principle items of equipment shall include
 - a. Two self-priming (or vacuum priming), centrifugal sewage pumps,
 - b. Direct drive, or V-Belt drive
 - c. Motors,
 - d. Suction and discharge piping
 - e. Valves, including discharge check valves and bypass arrangement;
 - f. Motor Control Panel
 - g. automatic liquid level control system, and internal wiring;
- 4) Pump Design:
 - a. Pumps shall be self-priming or vacuum priming, centrifugal type, designed specifically for handling raw, unscreened, domestic sanitary sewage;
 - b. The rotating assembly, which includes the impeller, shaft, mechanical shaft seal, lip seals, bearings, seal plate and bearing housing, must be removable as a single unit without disturbing the pump casing (volute) or piping.
 - c. Shaft seals, impeller, and motors shall comply with the requirements given in paragraphs 11-03, B. 2) through 4) above;
 - d. Adjustments of the impeller face clearance shall be accomplished by external means.
- 5) The need for a suction check valve shall not be required as part of the re-priming operation;
- 6) The pump must demonstrate the ability to reprime and deliver full capacity within 5 minutes after the pump is energized in the un-primed condition, test fluid shall be water;
- 7) Suction and discharge pressures shall be monitored by oil-filled gauges, graduated in PSI and feet of water, mounted in a resilient panel which will reduce vibration of the gauges. Gauge installations shall be complete and shall include a shutoff valve for each gauge at the point of connection to the suction and discharge pipes.
- 8) Station Enclosure:

- a. The station enclosure shall contain and protect all pumps, interior piping, valves, and associated controls.
 - b. A blower shall be provided to exchanged station air volume at least once every 2 minutes. Blower shall energize automatically at approximately 70°F and turn off at 55°F and shall be protected by a circuit breaker. Exhaust and inlet locations shall prevent the entrance of rain, snow, or debris.
 - c. A 1300/1500 watt, 115V electric heater shall be provided with cord and grounding plug;
 - d. Interior fluorescent or incandescent lighting shall be provided and shall comply with local building codes.
 - e. All access hatches and/or doors shall be equipped with heavy-duty, galvanized padlock hasps, compatible with padlocks which shall be supplied by the District;
- 9) Station Enclosure Warranty: In addition to the general warranty requirements presented in SECTION 11-07, the pump station manufacturer shall warrant all equipment which is specific to the station enclosure to be of quality construction, free of defects in material and workmanship. A written warranty shall include specific details described below:
- a. Fiberglass components of the station enclosure shall be warranted for 20 years to resist UV damage or corrosion from moisture without the use of special protective coatings.
 - b. All other equipment and parts shall be warranted for 5 years except for those items normally consumed in service such as light bulbs, oils, grease, etc.
 - c. Components failing to perform as specified shall be repaired or replaced by the manufacturer or his representative without cost of parts or labor to the District.

D. Wet well structure

- 1) One monolithically cast base section and a 12-inch long base slab extension for counter flotation.
- 2) The wet well risers/top sections shall have a minimum wall thickness of 7".
- 3) Both top slab and bottom slab shall have a minimum thickness of 8".
- 1) Openings in the wet well Sections may be cast-in or cored, with the exception

of the influent pipe opening which shall be cored in the wall. Wet well diameter and height shall be as shown on the plans or directed by the Engineer.

- 2) All precast concrete units shall be poured and vibrated using steel forms, in a PCI (Prestressed Concrete Institute) certified manufacturing facility. The complete pump station shall be manufactured by Tindall Concrete Products, or approved equal.

E. The valve vault

Shall consist of a concrete structure (round or rectangular in shape) sized to adequately house the equipment and allow room for removal of equipment and regular maintenance. Refer to CONSTRUCTION DETAIL NO. 24

- 1) Depth shall be as shown on the plans.
- 2) All pipe wall penetrations shall be through cast-in or cored holes with flexible rubber sealing connections (manhole boot);
- 3) The bottom slab of the structure shall have a minimum thickness of 6" with a grout slope bottom to a 3-inch diameter drain with flap valve on the end returning to the wet well.

F. Concrete cement shall be Type II, having a maximum Tri-calcium aluminate (3CaOAL2O3) content of 8%. Coarse aggregate shall be sound, crushed, angular granitic stone only. Smooth or rounded stone is not acceptable. Fine aggregate and coarse aggregate shall meet the requirements of ASTM C33. Calcium Chloride or admixtures containing Calcium Chloride shall not be used in the concrete mix.

G. Reinforcing shall meet or exceed the minimums described in ASTM C478.

H. Flexible Pipe-Connectors: Watertight connections between all pipe and wet well shall be achieved with flexible pipe connectors conforming to ASTM C923.

I. Electrical Controls: Controls shall be provided in a separately mounted NEMA 4X enclosure either mounted on the rack or mounted within the pump station enclosure. The Controls shall include all devices necessary to receive phase volt cycle power and shall perform functions described herein. Refer to CONSTRUCTION DETAIL NO. 27.

- 1) The Main Control Panel enclosure shall be provided with a lockable blank front panel door with all control functions mounted inside the enclosure on a sub-panel (unless the panel is located inside the suction-lift station lockable enclosure). Panel wiring and devices shall meet standards of the National Electric Code (NEC) and NEMA. All wiring shall be color coded, numbered, bundled and tied, minimum 16 gauge, Type MTW or THW 600 volt, inside the panel. Terminals, wires and connections shall be identified on the wiring

diagram shop drawings and in the service manual. Internal components shall be identified by nameplates. Enclosures shall have an outside deadfront and hasp for padlocking. Interior lights, switches, starter resets, elapsed time meters, circuit breakers and other operator devices shall be located on a separate interior face panel hinged to allow access to internal wiring and other devices. Panel frame, circuits and conduits shall be grounded to meet NEC.

- 2) The Main control panel shall be equipped with the following:
 - a. An adequately sized main circuit breaker for each pump; circuit breakers shall be Westinghouse, Square D or GE.
 - b. A magnetic starter with three quick-trip, ambient-compensated overloads for each pump;
 - c. A 7-digit running time meter for each pump recording hours and tenths of an hour;
 - d. A green running indicator light (LED) for each pump,
 - e. "Hand-Off-Automatic" selector switches for each pump
 - f. A red seal failure indicator light (LED) for each pump (submersible pumps only)
 - g. Switches shall be heavy duty type K,
 - h. All indicator lights shall be LED's.
 - i. A terminal set of dry contacts shall be provided for monitoring the following conditions:
 - i. Pump Failure for any condition (overload, circuit breaker trip, over-temperature);
 - ii. High level alarm
 - iii. Any power-related trouble (phase loss, low voltage, control power loss, etc.);
 - iv. Wet well level (4-20mA)
- 3) Level Controls shall consist of the MultiTrode MTDPC - Basic Two Pump Controller and the MultiTrode Probe. Backup liquid-level indication shall be provided by individual heavy duty tilt-type, mercury-free float switches (Consolidated Electric 9G, or equal).

- 4) Controls shall alternate the lead pump with the lag pump and shall, on rising water level, control the level of lead pump on, lag pump on and alarm on. On falling water level, controls shall turn all pumps off.
- a. The MultiTrobe Probe shall be mounted on the factory-supplied mounting bracket in a location which will not cause interference with pump removal.
 - b. Float switches shall be mounted on a stainless steel bracket within reach from the access hatch and away from incoming sewage turbulence. Each float switch shall be mounted on its own cord and shall be weighted individually to reduce the influence of turbulence. Ample extra cord shall be included to allow easy adjustment of float switches.
 - c. The pump controller shall automatically alternate lead and lag pump pumping cycle and shall automatically switch to the lag pump should the lead pump fail. Upon pump failure a red LED shall glow and remain on until the fault is corrected. The controller shall be equipped with built-in high water alarm circuit and shall display these conditions with a red LED. Green LED's shall also signal individual pump operation and identify which pump is acting as lead pump. A green LED shall indicate power to the controller. The controller for pump starting shall be such that only one pump can be started at a time. If both pumps are activated to run, then one shall not start until the other pump has started or obtained operating conditions (10 second delay).
- 5) An External Alarm shall be mounted outside as shown on the control panel. Alarm panel shall include a horn with minimum 100 dB at 20 feet, a flashing red light, a silence button, and a test switch to operate on 120 volt power supplied through the control panel. The silence button shall silence the horn. The light shall continue flashing until the alarm condition is corrected. The alarm shall include a spare contact to operate a telephone alarm system.
- 6) Dehumidifier or Heater. The Control panel shall be supplied with a condensation heater which is controlled automatically.
- 7) Station remote monitoring equipment shall be provided by Generating Solutions,

GENERATING SOLUTIONS, LLC
1646 West Highway 160, Suite E
Ft. Mill , SC 29708
Tel: 704-904-9461
Fax: 803.548.3854
rdawson@generatingsolutions.net
www.generatingsolutions.net

and shall include all related hardware including backup battery, battery charger, external antenna, and necessary cables, wiring, and circuit overload protection: The monitoring equipment shall receive input from the dry contacts listed in Paragraph 11-04, I. 2) i. above.

8) Motor Branch Components:

- a. Mounting: All motor branch components shall be of the highest industrial quality, securely fastened to a removable sub-plate with screws and lockwashers. The sub-plate shall be tapped to accept all mounting screws. Self-tapping screws shall not be used to mount any components.
- b. Circuit Breaker and Operating Mechanisms: A properly sized heavy duty air circuit breaker shall be furnished for each pump motor, and shall have a symmetrical RMS interrupting rating as noted on the drawings. All circuit breakers shall be sealed by the manufacturer after calibration to prevent tampering.
- c. A padlocking operating mechanism shall be installed on each motor circuit breaker. Operating handles for the mechanisms shall be located on the exterior of the control compartment door, with interlocks which permit the door to be opened only when circuit breakers are in the OFF position.
- d. Motor Starters: An open frame, across-the-line, NEMA rated magnetic motor starter shall be furnished for each pump motor. Starters of NEMA size 1 and above shall be designed for addition of at least two auxiliary contacts. Starters rated "O", "OO", or half size are not acceptable. Power contacts shall be double-break and made of cadmium oxide silver. All motor starters shall be equipped to provide under-voltage release and overload protection on all three phases. Motor starter contacts shall be easily replaceable without removing the motor starter from its mounted position. Acceptable starters are Furnace, GE, Square D or Westinghouse.

J. Variable Frequency Drives (VFDs). The following is a general specification for VFDs which may be used to power 3-phase motors from a single phase commercial power source. Refer to Section 11-02 B. 13).

- 1) This section provides specification requirements for Single Phase Input, solid-state, pulse-width modulated (PWM) Adjustable Frequency Drives, herein referred to as AC Drives, for use with NEMA® design B AC motors, or standard IEC motors.
- 2) Referenced Standards:

ANSI®/NFPA® 70 - National Electrical Code® (NEC®).

UL 508 - UL Standard for Safety Industrial Control Equipment.
UL 508C - UL Standard for Safety Power Conversion Equipment.
NEMA ICS7 : Industrial Control and Systems Variable Speed Drives
IEC 1800 : Adjustable speed Electrical power drive systems
SEMI-F47: Voltage Ride Thru

- 3) Submittals shall include VFD manufacturers standard operation manual and any applicable unit schematics.
- 4) Design Criteria
 - a. The drive should be a PWM (Pulse Width Modulated) transistorized inverter using IGBT's (Insulated Gate Bipolar Transistors) and must be fully digital.
 - b. The drive shall utilize Insulated Gate Bipolar Transistor (IGBT's) in its power section.
 - c. Input Filtering Section shall include a built-in RF/EMI filter for the single phase 200-240V units.
 - d. Rectifier Section that shall include diode bridge rectifier to convert AC to DC.
 - e. DC Filtering Section shall include capacitors to eliminate "ripple" affect on the DC bus to produce smooth DC bus voltage.
 - f. Switching Section that shall included Insulated Gate Bipolar Transistors (IGBT) to provided Pulse Width Modulation.
 - g. The AC drive shall have a user interface (keypad) that presents information in plain English text.
 - h. The AC Drive power converter shall be UL Plenum rated.
- 5) Ratings and overload capability of the VFD
 - a. The drive main input power shall be:
Single-phase 208-240VAC 50/60Hz
Single-phase 400-480VAC 50/60Hz
 - b. The drive shall have a tolerance for voltage +10%, -15% and frequency $\pm 5\%$.
 - c. The drive overload current shall be 100% continuous and 150% for 1 minute.
 - d. The drive manufacturer shall indicate all requirements for input or

output reactors.

- e. The efficiency of the AC Drive at 100% speed and load shall not be less than 97%.

6) ENVIRONMENTAL RATINGS

- a. The AC Drive shall meet IEC 60664-1 Annex A and NEMA ICS 1, UL standards.
- b. The AC Drive shall be designed to operate in an ambient temperature from -10 to 50 °C (14 to 122 °F).
- c. The maximum relative humidity shall be 95%, non-condensing.
- d. The AC Drive shall be rated to operate at altitudes less than or equal to 3300 ft (1000 m).
- e. The AC Drive shall meet the IEC 60721-3-3-3M3 operational vibration specification

7) PROTECTION

- a. Upon power-up, the AC Drive shall automatically test for valid operation of memory, loss of analog reference input, loss of communication, DC-to-DC power supply, control power and pre-charge circuit.
- c. The AC drive shall be rated for UL minimum short circuit currents per given horsepower rating.
- d. The AC Drive shall be protected against short circuits, between output phases and to ground.
- e. The AC Drive shall have under-voltage power-loss ride through performance per the SEMI F-47 voltage ride through standard and certified by a third party.
- f. The AC drive shall have a programmable ride-through function, which will allow the logic to maintain control for a minimum of one-second (60 cycles) without faulting.
- g. An auto restart function will provide selectable time for restart attempts after the fault has disappeared and other operating conditions permit the restart. The restart shall be performed by a series of automatic attempts separated by increasingly longer periods of time. This period of time shall be selectable.

- h. Upon loss of the analog process follower reference signal, the AC Drive shall be programmable to display a fault.
- i. The AC Drive shall have a solid-state UL 508C listed overload protective device and meet IEC 60947.
- j. The output frequency shall be software enabled to fold back when the motor is overloaded.
- k. There shall be two skip frequency ranges that can be programmed to a bandwidth of ± 2.5 Hz.

8) ADJUSTMENTS & CONFIGURATIONS

- a. The AC Drive shall be capable of storing the configuration in the keypad.
- b. The acceleration and deceleration ramp times shall be adjustable from 0.05 to 999.9 seconds.
- c. The memory shall retain and record run status and fault type of the past eight faults that tripped the drive.

9) KEYPAD DISPLAY INTERFACE

- a. A keypad display interface shall offer the modification of AC Drive adjustments through a touch keypad. All electrical values, configuration parameters, I/O assignments, application and activity function access, faults, local control, and adjustment storage, and diagnostics shall be accessible.
- b. The AC Drive model number, torque type, software revision number, horsepower, output current, motor frequency and motor voltage shall be listed on the drive identification portion of the LCD display.
- c. The keypad display shall have password protection that allows the keypad to be locked out from unauthorized personnel.
- d. The keypad shall be capable of displaying I/O assignment and status.

- 10) Warranty: The drive manufacturer shall guarantee the operation of the drive against failure due to defects for 18 months after shipment or 12 months of sale to the user, whichever comes first.

K. Alarms:

- 1) High Pump Temperature Protection: Each control panel shall be equipped with circuitry to override the level control system and shut down the pump motor(s) when required to protect the pump motor from damage caused by excessive temperature. A thermostat shall be mounted in each motor to detect its temperature, and a single relay shall be supplied for each thermostat. If the pump motor temperature should raise to a level which could cause damage, the thermostat shall cause the signal relay to drop out of the motor starter. An red electrical indicator LED, visible on the front of the control panel, shall indicate that the pump motor has been stopped because of a high temperature condition. The pump shall remain locked out until the pump has cooled and the circuit has been manually reset. Automatic reset of such a circuit shall not be acceptable.
 - 2) High Water Alarm: When the wet well level reaches a preset high water level, a switch shall energize a signal relay circuit to visibly indicate such on the front of the control panel. The relay shall maintain the signal until manually reset.
- L. Wiring: The pumping system as furnished by the manufacturer shall be completely wired, except for the power feeder lines to the panel main disconnect, final connections to remote alarm devices, pumps, and level switches. The Contractor shall be responsible for all interconnecting wiring and conduit.

All wiring, workmanship, and schematic wiring diagrams shall be in compliance with applicable standards and specifications set forth by the National Electrical Code (NEC).

- 1) Wire Identification and Sizing: Control circuit wiring inside the panel, with the exception of internal wiring of individual components, shall be 16 gauge minimum, Type MTW or THW, 600 volts. Wiring in conduit shall be 14 gauge minimum. Motor branch wiring shall be 10 gauge minimum.

Motor branch conductors and other power conductors shall not be loaded above 75° C temperature rating. Wires shall be clearly numbered at each end in conformance with applicable standards. The numbering on each wire shall correspond to a similar number on the terminal strip to which the wire is connected. All wire connectors in the control panel shall be of the ring tongue type with nylon insulated shanks. All wires on the sub-plate shall be bundled and tied. All wiring outside the panel shall be in conduit.
- 2) Wire Bundles: Control conductors connecting components mounted on the panel enclosure door shall be bundled and tied in accordance with good commercial practice. Bundles shall be made flexible at the hinged side of the enclosure. Adequate length and flex shall be allowed so that the door can swing to its full open position without undue mechanical stress or abrasion on the conductors or insulation. Bundles shall be clamped and held in place with mechanical fastening devices on each side of the hinge.

M. Power Supply: All stations shall be provided with a control power transformer, single phase primary, to 120 volts/1 ph/60 hertz secondary. Transformer shall be rated for the loads of the lights, alarms and control power. Power service for the pump motor circuits shall be as indicated on the pump data sheets.

N. Pipe, Fittings, Pressure Gauges, and Valves:

- 1) All wet well and valve pit piping and fittings shall be ANSI B16.1 125 lb. standard flange fitted. Pipe and fittings shall be of ductile iron construction and of the sizes indicated on the plans, minimum 4-inch diameter where sizes are not shown. All flange gaskets shall be 1/8" thick full face red rubber. Pipe supports shall be provided as needed.
- 2) Check valves shall be Mueller or Darling swing check type with outside lever and spring.
- 3) Resilient seat gate valves shall be Mueller or Darling.
- 4) Provide a female quick-disconnect fitting for bypass with a gate valve to isolate flow. Quick disconnect should be of a "cam-lock" style, which is, compatible with that used by the District Maintenance and Construction Department. For protection against freezing, on submersible stations, the gate valve shall be located in the valve vault, with only a short piece of pipe extending above ground, terminating with the camlock fitting.
- 4) Pressure gauges (2 required) shall be mounted in the valve vault (submersible stations) or inside the enclosure (suction-lift stations) on the pump side of each check valve and isolated with a shut-off valve. Each gauge shall be 4.5 inches diameter, liquid filled, with a PSI/head range of approximately 25% greater than the design TDH for the station, accurate to within 1% of range. Gauges shall be mounted to allow pressure sensing piping to be cleaned without removing the gauge.

O. Access Hatches:

- 1) The wet well and valve pit access hatches in non-traffic areas shall be constructed of 1/4" aluminum checker plate with all stainless steel hardware, upper guide holder and lifting cable or chain holder.
- 2) Hatches shall be designed for a minimum load of 300 psf. and shall be provided with a metal fall protection grating. Fall protection nets or other fabric devices are not acceptable.
- 3) Each hatch shall have a "slam-latch" which will lock automatically, with a proprietary release key included. Hatches and fall-protection grating shall be held open in the vertical position by means of a mechanical door prop of corrosion resistant zinc plated or stainless steel design. Props shall catch and

release automatically without the need to pull or adjust any handles or bars.

- 4) Hatch shall be as manufactured by Halliday, Bilco, U.S. Foundry, or approved equal. Refer to CONSTRUCTION DETAIL No.25

P. Brackets, Supports and Miscellaneous Metal Parts shall be 316 stainless steel and provided as needed to support piping, floats, controls and their equipment for a complete installation.

- 1) All anchor bolts shall be 316 series stainless steel and shall be secured using the Hilti RE-500 Injection Epoxy Anchor System (or equal); embedment depth shall be per the anchoring system manufacturer's guidelines;
- 2) All metal components inside the wetwell (fasteners, brackets, etc.) other than DIP and the pumps themselves, shall be 316 stainless steel;
- 3) An adequately-sized, stainless steel, lifting chain (minimum 3/8") and hook, shall be provided with each pump and shall be attached to a conveniently placed wall bracket at the entrance hatch.

Q. A Control Panel Rack shall be provided as shown in CONSTRUCTION DETAIL No. 27 in addition to the components listed above, the following hardware shall be mounted on the rack:

- 1) A lightning arrestor;
- 2) A volt surge capacitor;
- 3) The meter base box (supplied by Contractor);
- 4) A fusible disconnect switch or main breaker;
- 5) Manual Transfer Switch. Double throw transfer switch, either 100 Amp or 200 Amp, as required, 3 Pole, 240 volt or 460 volt NEMA 3R with field installed grounding kit Square D or equal.
- 6) Generator Receptacle. Male receptacle, 200 Amp, 4 wire, 4 Pole, to mate with Crouse-Hinds No. AR 2041-S22 plug or equal.

R. Potable Water Supply with Backflow Protection:

- 1) A reduced pressure zone backflow preventer shall be installed on the main water supply between the meter and any plumbing connections according to the water purveyor's installation requirements for relief valve discharge, periodic maintenance and freeze protection. Below ground installations of reduced pressure backflow devices are not approved. Above ground installations shall be housed in a "Hot Box" or approved equal. Typically, most installations shall be located 1' to 2' within the fenced area for the pump

station site and upstream of the hose bibb location. Alternate location for backflow preventer shall be coordinated and approved with the District's Engineering Field Technician (EFT).

- 2) The reduced pressure zone backflow preventer device shall be a Watts 909 or 009, or approved equal.
- 3) A 120V, 20amp, GCFI receptacle, in a weather-proof cover, shall be provided within the backflow preventer enclosure, and a thermostatically-controlled "heat tape" wrapped around the backflow device and piping to prevent freezing.
- 4) A Woodford Iowa Model Y34 (or approved equal) yard hydrant shall be provided in the location shown on the plans or as directed by EFT.

S. Control Panel Canopy (Submersible Stations Only)

- 1) A canopy shall be installed over the submersible pump station control panel as shown in CONSTRUCTION DETAIL NO. 27;
- 2) The canopy structure shall be designed for a minimum 70MPW wind load and shall be equipped with two 4' fluorescent lights which are operated by a weather-proof toggle switch.
- 3) The canopy shall be as supplied by Greer Awning and Siding, or approved equal.

T. Spare Parts

- 1) Submersible pumps shall be supplied with the following spare parts (for one pump):
 - a. One set of upper and lower bearings;
 - b. One replacement mechanical seal;
 - c. O-ring seal kit;
- 2) Suction-lift pumps shall be supplied with the following spare parts (for one pump):
 - a. One replacement mechanical seal;
 - b. O-ring seal kit;

11-05 INSTALLATION:

The station and valve vault shall be installed level and plumb by the Contractor on a bed of stone in accordance with the manufacturer's recommendations, as shown on the plans and described herein. Elevations shall conform to those shown on plans to within $\pm .02$ feet.

- A. Wet well sections shall be handled and installed in such a manner and by such means as to prevent damage. All sections damaged during handling will be and replaced at no additional cost to the Owner. All lifting holes shall be plugged and sealed watertight as recommended by the manufacturer. Wet well base shall be installed on a firm 12-inch washed stone foundation so prepared to prevent settlement and misalignment.
- B. Wet well sections shall be installed plumb and with all pipe holes at the proper elevation.

Riser Sections of the wet well shall be installed using butyl rubber sealant between sections for a water tight connection, in the same manner as for manholes. Refer to SECTION 3. In addition to the butyl rubber sealant, riser sections and flat slab top shall be sealed inside and outside, above and below water level by application of non-shrink grout at all joints for the entire circumference.

Wet well shall be tested for exfiltration by filling up with water to a level 2 feet below the top of the flat slab and measuring the amount of drop over one hour. Exfiltration shall not exceed 0.45 gallons per foot diameter per foot depth per day;

- C. Valve vault shall be installed on a firm 6-inch washed stone foundation so prepared as to prevent settlement and misalignment. The valve vault floor shall be built to provide positive drainage to the wet well. Steps shall not be installed in the valve vault. The valve vault hatch shall be large enough and positioned such that all the following can be performed without climbing into the vault:
- 1) Valve operation
 - 2) Observation of Pressure Gauges
 - 3) Connection of bypass piping to the male quick-connect coupling.
- D. Pumps and piping shall be installed in accordance with the written instructions provided in the shop drawings and indicated on the plans;
- 1) The manufacturer shall furnish such detailed instructions as may be required for proper installation.
 - 2) The manufacturer shall also furnish the services of a qualified service representative to inspect equipment installation, make minor adjustments and place equipment in permanent operation. The manufacturer's representative shall provide whatever items required to insure proper installation, operation

and instruction. Service shall be not less than one day and shall include inspection, minor adjustments, initial operational services and initial instruction.

- E. Lifting Cables shall be cut off flush to finish grade after installation.
- F. Painting: The pumps and equipment shall be supplied with the manufacturer's standard factory-applied finish.
- G. Wiring and conduit required between the control panel and the wet well and to devices located on the electrical service pole shall be provided by the Contractor according to the drawings.
- H. All site work including driveway, fencing, stone and drainage contours shall be provided by the Contractor and as detailed on drawings.
- I. After installation and cleaning up of construction debris, wet well shall be provided with water sufficient to provide start up and pump down tests as necessary to verify pump operation and efficiency for as long a period of time as necessary to accomplish such tasks.

11-06 PUMP STATION FENCING

A. MATERIAL:

All fencing, unless otherwise shown or specified shall be Class 2 Fencing, chain link type, 6 feet high, with zinc-coated (galvanized) fabric, three strands of barbed wire at the top of the fence and gates, and galvanized steel posts, as manufactured by Merchants Metals, Houston TX, or approved equal.

- 1) Fabric shall be 9 gage steel wire woven in 2-inch mesh, with zinc coating conforming to ASTM A392 with the coating weight 2.0oz. per sq. ft. of surface, and twisted at one salvage and knuckled at the other.
- 2) Barbed wire shall consist of two 12 gage steel stranded line wires with 14 gage steel wire barbs in 4 point pattern spaced 5 inches apart. Barbed wire shall be zinc coated (galvanized), minimum weight 1.2 oz. per sq. ft. of surface.
- 3) Posts, rails and appurtenances shall be hot dip galvanized with a minimum 2.0 oz. per sq.. ft. of surface.
- 4) Line Posts shall be 2.5-inch OD Schedule 40 steel pipe.
- 5) Terminal Posts shall be 2.876-inch OD Schedule 40 steel pipe, or 3.5 x 3.5-inch steel roll-formed sections, nominal weight 5.14 lbs. per ft.
- 6) Gate Posts shall be 4.00" OD, Schedule 40 steel pipe as specified below:

- 7) Top rail shall be 1.625 OD steel pipe, Schedule 40 or 1.625 x 1.25 inch steel channel sections, and provided with outside sleeve type couplings every 20 feet.
- 8) Top rail shall pass through line post tops to form a continuous brace from end to end of each stretch of fence. Top rail shall be fastened to terminal posts by heavy pressed steel connections.
- 9) Braces shall be of the same material as the top rail, and shall be installed midway between the top rail and the ground and extending from the terminal post to the first line post. Braces shall be securely fastened to posts by heavy pressed steel connections, then trussed from the line post back to the terminal post with a 3/8-inch diameter rod.
- 10) All fittings used in the complete fence assembly shall be cast iron or pressed steel and shall be zinc coated (galvanized) with a minimum of 1.2 oz. per sq. ft.
- 11) All posts shall be provided with caps, made of cast iron or pressed steel and shall be zinc coated (galvanized) with a minimum of 1.2 oz. per sq. ft. designed to exclude moisture from the posts.
- 12) Tension Arms shall be cast iron or pressed steel, zinc coated (galvanized) with a minimum of 1.2 oz. per sq. ft. and shall be designed to carry three strands of barbed wire at a 45° angle, with the top strand 12 inches above the fabric and 12 inches out from the fence line.
- 13) Gates. Access to the pump station enclosure shall be via a 2-leaf gate providing a clear entrance a minimum of 20' in width.
 - a. Gate Frame: Schedule 40 steel pipe, 1.9 inches OD, welded at corners or assembled with fittings.
 - b. Gate Hardware: Fork-type latch with gravity drop, center gate stop and drop rod, mechanical keepers, and two 180 degree gate hinges per leaf.
 - c. All gate hardware and fittings shall be zinc coated (galvanized) with a minimum of 1.2 oz. per sq. ft.

B. INSTALLATION:

- 1) Line posts shall be evenly spaced at intervals not exceeding 10 feet, and in true alignment with the fence line.
- 2) All posts shall be set plumb at least 36 inches deep in 2500 psi concrete footings, footings shall be not less than 10-inch diameter for line posts and 12-

inch diameter for terminal and gate posts. Top of footings shall be slightly rounded for water runoff.

- 3) Fabric shall be securely fastened to terminal posts by tension bars with pressed steel bands spaced 14 inches apart, to line posts with 6 gage wire clips spaced 14 inches apart and to the top rail with 9 gage tie wires spaced 24 inches apart.
- 4) Barbed wire shall be properly stretched and securely fastened to extension arms and gate posts.
- 5) Extension Arms shall be installed with the arms inclined outward.
- 6) Gates shall be installed with fabric and barbed wire overhang to match fence. Fabric shall be securely fastened to the frame. Diagonal truss rods shall be provided as required to prevent sag or twist. Gates shall be properly installed with all hardware and accessories to insure that they open and close freely without binding. A 2500 psi concrete footing at least 1 inches deep and drop rod retained shall be provided at the center of double gate openings.

11-07 QUALITY ASSURANCE AND CERTIFICATION:

- A. Final Certification: After installation and final testing of equipment and instrumentation, the manufacturer furnishing supervision and/or inspection services shall make written certification to both the Design Engineer and the District that his equipment and the controls have been properly installed and operate in accordance with the specifications and drawings, and that the operating and maintenance instructions have been furnished to the District.
- B. Warranty: The station manufacturer shall warranty the complete pump station and all equipment provided to be free from defects in materials and workmanship for one year from the date it is placed in permanent operation by the manufacturer's representative. Warranty shall include 100% coverage of the manufacturer's labor, materials and equipment to remove and replace defective materials and workmanship at no cost to the Owner.
- C. Pump Warranty: The pump manufacturer shall warranty the pumps supplied to the Owner for a period of five (5) years under normal use. The warranty must include 100% coverage of the manufacturer's shop labor and parts including bearings, seals and stators for the first year from the date the station was placed in operation, and then prorated coverage not excluding bearings, seals and stators, through the 5th year.

SECTION 12

INSPECTION AND TESTING

12-01 SCOPE

- A. All work shall be subject to inspection and approval prior to final acceptance for Operation and Maintenance (O&M) by the Spartanburg Sanitary Sewer District, hereinafter referred to as the "District".
- B. All testing shall be performed in the presence of the Engineer of Record or his representative and the District's Engineering Field Technician (EFT).
- B. This section includes testing of gravity sewer lines, manholes and sewer force mains. Pump station testing is covered in SECTION 11 of these Specifications.

12-02 GRAVITY SEWER LINE TESTING

A. VISUAL

Gravity sewer lines will be lamped or inspected by Closed-Circuit Television (see Section 12-05) and all pipe shall show a true line between manholes without defects in conditions, grade or alignment.

B. INFILTRATION:

All gravity sewer lines shall be checked for the potential for infiltration or exfiltration. All tests shall be conducted under the direction of the Engineer of Record and the District. Any line or manhole which fails the testing shall be repaired or replaced as needed.

- 1) The following test methods are approved by the District:
 - a) Vacuum testing shall be used for manholes and other concrete structures (other than wetwells);
 - b) Low-pressure air testing shall be used for gravity sewer lines;

C. LOW-PRESSURE AIR TEST:

- 1) Air test shall be conducted in strict accordance with the testing equipment manufacturer's instructions, including all recommended safety precautions. No one will be allowed in the manholes during testing. Equipment used for air testing shall be equipment specifically designed for this type of test and shall include: Shut-off valve, pressure regulating valve, pressure reduction valve, monitoring gauge (0 to 5 psi with minimum divisions of 0.10 psi or approved by the EFT), air compressor and plugs.

- 2) After an internal pressure of 4.0 psig is obtained, allow at least two minutes for air temperature to stabilize, adding only the amount of air required to maintain pressure. After stabilization period, adjust the air pressure to 3.5 psig and valve off air supply.
- 3) For ductile iron pipe, the section of the line being tested will be considered acceptable if the time required for a pressure drop of 1.0 psig is more than the time shown for each pipe size in the following table:

<u>Pipe Diameter</u> <u>(Inches)</u>	<u>Time/100 Ft.</u> <u>(Min. : Sec.)</u>
4 -----	0:18
8 -----	1:12
10 -----	1:30
12 -----	1:48
15 -----	2:06
18 -----	2:24

- 4) For PVC pipe determine the time in seconds that is required for the internal air pressure of 3.5 psig to reach 3.0 psig. Minimum permissible pressure holding time required for pressure to drop from 3.5 psig to 3.0 psig shall be as on the Air Test Table 12-A.

Table 12-A

**SPECIFICATION TIME REQUIRED FOR A 0.5 PSIG PRESSURE DROP
FOR SIZE AND LENGTH OF PIPE INDICATED FOR Q = 0.0015**

1 Pipe Dia. (In.)	2 Min. Time (Min: Sec.)	3 Length For Min. Time (Ft.)	4 Time For Longer Length (Sec.)	Specification Time for Length (L) Shown (Min:Sec)								
				100 Ft.	150 Ft.	200 Ft.	250 Ft.	300 Ft.	350 Ft.	400 Ft.	450 Ft.	
4	1:53	597	.190L	1:53	1:53	1:53	1:53	1:53	1:53	1:53	1:53	1:53
6	2:50	398	.427L	2:50	2:50	2:50	2:50	2:50	2:50	2:51	3:12	3:12
8	3:47	298	.760L	3:47	3:47	3:47	3:47	3:48	4:26	5:04	5:42	5:42
10	4:43	239	1.187L	4:43	4:43	4:43	4:57	5:56	6:55	7:54	8:54	8:54
12	5:40	199	1.709L	5:40	5:40	5:42	7:08	8:33	9:58	11:24	12:50	12:50
15	7:05	159	2.671L	7:05	7:05	8:54	11:08	13:21	15:35	17:48	20:02	20:02
18	8:30	133	3.846L	8:30	9:37	12:49	16:01	19:14	22:26	25:38	28:51	28:51
21	9:55	114	5.235L	9:55	13:05	17:27	21:49	26:11	30:32	34:54	39:16	39:16
24	11:20	99	6.837L	11:24	17:57	22:48	28:30	34:11	39:53	45:35	51:17	51:17
27	12:45	88	8.653L	14:25	21:38	28:51	36:04	43:16	50:30	57:42	64:54	64:54
30	14:10	80	10.683L	17:48	26:43	35:37	44:31	53:25	62:19	71:13	80:07	80:07
33	15:35	72	12.926L	21:33	32:19	43:56	53:52	64:38	75:24	86:10	96:57	96:57
36	17:00	66	25.384L	25:39	38:28	51:17	64:06	76:55	89:44	102:34	115:23	115:23

D. DEFLECTION TESTING:

- 1) After installation and backfilling all PVC, pipe shall be tested for deflection.
- 2) Deflection testing shall be performed a minimum of 30 days after installation and backfilling;
- 3) Lines shall be thoroughly cleaned prior to testing to insure accurate testing. The mandrel which is used for testing shall be a commercially-available item designed to comply with ASTM D2321. Either the Aluminum Fin Style or the Fixed Aluminum or Steel mandrel designs (as manufactured by the Cherne Industries, Lincoln, Nebraska, or equal) are acceptable. Refer to Table 12-B for which shows the average PVC sewer pipe ID and the 5% Deflection.

Table 12-B: Acceptable Deflection for PVC Sewer Pipe

Nominal Pipe Size	Pipe	Base ID*	5% Deflection
8"	SDR-35	7.665	7.28
10"	SDR-35	9.563	9.08
12"	SDR-35	11.361	10.79
15"	SDR-35	13.898	13.2
18"	SDR-35	16.976	16.13
21"	SDR-35	20.004	19.00
24"	SDR-35	21.964	20.87
27"	SDR-35	25.327	24.06

*Base Inside Diameter (Base ID) - Allows for out of roundness and wall thickness tolerances as defined by ASTM Standards D3034 and F679 for PVC Sewer Pipe

- 4) Deflection test record shall identify the location and deflection amount at all points where deflection exceeds 5%. Pipe with initial deflection exceeding 5% will be unacceptable, and shall be rebudded to the correct deflection and retested for deflection;
- 5) The following procedure shall be used in testing PVC or other non-rigid sewer pipeline:
 - a) The pipeline to be tested must be clean and free of debris that might cause the mandrel to jam. It is recommended that the line be cleaned with a hydrocleaner, washing in the direction of flow. Cleaning water shall not be discharged to existing sewer lines.
 - b) The mandrel shall be placed in the pipeline and pulled from manhole section to manhole section using one of the following methods:
 - i. The pulling shall be done by hand, with a smooth and easy pull to avoid jamming the mandrel if an obstruction is encountered

in the line. The mandrel should have a tow line on each end to facilitate removal should the mandrel become obstructed in the direction of pull. If the mandrel stops, lightly pull on it to see if it will clear the obstruction. When it appears that the mandrel will not go forward, record the distance from the manhole at which the mandrel is stuck and then pull the mandrel back.

- ii. The mandrel may be propelled through the pipe using a “parachute” device which is acted upon by the flow of air from a high-volume, low pressure air blower. The blower is placed over the forward manhole and draws air through the pipe being tested. The parachute is attached to the front of the mandrel, and a tow line connected to the rear, to retrieve the mandrel if it encounters an obstruction. The flow of air from the blower must be sufficient to inflate the parachute and transport the mandrel.

NOTE: The two methods listed above are the only approved methods for performing the mandrel testing. Under no circumstances shall the mandrel be pulled by any mechanically-powered device, such as a hydraulic or electric winch or windlass, which could generate a greater pulling force than the manual method and which could deform the mandrel. The EFT shall have final approval of the method of mandrel testing.

- c) A record of the testing, and retesting if necessary, shall be retained by the District’s EFT. The Engineer’s or his representative shall be responsible for retaining their own copy of the test results for submission to SCDHEC if necessary.

12-03 MANHOLE TESTING

- A. Manholes shall be true circles of acceptable concrete or masonry work with properly corbeled tops, satisfactory inverts and properly placed frames, covers and steps.
- B. Vacuum Testing: All manholes shall be subjected to a vacuum test. The Contractor will furnish all necessary equipment and labor needed for conducting the tests. The Contractor shall have the option to test manholes prior to backfilling. Preparation and testing of manholes shall be as follows:
 - 1) All mortar joints shall be adequately cured;
 - 2) Pipes entering and leaving the manhole shall be plugged;
 - 3) Draw a vacuum of 10 inches of HG (Mercury).

- 4) The test shall pass if the vacuum drops to no less than 9 inches HG in 1 minute.
- 5) If the manhole fails the test, the Contractor shall locate the leak(s), make proper repairs, and then re-test until a successful test is obtained.

12-04 FORCE MAIN TESTING

A. HYDROSTATIC TESTING:

- 1) General
 - a) Clean and flush line of dirt and foreign material.
 - b) Do not perform hydrostatic tests until at least 24 hours after installation of concrete thrust blocking.
 - c) Provide temporary plug and blocking at open ends.
 - d) The Contractor shall provide an approved test pump and a method of measuring water pumped into the pipeline which is acceptable to the Engineering Field Technician
- 2) The District Engineering Field Technician shall connect the Pressure Test Recording Device to an appropriate pressure tap on the force main, shall operate the device, and shall be present during the entire test.
- 3) The test pressure shall be 1.5 times the working pressure of the line or 150 psi, whichever is greater, as measured at the lowest point in the section of the line being tested, and no less than 1.25 times the working pressure as measured at the highest point in the section.
- 4) The pressure in the line shall be pumped up to the test pressure and be constantly maintained for 96 minutes and recorded on Pressure Recorders furnished by the District. During testing, the pressure must be maintained to within ± 5 psi of the test pressure.
- 5) Leakage is the quantity of water that must be supplied to the newly laid pipe or any closed-valved section to maintain the pressure within the limits stated above.

- 6) The allowable leakage (for DIP and PVC) is defined by the following AWWA formulas:

Ductile Iron Pipe

$$L = \frac{SD/P}{133200}$$

where

L = Allowable leakage in gallons per hour

S = Length of pipe in feet

D = Diameter of the pipe in inches

P = Average test pressure in psi

PVC Pipe

$$L = \frac{ND/P}{7,400}$$

where

L = Allowable leakage (gallons per hour)

N = # of joints in the length of pipe being tested

D = Nominal diameter of pipe (inches)

P = Average test pressure during the leakage test (psi)

- 7) NOTE: The formulas above do not apply to pressure testing of HDPE pipe. HDPE pipe shall be hydrostatically tested by following the manufacturer's procedures. Only hydrostatic (water pressure) testing is approved by the District; air pressure testing shall not be performed.
- 8) If the amount of leakage exceeds the allowable limit, the Contractor shall locate and repair the leaks and shall retest the line using the same test procedures. All visible leaks shall be repaired regardless of the amount of leakage.

12-05 CCTV INSPECTION

Summary: This section includes internal Closed Circuit Television (CCTV) inspection of sewers. Sewer interiors shall be inspected using color closed-circuit television (CCTV) camera, and document inspection on Digital Video Disk (DVD) with audio location and date information, DVD title information, and continuous tape counter. A hard copy of inspection log shall be provided.

A. QUALIFICATIONS

- 1) The CCTV equipment shall be operated by personnel who have been trained and certified in the particular equipment used.

- 2) The DVD audio track commentary shall be produce by personnel experienced and certified in locating breaks, obstacles, service connections, and other main sewer features by closed circuit television. The Pipeline Assessment Certification Program (PACP) administered by the National Association of Sewer Service Companies (NASSCO), or a similar program shall be consider the minimum qualification for the CCTV technician.

B. SUBMITTALS

- 1) Submit training records and certificates for all personnel involved in the CCTV work.
- 2) Quality Assurance: Submit one example DVD of previous sewer inspection work that shows operational and structural defects in sewers, complete with audio commentary and inspection log(s). Prior to submitting, finalized the DVD to prevent re-recording.
- 3) DVD and Inspection logs will be reviewed to determine if quality of CCTV image is acceptable, and if defects were properly identified and documented according to District requirements.
- 4) Modify equipment and/or inspection procedures to achieve report material of acceptable quality.
- 5) Do not commence Work prior to approval of report material quality by the District. Upon acceptance, report material shall serve as standard for remaining Work.

C. Inspection Logs: Unless otherwise indicated, submit inspection logs that include the following as a minimum:

- 1) Title: Project Name and District Project Number
- 2) "Performed for the Spartanburg Sanitary Sewer District"
- 3) Time of day
- 4) Manhole ID (from GIS)
- 5) Manhole to manhole pipe section
- 6) Pipe segment length
- 7) Pipe material
- 8) Line size
- 9) Compass direction of viewing Direction of camera's travel
- 10) Pipe depth
- 11) Operator name
- 12) Tape counter reading at beginning and end of each manhole to manhole pipe segment.

C. DVDs; must be in a format readable with standard viewing software such as Windows Media Player. If a specific software program is needed, please submit a copy of the software for preapproval.

D. Maintain copy of all inspection documentation (DVDs, databases, and logs) for duration of Work and warranty period.

E. PRODUCTS

1) MATERIALS AND EQUIPMENT

- a. DVD: 120 minute, minimum, high-quality color, type DVD-R, DVD-RW, or DVD+R
- b. Audio portion of composite DVD shall be sufficiently free from electrical interference and background noise to provide complete intelligibility of the oral report.
- c. Store in upright position with temperature range of 45 to 80 degrees F (7 to 27 degrees C) in an appropriate CD or DVD case to prevent scratches.
- d. Identify each DVD with tape labels showing District's name, Contractor's name, and each manhole-to-manhole pipe segment of sewer line represented on DVD or provide an Index or Table of Contents if more than one segment is on the disk.
- e. DVD Titling: Each segment shown on the DVD should have its own Chapter titled with the beginning and end point of the pipe segment;
- f. Television Inspection Camera(s):
 1. Equipped with rotating head, capable of 90-degree rotation from horizontal and 360-degree rotation about its centerline;
 2. Minimum Camera Resolution: 400 vertical lines and 460 horizontal lines.
 3. Focal Distance: Adjustable through range of 6 inches (152 mm) to infinity.
 4. Camera(s) shall be intrinsically safe and operative in 100 percent humidity conditions.
 5. Lighting Intensity: Remote-controlled and adjustable to minimize reflective glare.
 6. Lighting and Camera Quality: Provide clear, in-focus picture of entire inside periphery of sewer.
 7. Footage Counter: Measures distance traveled by camera in sewer, accurate to plus or minus 2 feet (0.6 m) in 1,000 feet (305 m).

F. SEWER FLOW REQUIREMENTS

- 1) Do not exceed depth of flow shown in Table 1 for respective pipe sizes as measured in manhole when performing TV inspection.
- 2) When depth of flow at upstream manhole of sewer line section being worked is above maximum allowable for TV inspection, District may require that the

flow be reduced to level shown in Table 12-C, by plugging or blocking of flow, or by pumping and bypassing of flow as specified.

TABLE 12-C: Maximum Depth of Flow for TV Inspection

Nominal Pipe Diameter	Maximum Depth of Flow
6" – 10"	20 percent of pipe diameter
12" - 24"	25 percent of pipe diameter

G. SEQUENCE OF WORK

- 1) Perform Work in the following sequence:
 - a. Clean sewer lines and manholes as needed to allow free travel of the camera.
 - b. Perform TV inspection to comply with requirements of this specification.

H. INSPECTION REQUIREMENTS

- 1) Access: The District Engineering Field Technician, or other District Representative, shall have access to observe monitor and other operations at all times.
- 2) DVD Commentary: Record the following information on audio track of inspection : DVD narrative of location, direction of view, manhole numbers, pipe diameter and material, date, time of inspection, and location of laterals and other key features.
 - a. DVD shall visually display this information at beginning and end of each manhole-to-manhole pipe segment.
 - b. DVD between manholes shall visually display length in feet from starting point of given segment.
- 3) Sewer Identification: DVD and inspection documentation shall include sewer line and manhole identifiers from the District's GIS (if available).
- 4) Image Perspective: Camera image shall be down center axis of pipe when camera is in motion.
 - a. Provide 360-degree sweep of pipe interior at points of interest, to more fully document existing condition of sewer.
 - b. Points of interest may include but are no limited to the following: defects, cracks, voids, connections, encrustations, mineral deposits, debris, sediment, and any location determined not to be clean or part of an improper liner installation.
 - c. Cabling system employed to transport camera and transmit its signal shall not obstruct camera's view.
- 5) Sewer Reach Length: Physically measure and record length of each sewer

reach from centerline of its terminal manholes.

- 6) Inspection Rate: Camera shall be pulled through sewer in either direction, but both inspections are to be in same direction. Maximum rate of travel shall be 30 feet (9 m) per minute when recording.

I. FIELD QUALITY CONTROL

District will review videotapes and logs to ensure compliance with requirements listed in this specification.

SECTION 13

GREASE, OIL, and SAND TRAPS or INTERCEPTORS

13-01 SCOPE:

- A. This section covers the requirements for the construction and installation of Grease, Oil and Sand Traps or Interceptors when required by the Spartanburg Sanitary Sewer District, hereinafter referred to as the “District”. As used in the paragraphs below, the term “Interceptor” shall refer to the structure which is designed to separate and hold grease, oil, sand, or other materials from the wastewater stream, to prevent the discharge to the District’s system. These structures are commonly referred to as “grease traps”, “sand traps” or “oil-water separators”.
- B. This section is not intended to be a comprehensive presentation of the District’s policies and procedures related to the control of grease, oil, sand, or other materials which may be prohibited from being discharged to the District’s wastewater collection, transmission or treatment system. The reader is referred to the full text of the “Spartanburg Sanitary Sewer District Grease Control Program”. Please contact the Water Quality Department at 864-253-9632, for additional information and assistance.

13-02 GENERAL PROVISIONS

- A. Grease, Oil and Sand Traps or Interceptors shall be provided when, in the judgment of the District, they are necessary for the proper handling of liquid wastes containing fats, oils, grease or solids which may be harmful to, or cause obstruction of, the publicly owned treatment works, or interfere with the operation of the treatment works.
- B. The following types of facilities will generally require the installation of an Interceptor:
 - 1) Food service establishments with on-site food preparation, including restaurants, public eating places, hospitals, hotels, or other institutions;
 - 2) Vehicular service facilities, garages, automotive repair shops;
 - 3) Car washes;
 - 4) Any other facility which may have the potential to discharge prohibited materials, similar to that produced in the above facilities, into the District system.

C. APPROVALS

- 1) The Design Engineer for the project which will incorporate one or more Interceptors shall clearly show the location of the structure on the project drawings.
 - a. Interceptors shall be located so as to be readily accessible for inspection, cleaning, and maintenance, and shall not be located near main entranceways or drive-through driveways.
 - b. The use of ladders or the removal of bulky equipment in order to inspect or service interceptors shall not be acceptable.
- 2) Depending on the complexity of the project, District may require that the Design Engineer provide a copy of the building plumbing plans for review, to confirm that the following fixtures are connected to the Interceptor:
 - a. All drains from the kitchen, food preparation and dishwashing areas;
 - b. Garbage grinders;
 - c. Wash-down area floor drains;
 - d. Car wash discharges.
 - e. All other floor drains

Sanitary fixtures such as toilets, urinals, bathroom sinks, etc. shall not be connected to the interceptor.
- 3) The size, type, and location and piping detail of each Interceptor shall be included on the project drawings, and shall be approved and inspected by the District.
- 4) Interceptors shall be no less than 1,000 gallons total capacity unless otherwise approved by the District.
- 5) At a minimum, Interceptors shall be designed to provide 30 minutes retention time at peak flow conditions.
- 6) Under-Counter Interceptors
 - a. For cases in which below ground-type grease interceptors are not feasible to install, food service establishments will be required to install adequate and approved "under-the-counter" or "in the floor" grease traps for use on individual fixtures, including pot sinks, mop sinks, pre-rinse sinks, wok

ovens, floor drains, and other potentially grease-containing drains.

- b. In such cases, units will be considered acceptable only if approved flow control fittings are provided to the grease interceptor inlet to prevent overloading of the fixture and to allow for proper interceptor operation.
 - c. Under-counter or in-the-floor interceptors will not be approved if the purpose is to avoid the expense or inconvenience of properly upgrading the sewer service to a building whose original purpose did not include activities which would require the installation of an interceptor.
- 7) Approval of an interceptor installation by the District does not in any way relieve the operator of the facility from the responsibility for, and possible penalties which may result from, a discharge of prohibited material into the District's sewer system.

13-03 MATERIALS

- A. Interceptor Material shall be precast, reinforced concrete, unless otherwise approved by the Design Engineer and the District, and shall conform to ASTM C478;
- B. The Interceptor shall consist of a monolithic base section with either a single compartment or two compartments separated by a baffled wall and a flat slab top section as required, all in accordance with the details shown on the plans. Minimum compressive strength of concrete shall be 4000 psi.
- C. Maximum allowable absorption of concrete shall be 8 percent of the dry mass. Interceptor interior walls, tables and inverts shall be a smooth surface free of voids, depressions, chips, rough edges and high spots.
- D. Pipe openings shall be provided in base section as required. Lifting holes may be provided in the base section and top for ease of handling.
- E. Joint Sealant shall be by butyl rubber ring joint, 1-inch diameter, conforming to Federal Specifications SS-S-00210, Type I. Cement mortar joints will not be acceptable, except that each joint shall be wiped inside the structure with cement mortar after assembly.
- F. Piping and tees installed in conjunction with grease traps shall either PVC or ductile iron and meet the requirements of SECTION 4: GRAVITY SEWER: MATERIALS AND GENERAL INSTALLATION of this document. Influent and effluent pipes must be a minimum of 4-inches in diameter.
- G. Manhole Frame and Cover shall be consistent with the requirements of SECTION 3: MANHOLES of this document.

H. Refer to CONSTRUCTION DETAIL No. 28.

13-04 INSTALLATION

- A. Interceptors: Each section of the Interceptor shall be handled and installed in such a manner and by such means to prevent damage. All sections damaged during handling and installation will be rejected as directed by the Engineer, Engineering Field Technician, or Industrial Wastewater Specialist, and replaced. All lifting holes shall be plugged and sealed watertight as recommended by the manufacturer.
- 1) Interceptors must be installed below grade, be level and must be placed a firm 6-inch washed stone foundation so prepared to prevent settlement and misalignment.
 - 2) Pipe openings shall either be precast or cored at the exact location to receive entering pipes.
 - a. No jack-hammered or chiseled openings shall be permitted.
 - b. If a penetration in the concrete structure has been installed in the incorrect location or elevation, the opening shall be closed with brick and mortar and a new pipe opening cored, subject to the inspection and approval by the District.
 - 3) Pipe Connections shall be made by a flexible synthetic rubber boot mechanically clamped in the opening in the concrete and to the pipe to provide a watertight seal and designed to accommodate pipe movement up to 2 inches radially or 22 degrees angularly in any direction. The synthetic rubber boot shall have a minimum wall thickness of 3/8 inch. The synthetic rubber shall conform to ASTM C-923. Bands, clamps and other accessories shall be of 316 stainless steel.
 - 4) Inlet pipe shall terminate 24 inches above the floor of the structure.
 - 5) Outlet pipe must terminate 12 inches above the floor of the structure;
 - 6) Interceptor access manholes shall be provided over the inlet and outlet. The access manholes shall extend at least to finished grade and be designed to enable visual inspection of the tees. Joint sealant must be of the specified type.
 - 7) A Vent shall be provided for dual-chambered interceptors that terminates 12-inches above the floor and extends to grade with a clean out plug. In asphalt

or concrete areas, a brass plug must be used. In grass area PVC or brass may be used.

- 8) The Baffle Wall which separates the two chambers of the interceptor shall be located a distance 2/3 of the total length of the interceptor from the inlet wall.
- 9) Interceptor excavation, backfill, and compaction shall conform to the requirements for backfilling trenches, SECTION 6: TRENCH EXCAVATION AND BACKFILL, except that no backfill shall be placed around the structure until all mortar has properly set.

B, Connection to Interceptors

- 1) All drains from the kitchen, food preparation, and dishwashing areas shall be connected to the grease trap. All waste shall enter through the inlet pipe only.
- 2) Toilets, urinals, and similar fixtures shall not waste through the grease trap.

C. All Interceptor installations shall be inspected and approved by the District before being placed in operation. Contact the New Connections Department at 864-580-5629 to schedule inspections.

SECTION 14

WORK INVOLVING EXISTING FACILITIES

14-01 GENERAL

The purpose of this section is to address some of the conditions which may be present at existing Spartanburg Sanitary Sewer District (District) facilities and the requirement that the operation and/or function of most facilities must continue during construction, replacement, or rehabilitation. The following paragraphs are meant to be a general guideline. The District recognizes that each situation is different; however, it shall be the Contractor's responsibility to preserve and maintain the function and integrity of the District's infrastructure, using whatever means are necessary.

14-02 VEHICLE ACCESS

- A. In general, the Contractor shall maintain normal vehicle access to and from all District facilities during all work. Any road closures or other disruptions to the normal flow of traffic shall be submitted to the District for approval a minimum of 3 days prior to the requested dates. Included with this submittal shall be all applicable City, County, Dor State encroachment permits.

- B. Traffic Control
Except as otherwise specified herein, all traffic control activities shall comply with the current version of the Manual on Uniform Traffic Control Devices published by the U.S. Department of Transportation and all applicable State, County or City encroachment permits and local 911 notification requirements.

14-03 BY-PASS PUMPING

- A. During the execution of any work which may require or cause disruption of flow through a pipe, manhole, or other structure, the Contractor shall be responsible for the continuity of sanitary sewer service to each facility connected to the affected section of sewer line.

- B. The Contractor shall indicate to the District the manholes which will be involved with bypass pumping as part of the work;

- C. The District shall provide to the Contractor an estimate of the flow data for the average flows normally observed in the lines identified under item B. above, based on the area served. The District makes no warranty with regard to the accuracy of the data provided, since there are many unforeseeable conditions which may affect the flow in an active sewer line.

- D. The Contractor shall submit a plan for bypass pumping (Bypass Plan) of sewage around the work area and facilities where sewage flows must be interrupted to carry on the work.

- 1) The Bypass Plan shall include the following:
 - a. A sketch of the bypass pumping layout showing the proposed suction and discharge locations, the position of all pumps, piping, generators, etc., and the proposed piping route;
 - b. Specifications for all pumping equipment to be used on the job (including all sizing calculations, pump curves, etc.). The bypass equipment shall be adequate to handle expected peak flows with a minimum 2X margin of safety;
 - c. A list of all backup pumping equipment to be held in reserve on the job site;
 - d. A description of any specialized equipment which may be needed such as bridge piping for driveway access;
 - d. A list of all On-Call personnel who will be able to respond should a problem develop. The Contractor shall provide qualified service personnel who can reach the site within 30 minutes after a high-water or other alarm is activated;
 - 2) Electric primary pumping is acceptable, with 100% redundancy provided in the form of a diesel or other auxiliary backup equipment.
 - 3) An auto-dialer, or other automatic notification equipment shall be provided to notify the Contractor of any problems with the equipment.
- G. The Contractor shall be responsible for all electrical costs for bypass pumping, including the installation of temporary power poles, etc.
- H. The Bypass Plan shall be reviewed and approved by the District before any work is started. Such approval does not guarantee the adequacy of the pumping system. If the proposed bypass system has inadequate capacity to properly transport wastewater around the work area, the Contractor shall take whatever measures are needed to supplement the equipment including larger and/or more numerous pumps and piping.
- I. The Contractor is responsible for insuring that the operation of any mechanical bypass equipment does not violate local noise ordinances. The Contractor shall incorporate whatever noise abatement measures which are needed, including the use of "Quiet Pack" pumps, insulated enclosures, supplemental mufflers on diesel engines, etc.
- J. If, at any time during construction, effluent from the existing sewer is not fully contained by the bypass system, gravity service shall be restored, and the work

suspended until the problem is resolved to the satisfaction of District. This includes wastewater flow into trenches during excavation work. Sewer system overflows will not be tolerated. The Contractor shall be liable for any fines or cleanup costs associated with failures of the bypass pumping system, regardless of the cause or responsible party.

SECTION 15

REHABILITATION AND PROTECTION OF CONCRETE AND BRICK MANHOLES OR UNDERGROUND VAULTS

15-01 SCOPE:

This specification covers work, materials and equipment required for protecting and/or rehabilitating of concrete, brick, and masonry manholes and other underground vaults by the application of appropriate materials to eliminate infiltration, provide corrosion protection, repair voids and deteriorated surfaces and to enhance structural integrity. Procedures for surface preparation, cleaning, application and testing are described herein.

15-02 DESIGN CRITERIA

Reference Standards of the American Society of Testing of Materials (ASTM)

ASTM D638 - Tensile Properties of Plastics.

ASTM D790 - Flexural Properties of Unreinforced and Reinforced Plastics.

ASTM D695 - Compressive Properties of Rigid Plastics.

ASTM D4541 - Pull-off Strength of Coatings Using a Portable Adhesion Tester.

ASTM D2584 - Volatile Matter Content.

ASTM D2240 - Durometer Hardness, Type D.

ASTM D543 - Resistance of Plastics to Chemical Reagents.

ASTM C109 - Compressive Strength Hydraulic Cement Mortars.

ASTM C348 - Flexural Strength Hydraulic Cement Mortars.

ASTM C396 - Compressive Strength of Cement Mortars.

ACI 506.2-77 - Specifications for Materials, Proportioning, Application of Shotcrete.

ASTM C579 - Compressive Strength of Chemically Setting Silicate and Silica Chemical Resistant Mortars.

NACE - The published standards of National Association of Corrosion Engineers (NACE International), Houston, TX.

SSPC - The published standards of the Steel Structures Painting Council, Pittsburgh, PA.

15-03 SUBMITTALS

The following items shall be submitted to the Engineer for approval:

- A. Technical data sheet on each product used, including ASTM test results indicating the product conforms to and is suitable for its intended use per these specifications.
- B. Material Safety Data Sheets (MSDS) for each product used.
- C. Project-specific guidelines and recommendations.
- D. Qualifications of Applicator:
 - 1) Manufacturer certification that the Applicator has been trained and approved in the handling, mixing and application of the products to be used. As used in this document, the term “Applicator” shall be defined as the person actually performing or directing the work on the site, and who is responsible for the proper execution of all work defined in the specifications.
 - 2) Applicator must have not less than three years experience using the specified material;
 - 3) All persons actively involved in the rehabilitation or coating operation, regardless of their level of responsibility, shall have less than two year’s experience in manhole or concrete vault rehabilitation and coating.
 - 4) Certification that the equipment to be used for applying the products has been manufactured or approved by the protective coating manufacturer and that the Applicator personnel have been trained and certified for proper use of the equipment.
 - 5) Contractor shall provide five (5) recent references of indicating successful application to sewer manholes, or other underground concrete structure, of a high-build solventless epoxy coating by plural component spray application;
 - 6) Proof of any necessary federal, state or local permits or licenses necessary for the project, including all OSHA regulations.
- E. Design details for systems and equipment to be used in site and surface preparation, application and testing.
- F. Design details for systems and equipment to be used in site and surface preparation, application and testing.
- G. By-pass Pumping
 - 1) The Contractor shall indicate to the Engineer which manholes will require bypass pumping as part of the work;

- 2) The Engineer shall provide to the Contractor flow data for the average and peak (dry weather) flows normally observed in the lines identified under 7.a. above;
- 3) Refer to SECTION 14 of this document for guidelines and requirements for bypass pumping.

H. Manufacturer Qualifications

- 1) Not less than 5 years of successful experience in supplying principal materials for reconstruction of sanitary sewer manholes of waste water treatment structures;
- 2) Documentation of such experience by reference lists.

J. WARRANTY

- 1) Applicator shall warrant all work against defects in materials and workmanship for a period of ten (10) years, unless otherwise noted, from the date of final acceptance of the project.
- 2) Applicator shall, within a reasonable time after receipt of written notice thereof, repair defects in materials or workmanship which may develop during said ten (10) year period, and any damage to other work caused by such defects or the repairing of same, at his own expense and without cost to the Owner.

15-04 PRODUCTS AND MATERIALS

A. EXISTING MATERIALS

- 1) Standard Portland cement or new concrete (not quick setting high strength cement) must be well cured prior to application of the protective coating. Generally, 28 days is adequate cure time for standard Portland. If earlier application is desired, compressive or tensile strength of the concrete can be tested to determine if acceptable cure has occurred. (Note: Bond strength of the coating to the concrete surface is generally limited to the tensile strength of the concrete itself. Engineer may require Elcometer pull tests to determine suitability of concrete for coating)
- 2) Cementitious patching and repair materials should not be used unless their manufacturer provides information as to its suitability for topcoating with an epoxy coating. Project specific submittals should be provided including application, cure time and surface preparation procedures which permit optimum bond strength with the epoxy coating.

- 3) Remove existing coatings prior to application of the new protective coating. Applicator is to maintain strict adherence to applicable NACE and SSPC recommendations with regard to proper surface preparation and compatibility with existing coatings.

B. REPAIR MATERIALS

- 1) Infiltration control shall be achieved using one of the following methods:
 - a. A premixed, fast-setting, volume-stable waterproof cement plug consisting of hydraulic cement, graded silica aggregates, special plasticizing and accelerating agents may be used. It shall not contain chlorides, gypsums, plasters, iron particales, aluminum powder, or gas-forming agents or promote the corrosion of steel it may come into contact with. Set time (ASTM C-191) shall be approximately 1 minute. Ten minute compressive strength (ASTM C-109) shall be a minimum of 500 psi. Acceptable products shall be:

CEMTEC, manufactured by A.W. Cook, Hoschton, Ga.;

Quadex Quad-Plug, manufactured by Quadex, Inc., Maumelle, Arkansas,

Thoroc Plug manufactured by ChemRex, Shakopee, MN

Approved equal products;
 - b. A silicate-based liquid accelerator, field mixed with neat portland cement. The set time shall be approximately 1 minute.
 - c. The elastomeric polyurethane resin-soaked method, using dry twisted jute oakum, or resin-rod with polyurethane resin (water activated)
 - d. Chemical injection grout sealants which shall be applied according to the manufacturer's recommendations. Acceptable products shall be
 - e. AV-100 Acrylamide Gel, AV-118 Acrylic Gel, or AV-202 Multigrout Urethane Resin manufactured by Avanti International,
 - f. Prime-Flex 900 XLV, Prime-Flex Hydrogel SX, manufactured by Prime Resins, Conyers, GA
 - g. HYDRO ACTIVE Combi Grout, HYDRO ACTIVE cut, HYDRO ACTIVE Flex LV, HYDRO ACTIVE Multi-gel NF, or HYDRO ACTIVE Safeoam, manufactured by De Neef Construction Chemicals, Houston, TX

Regardless of the method (or combination of methods) which are used, the Contractor shall demonstrate that permanent elimination of all infiltration has been achieved prior to the application of additional repair, rehab or protective coatings.

- 2) Repair materials shall be used to fill voids, structurally reinforce and/or rebuild surfaces, etc. as determined necessary by the engineer and protective coating applicator. Repair materials must be compatible with the specified epoxy coating and shall be applied in accordance with the manufacturer's recommendations. The following products may be accepted and approved as compatible repair basecoat materials for epoxy topcoating for use within the specifications:
 - a. 100% solids epoxy grout specifically formulated for epoxy topcoating compatibility. The epoxy grout manufacturer shall provide instructions for trowel or spray application and for epoxy topcoating procedures.
 - b. Factory blended, rapid setting, high early strength, non-shrink repair mortar that can be trowelled or pneumatically spray applied may be approved if specifically formulated to be suitable for epoxy, urethane or polyurethane topcoating. Such repair mortars should not be used unless their manufacturer provides information as to its suitability for topcoating with an epoxy, urethane or polyurethane coating. Project specific submittals should be provided including application, cure time and surface preparation procedures which permit optimum bond strength with the epoxy, urethane or polyurethane coating.
 - c. A premixed nonshrink cement-based patching material consisting of hydraulic cement, graded silica aggregates, special plasticizing and accelerating agents, which has been formulated for vertical or overhead use. It shall not contain chlorides, gypsums, plasters, iron particles, aluminum powder, or gas-forming agents or promote the corrosion of steel it may come into contact with. Set time (ASTM C-191) shall be less than 30 minutes. One hour compressive strength (ASTM C-109) shall be a minimum of 200 psi, and the ultimate compressive strengths (ASTM C-109) shall be a minimum of 5000psi. Bond strengths (ASTM C-882) Modified shall be a minimum of 1700 psi.

C. PROTECTIVE COATING MATERIALS

- 1) Definition: As used herein, the term "Protective Coating" shall refer to the final coat of material which is applied to the interior of the manhole. This material shall be designed to protect concrete manholes and other structures from attack by the components of domestic wastewater, particularly hydrogen sulfide gas

and the resulting sulfuric acid which is generated in sewer collection and transmission systems. In cases where other than domestic wastewater is being discharged (such as chemical plant effluents), in addition to any pre-treatment requirements, the District shall require that the Design Engineer submit in the design, a proposed method of protecting the sewer system from degradation by these constituents.

- 2) Protective Coating Manufacturers. The District recognizes that there are a variety of technologies which have been developed to protect concrete sewer structures; however, there can be no substitute for the skill and experience of the applicator. Subject to the training, certification, and experience of the applicator listed above, the following manufacturers are approved:
 - a. Raven Lining Systems, Inc., Tulsa, Oklahoma 800/324-2810 or 918/584-2810 or FAX 918/582-4311.
 - b. Mainstay Composite Liner, Reading, PA, 800/356-9023 or FAX 610/582-6064.
 - c. Permaform, Inc., Reading, PA, 800/356-9023 or FAX 610/582-6064.
 - d. Protective Liner Systems, Lithonia, GA, 770-482-5201, FAX 770-484-1821
 - e. Neopoxy International, Hayward, CA, (510) 782-1290 FAX (510) 782-1292
 - f. CCI Spectrum, Inc (Spectrashield), Jacksonville, FL (904) 268-4951, FAX (904) 268-4923
 - g. Sherwin-Williams Company, Protective & Marine Coatings Group, Jamestown, NC (336) 307-5048

Other products will be evaluated upon submittal; however, the decision of the District regarding equality shall be final.

C. STRUCTURAL RESTORATION

In certain instances, part of the rehabilitation requirements for a particular structure may be a partial restoration of the structural integrity of the manhole or vault. This is most-often observed in the case of brick manholes which have deteriorating mortar, or pre-cast manholes with advanced corrosion. In these cases, preferential selection shall be given to those rehabilitation technologies which are shown to provide an improvement in structural integrity, in addition to the protection from corrosion which

is common to all. District recognizes that each technology has unique characteristics which might make it the preferred method for a given structure. District reserves the right to select the technology which is most-advantageous to the District, given the overall asset management goals, and not necessarily the least-cost alternative in the short term.

15-05 PROTECTIVE COATING APPLICATION EQUIPMENT

- A. The Protective Coating Application Equipment shall be specifically designed, or approved for use by the protective coating manufacturer, for use in the application of the specified protective coating.
- B. Repair Mortar Spray Application Equipment shall be specifically designed, or approved for use by the manufacturer of the material for continuous mixing and spraying of the material.

15-06 EXECUTION

- A. ACCEPTABLE APPLICATORS
 - 1) Chemical grout applicators should be trained in the proper application and use of chemical grouts and all related equipment;
 - 2) Repair mortar applicators should be trained to properly apply the cementitious mortar according to manufacturer's recommendations.
 - 3) Protective coating must be applied by a Certified Applicator of the protective coating manufacturer and according to manufacturer specifications.
- B. EXAMINATION
 - 1) All structures to be coated shall be readily accessible to Applicator.
 - 2) Appropriate actions shall be taken to comply with local, state and federal regulatory and other applicable agencies with regard to environment, health and safety.
 - 3) Prior to the application of any concrete rehabilitative or protective coating, all infiltration must be permanently stopped by whatever means are necessary as described above. This may include the use of hydraulic cement, chemical injection grouts or other method.
 - 4) Any active wastewater flows shall be dammed, plugged or diverted as

required to ensure that the liquid flow is maintained below the surfaces to be coated. If required, flows will be totally plugged and/or diverted when coating the invert. All flows into the manhole or vaults at or above the area coated shall be plugged and/or diverted for the amount of time specified by the manufacturer or until the epoxy has set hard to the touch, whichever is less. As an option, hot air may be added to the manhole to accelerate set time of the coating.

- 5) The Contractor shall assume that structures which may be included in this project are part of the active District wastewater collection system. These structures must remain in operation continuously. However, flow may be stopped by the use of appropriately size inflatable or screw-operated plugs if this can be done intermittently or during periods of low flow. Also, the flow may be diverted through these structures by the installation of appropriate extension pipes or similar fixtures. It shall be the Contractor's responsibility to properly execute and schedule his work to permit the required rehabilitation and the proper application of the manhole coating to be achieved under the existing operating conditions of the District system. Any bypass pumping or other measures which may be required will be the responsibility of the Contractor at no additional compensation. Refer to SECTION 14 of this document for bypass pumping requirements.
- 6) Installation of the protective coating shall not commence until the concrete substrate has properly cured in accordance with the specifications of the protective coating and the substrate coating manufacturers.
- 7) Temperature of the surface to be coated should be maintained between 40 deg F and 120 deg F during application. Prior to and during application, care should be taken to avoid exposure of direct sunlight or other intense heat source to the structure being coated. Where varying surface temperatures do exist, care should be taken to apply the coating when the temperature is falling versus rising (ie. late afternoon into evening vs. morning into afternoon).

C. SURFACE PREPARATION

- 1) Applicator shall inspect all surfaces specified to receive a protective coating prior to surface preparation. Applicator shall notify Owner of any noticeable disparity in the surfaces which may interfere with the proper preparation or application of the repair mortar and protective coating.
- 2) All concrete or mortar that is not sound or has been damaged by chemical exposure shall be removed to a sound concrete surface.
- 3) All contaminants including: oils, grease, incompatible existing coatings, waxes, form release, curing compounds, efflorescence, sealers, salts, or other

contaminants shall be removed.

- 4) Surface preparation method(s) should be based upon the conditions of the substrate, service environment and the requirements of the protective coating to be applied.
- 5) All surfaces shall be repaired as required by the protective coating system in the intended service condition.
- 6) Surfaces to receive protective coating shall be cleaned and abraded to produce a sound surface with adequate profile and porosity to provide a strong bond between the protective coating and the substrate.
 - a. Generally, this can be achieved with a high pressure water cleaning using equipment capable of 5,000 psi at 4 gpm. Other methods such as high pressure water jetting (refer to NACE Standard No. 5/SSPC-SP12), abrasive blasting, shotblasting, grinding, scarifying or acid etching may also be used.
 - b. Detergent water cleaning and hot water blasting may be necessary to remove oils, grease or other hydrocarbon residues from the concrete. Whichever method(s) are used, they shall be performed in a manner that provides a uniform, sound clean neutralized surface that is not excessively damaged.
 - c. Debris resulting from surface preparation and cleaning shall be removed from the structure and not allowed to enter the wastewater flow.
 - d. Infiltration shall be stopped by using a material which is compatible with the specified repair mortar and is suitable for topcoating with the specified protective coating.
 - e. It is the contractors responsibility to test prepared surfaces after cleaning, but prior to application of the epoxy coating, to determine if a specific pH or moisture content of the concrete has been achieved if this is required according to manufacturer's recommendations.
 - f. The area between the manhole and the manhole ring and any other area that might exhibit movement or cracking due to expansion and contraction, shall be grouted with a flexible or elastomeric grout or gel. Coating of iron castings is not specifically required under this specification. However, District reserves the right to add this requirement if necessary. Additional compensation will be negotiated to cover abrasive blasting, or other surface preparation as needed.

D. APPLICATION OF REPAIR MATERIALS

- 1) Areas where structural steel, ladders, brackets or piping has been exposed (particularly wet well riser piping) shall be prepared in accordance with the manufacturer's instructions for the preparation of steel surfaces to receive the protective protective coating which will be applied to the concrete structure surfaces. All metal surface preparation, primer application, etc. required shall be performed at no additional compensation, except as provided in paragraph 14-06 C.6) f.
- 2) Certain steel structures which are no longer used (ladders, brackets, etc.), may, at the option of the Contractor and with the approval of the Owner, be removed and discarded provided any resulting holes are filled flush with the concrete surface using the rehab methods described above. The Contractor shall be responsible for disposal of all materials so removed and for the repair of any subsequent damage which may occur during or as a result of such removal. Any such work will be performed at no additional compensation.
- 3) Repair materials shall meet the specifications herein. The materials shall be trowel or spray applied utilizing proper equipment on to specified surfaces. The material thicknesses shall be as follows:
 - a. Concrete build-back material shall be of sufficient thickness to restore the structure to the original thickness, grade and contour.
 - b. Protective coating shall be applied to the thickness specified in the particular manufacturer's procedures.
 - c. If using approved cementitious repair materials, such shall be trowelled to provide a smooth surface with an average profile equivalent to coarse sandpaper to optimally receive the protective coating. No bugholes or honeycomb surfaces should remain after the final trowel procedure of the repair mortar.
 - d. The repair materials shall be permitted to cure according to manufacturer recommendations. Curing compounds should not be used unless approved for compatibility with the specified protective coating.
 - e. After abrasive blast and leak repair is performed, all surfaces shall be inspected for remaining laitance prior to protective coating application. Any evidence of remaining contamination or laitance shall be removed by additional abrasive blast, shotblast or other approved method. If repair materials are used, refer to these specifications for

surface preparation. Areas to be coated must also be prepared in accordance with these specifications after receiving a cementitious repair mortar and prior to application of the protective coating.

E. APPLICATION OF PROTECTIVE COATING

- 1) Application procedures shall conform to the recommendations of the protective coating manufacturer, including material handling, mixing, environmental controls during application, safety, and spray equipment.
- 2) The spray equipment shall be specifically designed to accurately ratio and apply the specified protective coating materials at the temperature specified by the manufacturer and shall be regularly maintained and in proper working order.
- 3) The protective coating material must be spray applied by a Certified Applicator of the protective coating manufacturer.
- 4) Airless spray application equipment approved by the coating manufacturer shall be used to apply each coat of the protective coating to avoid any potential contamination from compressed air oil which may encourage inter-coat delamination. Air assisted spray application equipment may be acceptable, especially for thinner coats (<10 mils), only if the air source is filtered to completely remove all oil and water.
- 5) If necessary, subsequent topcoating or additional coats of the protective coating should occur as soon as the basecoat becomes tack free, ideally within 12 hours but no later than 24 hours after the prior coat has been applied at unless additional prior coat surface preparation is performed. The protective coating manufacturer must be consulted for any additional-coat surface preparation guidelines if necessary.
- 6) Depending on wastewater flow levels and how long flow can be stopped, inverts may be lined with an approved 100% solids, fast setting epoxy coating, grout or cementitious material. This treatment is only approved for those surfaces which, after resumption of normal flows, will be constantly covered by a layer of flowing water. Every effort should be made to coat the entire invert with a continuous application of the approved protective coating.

15-07 TESTING AND INSPECTION

- A. During application, a wet film thickness gage, such as those available through Paul N. Gardner Company, Inc. meeting ASTM D4414 - Standard Practice for Measurement of Wet Film Thickness of Organic Coatings by Notched Gages, shall be used by the Applicator to ensure a monolithic coating and uniform thickness during application.

All results, will be verified by the Engineering Field Technician (EFT) in the field. Results shall be submitted to the EFT within 24 hours of testing.

- B. After the protective coating has set hard to the touch it shall be inspected with high-voltage holiday detection equipment. An induced holiday shall be made on to the coated concrete surface and shall serve to determine the minimum/maximum voltage to be used to test the coating for holidays at that particular area. The spark tester shall be initially set at 100 volts per 1 mil (25 microns) of film thickness applied but may be adjusted as necessary to detect the induced holiday. All detected holidays shall be marked and repaired by abrading the coating surface with grit disk paper or other hand tooling method. After abrading and cleaning, additional protective coating material can be hand applied to the repair area. All touch-up/repair procedures shall follow the protective coating manufacturer's recommendations.
- C. A final visual inspection shall be made by the Inspector and manufacturer's representative. Any deficiencies in the finished coating shall be marked and repaired according to the procedures set forth herein by Contractor.
- D. Final Vacuum Testing. After the structure has passed all testing listed above, the District may require that the structure be vacuum tested according to the procedures listed in SECTION 12-03 of this document.

SECTION 16

REHABILITATION OF SANITARY SEWER MAINS BY PIPE BURSTING

16-1 GENERAL

This specification covers the rehabilitation of existing sanitary sewers using a Pipe Bursting System or similar trenchless pipe replacement technology. Pipe bursting is a process by which the bursting unit splits and/or fractures the existing pipe while simultaneously installing a new pipe of the same or larger size into the annulus created by the forward movement of the bursting tool. Pipe Bursting is an alternative to the replacing of underground infrastructure by open cutting.

Pipe bursting work is divided into three classifications. These classifications are meant to be used as a general guideline when considering online replacement an existing pipe by pipe bursting.

Table 16:1 Pipe Bursting Project Design Classifications

Classification	Depth of Pipe	Existing Pipe Diameter	New Pipe Diameter Options	Burst Length
A – ROUTINE	< 12 ft	4 – 12 inch	Size for Size To 1 Up size 0	Up to 350 feet
B - CHALLENGING TO MODERATELY DIFFICULT	>12 ft < 18 ft	12 – 20 inch	2 Up sizes	350 – 450 ft
C - DIFFICULT TO EXTREMELY DIFFICULT	> 18 ft	20 – 36 inch	3 or more Up sizes	> 450 ft

16-2 SCOPE

- A. It is the intent of this specification to define the approved methods and materials for trenchless rehabilitation of existing sanitary sewer mains by the Pipe Bursting or similar trenchless pipe replacement methods. The work covered in this section includes the furnishing of all labor, materials, tools, equipment, and required incidentals and performing all operations in connection with the complete rehabilitation of the existing deteriorated sanitary sewer system piping.
- B. The District shall make available to qualified bidders, a copy of a video record of the pipe to be burst (“Preliminary CCTV”. Such videotape shall be warranted as an accurate reflection of the present condition of the pipe to be burst, at the time the video record was created. The Contractor shall utilize the video to determine the work effort needed to replace the existing pipe. Such work shall include the requirement for pipe bursting and any requirement for open-cut work necessary to

correct sags that currently exist within the existing pipe. As part of the preliminary work, the successful bidder shall be required to generate an up-dated CCTV record of the current condition of the pipe (“Confirmation CCTV”). Any major discrepancies between the Preliminary CCTV record and the Confirmation CCTV record shall be brought to the attention of the District and may be justification for an adjustment in scope.

C. The price per foot installed of the pipe specified shall include full compensation for furnishing all of the following:

- 1) Labor, materials, tools, equipment and back up equipment (necessary for pipe bursting), pipe;
- 2) Transportation, saw cutting, traffic control, excavation, shoring and backfilling per the manufacturers' instructions
- 3) Off-site disposal of all refuse and excess material; de-watering as necessary; bypass pumping of sewer mains and live service connection flows;
- 4) Service reconnections; replacement and modification of the manhole inverts and bottom channel to match newly installed pipe;
- 5) Pre and post CCTV inspections,
- 6) Temporary and permanent restoration of surfaces and pavement and all appurtenant work.
- 7) Compensation shall be at the actual length of pipe replaced. The length shall be measured from center of manhole to center of manhole.

16-3 REFERENCE STANDARDS

American Society for Testing Materials (ASTM), West Conshohocken, PA 14428

ASTM D 1238-99

ASTM D 1505 Standard Test Method for Density of Plastics by the Density-Gradient Technique

ASTM D790-00 Standard Test Methods for Flexural Properties of Unreinforced and Reinforced Plastics and Electrical Insulating Materials

ASTM D 638-99 Standard Test Method for Tensile Strength of Plastics

ASTM D1693 - 08 Standard Test Method for Environmental Stress-Cracking of Ethylene Plastic

ASTM D 3350 Standard Specification for Polyethylene Plastics Pipe and Fittings Materials

ASTM D 618	Standard Practice for Conditioning Plastics for Testing
ASTM D 2837	Standard Test Method for Obtaining Hydrostatic Design Basis for Thermoplastic Pipe Materials or Pressure Design Basis for Thermoplastic Pipe Products
ASTM D 575	Standard Test Methods for Rubber Properties in Compression

Refer also to the applicable standards for PVC pipe and DIP in gravity and pressure applications found in other sections of this document.

16-4 QUALIFICATIONS OF THE CONTRACTOR AND QUALITY ASSURANCE

- A. The Contractor shall be certified by the pipe bursting system manufacturer as a fully trained user of the pipe bursting or similar trenchless pipe replacement system. Operation of the pipe bursting system shall be performed by trained personnel. Such training shall be conducted by a qualified representative of the pipe bursting system manufacturer. The Contractor shall provide certificates of training for any employee directly involved in the supervision or operation of the pipe bursting system.
- B. Pipe jointing shall be performed by personnel trained as follows:
 - 1) For HDPE, personnel shall be trained in the use of butt-fusion equipment and the recommended methods for new pipe connections. Personnel directly involved with installing the new pipe shall receive training in the proper methods for handling and installing the polyethylene pipe. Such training shall be conducted by a qualified representative of the fusion equipment manufacturer.
 - 2) For DIP, personnel shall be trained in the proper makeup of restrained joints, installation of polyethylene wrapping, and any other tasks which are unique to the application of DIP to the pipe bursting process and which may be different from the procedures applicable to conventional open-cut installation of DIP.
 - 3) For PVC, personnel shall be trained in the proper makeup of restrained joints, and any other tasks which are unique to the application of restrained joint PVC to the pipe bursting process and which may be different from the procedures applicable to conventional open-cut installation of PVC pipe.
 - 4) Fusible PVC is not currently approved for installation in the District system. However, the Contractor may submit evidence of successful installations of this material for consideration.
- C. The Contractor shall hold the District harmless in any legal action resulting from patent infringements which may arise from the use of a given technology.

- D. Contractor experience: To qualify for bidding for any pipe bursting project the contractor shall have a minimum of 5,000 feet of pipe bursting experience within the past 12 months from project bid date and a minimum of 10,000 feet of cumulative pipe bursting experience. Specific projects and contact details with dates projects performed must be submitted and verifiable with all bid packages.
- E. Quality Assurance: the Contractor is solely responsible for quality assurance during the length of the project. The contractor shall be responsible for any costs associated with corrective measures required to replace or repair items not meeting the quality standards specified by the District.

16-5 SUBMITTALS

The Contractor shall submit the following items for review and approval by the District in accordance with the Contract Documents. Approval of the submittals by the District shall be obtained prior to ordering pipe materials and/or the start of the pipe replacement process.

- A. Certifications of training by the pipe bursting systems manufacturer as provided in paragraph 16-4 A. above.
- B. Certifications of training by the pipe fusion equipment manufacturers that the operators have been fully trained in the use of the fusion equipment by an authorized representative of the equipment manufacturer as provided in paragraph 16-4 B. above.
- C. Performance Work Statement (PWS): The Contractor shall submit, to the District, a Performance Work Statement (PWS) at the Pre-Construction Conference, which clearly defines the CIPP product delivery in conformance with the requirements of these contract documents. The PWS shall at a minimum contain the following:
 - 1) Project schedule.
 - 2) Detailed construction procedures, and layout plans to include sequence of construction.
 - 3) Locations, sizes and construction methods for the service reconnection pits.
 - 4) Methods of construction, reconnection and restoration of existing service laterals.
 - 5) The method of modification, if required, for existing manholes.
 - 6) Detailed procedures for the installation and bedding of pipe in the launching and receiving pits.

- 7) Sewer bypass plans, methods and list of equipment to be utilized. Refer to SECTION 14 of this document for bypass guidelines and requirements.
 - 8) A Safety Plan in conformance with the Contract Documents and OSHA regulations.
- D. Manufacturer's technical data showing complete information on material composition, physical properties and dimensions of the new pipe and fittings.
 - E. Manufacturer's recommendations for transport, handling, storage, and repair of pipe and fittings shall be included.
 - F. Traffic control plans.
 - G. Contingency plans for the following potential conditions:
 - 1) Unforeseen obstruction(s) causing burst stoppage, such as unanticipated change(s) in host pipe material, repair section(s), concrete encasement(s) or cradle(s), buried or abandoned manhole(s) or changes in direction not depicted on maps provided by the District.
 - 2) Substantial surface heave which occurs due to the depth of the existing pipe vs. the amount of upsizing
 - 3) Damage to existing service connections and to the replacement pipeline's structural integrity and methods of repair.
 - 4) Damage to other existing utilities.
 - 5) Loss of and return to line and grade.
 - 6) Soil heaving or settlement.

16-6 DELIVERY STORAGE AND HANDLING OF PIPE AND MATERIALS

- A. The Contractor shall transport, handle, and store pipe and fittings as recommended by manufacturer.
- B. New pipe and fittings that are damaged before or during installation it shall be repaired or replaced, as recommended by the manufacturer or required by the District. The costs of such repair or replacement shall be borne by the Contractor and be accomplished prior to proceeding with the project.

16-7 APPROVED METHODS OF PIPE BURSTING

- A. The most commonly used methods for pipe bursting are static and impact force. Static systems are hydraulic, while impact systems generally involve a combination of pneumatic and hydraulic technology. The main difference between methods is the manner in which the force is generated and transferred to the host pipe during the bursting operation.
- B. A variant of pipe bursting, generally applicable to VCP or PVC pipe only, involves a reaming process in which the host pipe is ground, by a reaming head, into shards which are compressed into the surrounding soil by the following tool. This specification shall be understood to apply to the reaming process as a variant of pipe bursting.
- C. The pipe bursting tool shall be pulled through the sewer by a winch or rod located at the upstream manhole. The bursting unit shall pull the polyethylene or DIP pipe with it as it moves forward. The bursting head shall incorporate a shield/expander to prevent collapse of the hole ahead of the new pipe insertion. The pipe bursting unit shall be remotely controlled. Replacement pipe that is sectional shall be pulled behind the bursting head.
- D. The bursting action of the tool shall increase the external dimensions sufficiently, causing breakage of the existing pipe at the same time expanding the surrounding ground sufficiently to pull in the new pipe.
- E. Approved suppliers of pipe bursting and similar pipe replacement technologies are as follows:
 - 1) Vermeer Hammerhead Mole Pipe Bursting System
 - 2) TT. Technologies Grundocrack® (Pneumatic)
 - 3) TT. Technologies Grundoburst® (Hydraulic/Static)
 - 4) Nowak Pipe Reaming, Inc. InneReam® system
 - 5) The District may consider the pipe bursting systems from other suppliers, provided they are shown to meet all requirements herein.

16-8 PIPE MATERIALS

The Contractor shall be required to submit manufacturer's data which substantiates that the particular pipe material, specific wall thickness, joint design, and other applicable characteristics render the material approved for use in pipe bursting projects and that the

proposed SDR is suitable for the depth and conditions (soil conditions and length) with an suitable safety factor.

- A. Polyethylene Plastic Pipe shall be high-density polyethylene pipe (HDPE) and meet the applicable requirements of ASTM F714 Polyethylene (PE) Plastic Pipe (SDR-PR) Based on Outside Diameter or AWWA C906, ASTM D1248 and ASTM D3350. The minimum wall thickness of the polyethylene pipe shall be as follows:
 - 1) Depth of Cover 0 - 16.0 feet minimum SDR-21
 - 2) Depth of Cover >16.0 feet minimum SDR-17
- B. Ductile Iron Pipe: Ductile Iron Pipe shall meet the requirements of AWWA C110
- C. Polyvinyl Chloride (PVC) Pipe: Polyvinyl Chloride Pipe shall be a restrained joining type such as Certa-Lok™ or Yelomine™ and conform to the requirements of ASTM D2241 and/or AWWA C900 or C905, with a DR11 rating.
- D. The Contractor shall install a new pipe sufficient in diameter to renew the sewer to the required flow capacity as specified by the District.

16-9 EXECUTION

- A. Locating Utilities. The District shall provide the Contractor with all documents relating too the location of utilities adjacent to the pipe to be replaced. The Contractor shall, prior to starting work, verify the location of all adjacent utilities. The minimum clearance from other utilities shall be approximately two feet.
- B. The Contractor shall expose all interfering and crossing utilities by spot excavating at the planar intersection of the pipe and removing the soil from around the utility. The cost of exposing these utilities shall be borne by the Contractor.
- C. The Contractor shall verify this information in the field. All additional subsurface investigations deemed necessary by the Contractor to complete the work shall be included in the Bid Proposal at no additional cost to the District. Copies of all reports and information obtained by the Contractor shall be provided to the District
- D. The minimum depth of cover over the installed pipe shall be ten times the amount of displacement from the diameter of the existing pipe or 3 feet (0.91m) from the top of the existing pipe, whichever is greater. The Contractor may, with the prior approval of the District, reduce the minimum depth of cover.
- E. A minimum amount of ground heaving may be allowed, as determined by the District, if soil conditions are not favorable and up-sizing of the pipe is required. Unless

otherwise noted in the Contract Documents, settlement or heaving of the ground surface during or after construction will not be allowed. The Contractor is solely responsible for the costs for repairing any surface heaving.

F. The Contractor shall locate all and expose all sewer service connections prior to pipe insertion to expedite reconnection. The Contractor shall exercise due diligence in excavating the existing pipe sufficiently to allow for uniform circumferential expansion of the existing pipe through the service connection pit. Upon commencement of the bursting process, pipe insertion shall be continuous and without interruption from one entry point to another. Upon completion of insertion of the new pipe, the Contractor shall expedite the reconnection of services to minimize any inconvenience to the customers.

G. Pipe Joining

1) HDPE

a. The polyethylene pipe (HDPE) shall be assembled and joined at the site using the butt-fusion method to provide a leak proof joint. All equipment and procedures shall be used in strict compliance with the manufacturer's recommendations. Fusion shall be performed by technicians certified by a manufacturer of pipe fusion equipment.

b. The Contractor shall cut out and replace defective fused joints in HDPE at no additional cost to the District. Any section of the pipe with a gash, blister, abrasion, nick, scar, or other deleterious fault greater in depth than ten percent (10%) of the wall thickness (ASTM 585), shall not be used and must be removed from the site. However, a defective area of the pipe may be cut out and the joint fused in accordance with the procedures stated above.

c. Terminal sections of pipe that are joined within the insertion pit shall be connected with a mechanical coupling (e.g. a full circle stainless repair clamp), Electro Fusion Couplings (e.g. Central Plastics or equivalent) or a non-shear restraint coupling. All connections shall be in conformance with the manufacturer's installation procedures.

2) DIP

a. Installation of restrained joints and polyethylene wrapping (if specified) shall be performed according to the pipe manufacturer's recommendations.

b. The dimensions of pipe entry pits shall be adequate to accommodate the manufacturer's maximum joint deflection angles, with a reasonable

margin of safety.

3) PVC:

- a. Installation of restrained joints shall be performed according to the pipe manufacturer's recommendations.
- b. The dimensions of pipe entry pits shall be adequate to accommodate the manufacturer's maximum joint deflection angles, with a reasonable margin of safety.

H. Bypassing Flows

The Contractor shall be responsible for continuity of sanitary sewer service to each facility connected to the section of sewer main during the execution of the work, and shall also bypass the main sewer flow around the pipe to be replaced, or into adjacent sanitary sewers, if available. Refer to SECTION 14 of this document for bypass guidelines and requirements.

I. Service Reconnection

- 1) The installed pipe shall be allowed to relax and cool according to the manufacturer's recommended amount of time, after which the Contractor shall reconnect all service connections.
- 2) Service connections shall be reconnected to the pipe by using connectors approved by the pipe manufacturer and in conformance with the specified installation procedure. Service connections shall be wrap around saddle (e.g. FERNCO or equivalent), Cast Iron w/ Gasket, T Connection (e. g. Inserta-T or equivalent or Electro Fusion (e.g. Central Plastics, Phillips Driscopipe, Plexco or equivalent). Connections to the existing service pipe shall be made using flexible couplings. All flexible couplings shall conform to ASTM C425. Joint deflection limits and lateral connections shall meet the maximums indicated in ASTM C12 and C425.
- 3) The slope of the existing lateral toward the newly installed sewer main shall be maintained at the existing percent. For reconstructed laterals, a minimum slope of one percent (1%) or as specified by the District.

J. Restoration

- 1) Restoration of Manholes
 - a. The Contractor shall restore all manholes and associated surface areas

to their original condition.

- b. If the new pipe is HDPE, prior to restoring manholes, the installed pipe shall be allowed the manufacturer's recommended amount of relaxation time, but not less than four (4) hours, prior to the sealing of the annulus or backfilling of the insertion pit. Sufficient excess length of new pipe, but not less than two (2) to four (4) inches, shall be allowed to protrude into the manhole to provide for shortening. Restraint of pipe ends shall be achieved by means of Central Plastics Electro Fusion coupling or equivalent. The electro- fusion couplings shall be slipped over pipe ends against manhole wall and fused in place. Installation of electro fusion couplings shall be done in accordance with the manufacturers recommended procedures.
- c. Restoration of the bottoms and inverts shall correspond to the requirements in Section 3 of this document.

2) Restoration of Pits

- a. The Contractor shall restore all lateral, launching pits and associated surface areas to their original condition as specified in Street Cut or Encroachment Permits.
- b. Prior to backfilling lateral and launching pits the Contractor shall ensure that the new pipe is properly supported and on the required grade. Refer to Construction Detail No. 11.

16-10 TESTING

A. CCTV Inspections

- 1) The Contractor shall perform post installation internal close-circuit television (CCTV) inspections of all installed pipe. Each reach of sewer shall have an audio description with appropriate stationing of services indicated. The data and stationing are to be on the video. All such inspections shall be performed by personnel trained in locating breaks, obstacles and service connections by CCTV. Refer to Section 12-5 of this Document
- 2) Post construction video DVDs are to be submitted to the for review along with any interim progress pay requests and prior to the final pay request. Should any portion of the inspection video be of inadequate quality or coverage, as determined by the District, the Contractor will have that portion of the CCTV work repeated at no additional expense to the District. All original video DVDs remain property of the District.

- B. The District reserves the right to require low pressure air testing as specified in SECTION 12-03 of this document. The Contractor shall be responsible for providing all test equipment including air compressor, plugs (both main line and service lateral), gauges, etc.
- C. In cases where the sewer main installed by pipe bursting has been connected to an existing manhole, the District will require that the manhole be vacuum tested.

16-11 WARRANTY

- A. The Contractor shall warrant the pipe bursting installation for a period of one (1) year. During the Contractor warranty period, any defect which may materially affect the integrity, strength, function and/or operation of the pipe, shall be repaired at the Contractor's expense.
- C. After a pipe section has been replaced by pipe bursting, and for a period of time up to one (1) year following completion of the project, the District may inspect all or portions of the new line. The specific locations will be selected at random by the District. If it is found that any of the pipe replaced by pipe bursting has developed abnormalities since the time of post-installation CCTV inspection, the abnormalities shall be repaired and/or replaced. As used in this document, the term "abnormalities" shall refer to any physical condition which negatively impacts the function of the sewer main or connected laterals, including groundwater infiltration, flat or reverse-grade condition, surface subsidence, out-of-roundness

SECTION 17

REHABILITATION OF SANITARY SEWER MAINS USING CURED-IN-PLACE PIPE

17-01 GENERAL

- A. These Specifications include the minimum requirements for the rehabilitation of sanitary sewer main pipelines by the installation of Cured-In-Place Pipe (CIPP) within the existing, deteriorated pipe.
- B. The rehabilitation of pipelines shall be done by the installation of a resin-impregnated flexible tube which, when cured, shall be continuous and tight-fitting throughout the entire length of the original pipe. The CIPP shall extend the full length of the original pipe and provide a structurally sound, jointless and water-tight new pipe within a pipe.
- C. The Contractor is responsible for proper, accurate and complete installation of the CIPP using the system selected by the Contractor.
- D. Neither the CIPP system, nor its installation, shall cause adverse effects to any of the Spartanburg Sanitary Sewer District (hereinafter referred to as the "District") processes or facilities. The use of the product shall not result in the formation or production of any detrimental compounds or by-products at the wastewater treatment plant.
- E. This specification is intended to primarily address the rehabilitation of sewer mains. Related rehabilitation needs, including problems at the service lateral connection to the main, and problems with the service lateral beyond the main, will be discussed as they relate to the primary subject of this section.

17-02 SCOPE

- A. These Specifications cover all work necessary to furnish and install, the Cured-In-Place-Pipe (CIPP). The Contractor shall provide all materials, labor, equipment, and services necessary for traffic control, bypass pumping and/or diversion of sewage flows, cleaning and television inspection of sewers to be lined, liner installation, reconnection of service connections, all quality controls, provide samples for performance of required material tests, final television inspection, testing of lined pipe system and warranty work, all as specified herein.
- B. The District shall locate and designate all manhole access points open and accessible for the work, and shall provide rights-of-access to these locations. If street must be closed to traffic because of the orientation of the sewer, the Contractor shall be

responsible for obtaining all encroachment or other permits from the governing agency.

- C. The District shall make available to qualified bidders, a copy of a video record of the pipe to be rehabilitated (“Preliminary CCTV”). Such videotape shall be warranted as an accurate reflection of the present condition of the pipe to be rehabilitated, at the time the video record was created. The Contractor shall utilize the video to determine the work effort needed to rehabilitate the existing pipe. Such work shall include the requirement for installation of CIPP and any requirement for open-cut work necessary to correct sags, protruding service connection, dropped joint, or a collapse that will prevent the CIPP installation process.
- D. As part of the preliminary work, the successful bidder shall obtain an up-dated CCTV record of the current condition of the pipe (“Confirmation CCTV”). Any major discrepancies between the Preliminary CCTV record and the Confirmation CCTV record shall be brought to the attention of the District and may be justification for an adjustment in scope. A videotape and suitable written log for each line section shall be produced and provided to the District as required below. Refer to Section 12-5 of this Document for the CCTV inspection requirements.
- E. Cleaning of Sewer Lines - The Contractor, shall remove all internal debris out of the sewer line that will interfere with the installation of CIPP, including roots and debris, and shall be responsible for proper disposal of all material removed. Unless stated otherwise, it is assumed that “proper disposal” will be the delivery of this material to the wastewater treatment plant designated by the District. Any hazardous waste material encountered during this project will be considered as a changed condition.
- F. By-passing Existing Sewage Flows - The Contractor shall provide for the flow of existing mainline and service connection effluent around the section or sections of pipe designated for CIPP installation. Service connection effluent may be temporarily plugged as provided below. The Contractor shall coordinate sewer bypass and flow interruptions with the District at least 14 days in advance and with the property owners and businesses at least 3 business days in advance. Refer to SECTION 14 of this document for bypass pumping guidelines and requirements. Compensation for by-pass pumping and all associated plans and approvals shall be included in the bid proposal.
- G. Public Notification - The Contractor shall make every effort to maintain sewer service usage throughout the duration of the project. In the event that a service connection will be out of service, the longest period of “no service” shall be 8 hours. Otherwise, the bypass requirements given above shall apply. The District shall oversee a public notification program which shall, as a minimum, require that each home or business connected to the sanitary sewer be contacted and informed of the work to be conducted, and when the sewer will be off-line.

- H. The Contractor shall be responsible for confirming the locations of all branch service connections prior to installing the CIPP. If, after the successful installation of the CIPP and the reinstatement of the sewer service lateral connections, it is determined that a problem exists at the connection of the service lateral to the main, the District may direct the Contractor to repair this problem. If performed by the Contractor, the cost for correcting problems with service connections shall be compensated at the unit price bid for Repair of Defective Service Lateral Connections.
- I. To supply any water which is required for the project, the Contractor shall contact the Customer Service Department of Spartanburg Water. After payment of applicable fees, a hydrant meter can be installed in a location convenient to the project.
- J. The Contractor shall cleanup, restore existing surface conditions and structures, and repair any of the CIPP system determined to be defective. The Contractor shall conduct installation operations and schedule cleanup in a manner to cause the least possible obstruction and inconvenience to traffic, pedestrians, businesses, and property owners or tenants.

17-03 DESIGN CRITERIA

- A. The CIPP shall be designed for a life of 50 years or greater in accordance with ASTM F1216, Appendix X.1, for “fully deteriorated gravity pipe conditions”. The minimum installed cured liner thickness shall be as follows:
 - 1) 8” sewer: 6.0 mm (0’ to 17’ deep)
7.5 mm (17’ to 25’ deep)
 - 2) 10” sewer: 6.0 mm (0’ to 11’ deep)
7.5 mm (11’ to 18’ deep)
9.0 mm (18’ to 25’ deep)
 - 3) 12” sewer: 7.5 mm (0’ to 12’ deep)
9.0 mm (12’ to 18’ deep)
10.5 mm (18’ to 25’ deep)
 - 4) 15” sewer: 7.5 mm (0’ to 10’ deep)
9.0 mm (10’ to 18’ deep)
10.5 mm (14’ to 20’ deep)
 - 5) For sewer mains larger than 15” or deeper than the depths given above, the Contractor shall submit design calculations prepared by a Registered Professional Engineer for the proposed wall thickness.
 - 6) Hydraulic Capacity - Overall, the hydraulic cross-section shall be maintained

as large as possible. The CIPP shall have a minimum of the full flow capacity of the original pipe before rehabilitation. Calculated capacities may be derived using a commonly accepted roughness coefficient for the existing pipe material taking into consideration its age and condition.

B. REFERENCE STANDARDS:

ASTM F1216 Rehabilitation of Existing Pipelines and Conduits by the Inversion and Curing of a Resin-Impregnated Tube)

ASTM F1743 Rehabilitation of Existing Pipelines and Conduits by Pulled-in-Place Installation of Cured-in-Place Thermosetting Resin Pipe (CIPP)

ASTM D5813 Cured-in-Place Thermosetting Resin Sewer Pipe

ASTM D790 Test Methods for Flexural Properties of Un-reinforced and Reinforced Plastics and Electrical Insulating Materials,

ASTM D2990 Tensile, Compressive, and Flexural Creep and Creep-Rupture of Plastics

17-04 PRODUCTS

A. CURED-IN-PLACE-PIPE LINING

- 1) CIPP lining shall be one of the following products or approved equal. The products below shall adhere to all requirements specified herein and shall be modified as necessary to meet these requirements.
 - a. Invert-A-Pipe by Improved Technologies Grout
 - b. National Liner by National EnviroTech Group, LLC
 - c. Inliner by Inliner Technologies, Inc.
 - d. Insituform by Insituform Technologies, Inc.
 - e. Diamond Lining Systems by Daystar Composites, LLC
 - f. Premier-Pipe USA by J.W.M. Environmental, Inc.
- 2) The liner shall be composed of tubing material consisting of one or more layers of flexible non-woven polyester felt, with or without other additives such as fiberglass or other reinforcing additives. The felt tubing shall be impregnated with a thermosetting isothalic polyester resin and catalyst or vinyl ester and catalyst. The liner material and resin shall be completely compatible. The inside and/or outside layer of the tube shall be coated with an impermeable material compatible with the resin and fabric. The liner shall cure in the presence of water at the required temperature for the resin system. Steam-cure shall not be allowed.

- 3) Resin - The resin system shall be a corrosion resistant polyester or vinyl ester system including all required catalysts, initiators that when cured within the tube create a composite that satisfies the requirements of ASTM F1216, ASTM D5813 and ASTM F1743, the physical properties herein, and those which are to be utilized in the submitted and approved design of the CIPP for this project. The resin shall produce a CIPP that will comply with the structural and chemical resistance requirements of this specification.

B. RELATED PRODUCTS

There are a variety of products which may be used as part of the work performed at the ends of the CIPP where they penetrate manholes and where they are penetrated by service lines. These products may include cement mortar grouts, hydraulic cement, and other specialized chemical grouts for stopping infiltration. It is beyond the scope of this section to specify the particular product or material to be used in a particular application. However, only products which are specifically manufactured for use in sanitary sewer manholes are approved. Regardless of the material used, the Contractor shall be responsible for the repair of all failures during the warranty period, whether or not they are related to a product or workmanship issue.

17-05 SUBMITTALS

A. Contractors Qualifications:

- 1) The Contractor shall have a minimum of three (3) years of continuous experience installing CIPP liners in pipe of a similar size, length and configuration as contained in this project. A minimum of 150,000 linear feet of shop wet-out liner installation is required and minimum of 6 onsite wet-out installations are required as applicable to this contract.
- 2) The Contractor's personnel shall have the following experience with the process and installation method to be used on this project:
 - a. Project Manager – Shall have a minimum of 3 years managing CIPP projects for wastewater collection systems.
 - b. Superintendent - Shall have a minimum of 2 years managing CIPP projects for wastewater collection systems.
 - c. The lead personnel including the superintendent, the foreman and the lead crew personnel for the CCTV inspection, resin wet-out, the CIPP liner installation, liner curing and the robotic service reconnections must have a minimum of three (3) years of total experience with the

CIPP technology proposed for this project and must have demonstrated competency and experience to perform the scope of work contained in this project.

- 3) The name and experience of each lead individual performing work on this contract shall be submitted with the bid documents.
- B. Design: Engineering design calculations, in accordance with the Appendix of ASTM F-1216, for each length of liner to be installed including the thickness of each proposed CIPP. It will be acceptable for the Contractor to submit a design for the most severe line condition and apply that design to all of the line sections. These calculations shall be performed and certified by a qualified Professional Engineer. All calculations shall include data that conforms to the requirements of these specifications.
- C. Performance Work Statement (PWS): The Contractor shall submit, to the District, a Performance Work Statement (PWS) at the Pre-Construction Conference, which clearly defines the CIPP product delivery in conformance with the requirements of these contract documents. The PWS shall at a minimum contain the following:
- 1) Clearly indicate that the CIPP will conform to the project requirements as outlined in these specifications.
 - 2) Where the scope of work is specifically delineated in the contract documents, a detailed installation plan describing all preparation work, cleaning operations, pre-CCTV inspections, by-pass pumping, traffic control, installation procedure, method of curing, service reconnection, quality control, testing to be performed, final CCTV inspection, warranties furnished and all else necessary and appropriate for a complete CIPP liner installation. A detailed installation schedule shall be prepared, submitted and conform to the requirements of this contract.
 - 3) Contractor's description of the proposed CIPP lining technology, including a detailed plan for identifying all active service connections maintaining service during mainline installation to each home connected to the section of pipe being lined.
 - 4) A description of the CIPP materials to be furnished for the project. Materials shall be fully detailed in the submittals and conform to these specifications and/or shall conform to the pre-approved product submission.
 - 5) Proposed manufacturers technology data shall be submitted for all CIPP products and all associated technologies to be furnished. Submittals shall include information on the cured-in-place pipe intended for installation and all tools and equipment required for a complete installation. The PWS shall

identify which tools and equipment will be redundant on the job site in the event of equipment breakdown. All equipment, to be furnished for the project, including proposed back-up equipment, shall be clearly described.

- 6) The Contractor shall outline the mitigation procedure to be implemented in the event of key equipment failure during the installation process.
- 7) A detailed description of the Contractor's proposed procedures for removal of any existing blockages in the pipeline that may be encountered during the cleaning process.
- 8) CIPP REPAIR/REPLACEMENT: Occasionally, unforeseeable problems with installation will result in the need to repair or replace a defective CIPP.
 - a. The Contractor shall outline specific repair or replacement procedures for potential defects that may occur in the installed CIPP. Repair/replacement procedures shall be as recommended by the CIPP system manufacturer and shall be submitted as part of the PWS.
 - b. Defects in the installed CIPP that will not affect the operation and long term life of the product shall be identified and defined.
 - c. Repairable defects that may occur in the installed CIPP shall be specifically defined by the Contractor based on manufacturer's recommendations, including a detailed step-by-step repair procedure, resulting in a finished product meeting the requirements of the Contract.
 - d. Un-repairable defects that may occur to the CIPP shall be clearly defined by the Contractor based on the manufacturer's recommendations, including a recommended procedure for the removal and replacement of the CIPP.

D. PRODUCT SUBMITTALS

- 1) Fabric Tube – including the manufacturer and description of product components.
- 2) Flexible membrane (coating) material – including recommended repair (patching) procedure if applicable.
- 3) Raw Resin Data - including the manufacturer and description of product components.
- 4) Manufacturers' shipping, storage and handling recommendations for all

components of the CIPP System.

- 5) All MSDS sheets for all materials to be furnished for the project.
 - 6) Tube wet-out & cure method including:
 - a. A complete description of the proposed wet-out procedure for the proposed technology.
 - b. The Manufacturer's recommended cure method - for each diameter and thickness of CIPP liner to be installed. The PWS shall contain a detailed curing procedure detailing the curing medium and the method of application.
- E. SAFETY: The Contractor shall submit a proposed Safety Plan to the Owner, prior to beginning any work, identifying all competent persons. The plan shall include a description of a daily safety program for the job site and all emergency procedures to be implemented in the event of a safety incident. All work shall be conducted in accordance with the Contractor's submitted Safety Plan.
- 1) The Contractor shall conform to all work safety requirements of pertinent regulatory agencies, and shall secure the site for the working conditions in compliance with the same. The Contractor shall erect such signs and other devices as are necessary for the safety of the work site.
 - 2) The Contractor shall perform all of the Work in accordance with applicable OSHA standards. Emphasis shall be placed upon the requirements for entering confined spaces and with the equipment being utilized for pipe renewal.

17-06 EXECUTION

Prior to beginning any work, the Confirmation CCTV shall be submitted to and approved by the District, along with the PWS which will outline any preparatory work (reduction of protruding service connections, repair of offset joints, pipe bellies, etc) needed on a given section of sewer main.

- A. The Contractor shall perform and provide all necessary traffic control measures to complete the work and shall be required to obtain all applicable encroachment permits. Warning signs, barricades, and flagmen must be provided in accordance with the Manual on Uniform Traffic Control Devices, or other SCDOT, Spartanburg County, or the City of Spartanburg permitting requirements.
- B. The Contractor shall clean and televise each length of pipe to be lined as specified in Paragraph 16-02 E. above. Only personnel trained and certified in locating breaks,

obstacles and service connections by closed circuit television shall perform the inspection. The Pipeline Assessment Certification Program (PACP) administered by the National Association of Sewer Service Companies (NASSCO) or similar program shall be considered the minimum qualification for the CCTV technician. The Contractor shall provide the District a copy of the pre-cleaning and post-cleaning video and suitable log in digital format for review prior to installation of the CIPP.

D. Line Obstructions - It shall be the responsibility of the Contractor to clear the line of obstructions that will interfere with the installation and long-term performance of the CIPP.

- 1) If pre-installation inspection reveals an obstruction, misalignment, broken or collapsed section or sag that was not identified as part of the original scope of work (Preliminary CCTV) and will prohibit proper installation of the CIPP, the Contractor may be directed by the District to correct the problem(s) prior to lining by utilizing open cut repair methods. The Contractor shall be compensated for this work under a contingency pay item designated for open cut point repairs. Removal of any previously unknown obstructions shall be considered as a changed condition.
- 2) The cost of removal of obstructions that appeared on the Preliminary CCTV documentation and made available to the Contractor, prior to the bid opening, shall be compensated for on a unit price basis in accordance with the contract documents.

E. Service Connections: The Contractor shall be responsible for confirming the locations of all branch service connections prior to installing and curing the CIPP.

- 1) The Contract Documents may require that each service connection be dye tested to determine whether the connection is live or abandoned. Such dye testing may be performed by District personnel as part of the Preliminary CCTV work. If performed by the Contractor, the cost for dye testing of existing service connections shall be compensated at the unit price bid in the Proposal for Dye Testing of Existing Service Connections.
- 2) In the event the status of a service connection cannot be adequately defined, the District will make the final decision, prior to installation and curing of the liner, as to the status. Unless specifically directed otherwise by the District, all service connections should be assumed to be active and shall be reopened by the Contractor.

F. Prior to lining the main sewer, protruding service lateral connections shall be internally cut or ground down flush with the pipe wall with a robotic cutter specifically designed for this purpose, and all required point repairs shall be completed. The internal cutter shall be capable of cutting cast iron, PVC, VCP,

DIP, and Orangeburg Pipe.

- G. The Contractor shall bypass pump sewer flows around the lining work while it is being performed. Refer to SECTION 14 of this document for bypass pumping guidelines and requirements.
- H. INSTALLATION OF LINER - The CIPP Liner shall be installed and cured in the host pipe per the manufacturer's specifications as described and submitted in the PWS. CIPP installation shall be in accordance with the applicable ASTM standards with the following modification:
- 1) The wet-out tube shall be positioned in the pipeline using the method specified by the manufacturer. Care should be exercised not to damage the tube as a result of installation.
 - 2) The tube should be pulled-in or inverted through an existing manhole or approved access point and fully extend to the next designated manhole or termination point
- I. Water shall be used to invert CIPP installed via ASTM F1216 or to invert the calibration hose through CIPP installed via ASTM F1743.
- 1) Air shall not be used to invert the CIPP or calibration hoses under any circumstances, unless combined with water being used with an installation vessel.
 - 2) The water inversion of the CIPP and calibration hoses shall be accomplished by using natural water pressure (head) achieved by erecting platforms or scaffolding to an elevation determined by the Contractor, or by using a CIPP installation vessel that creates water pressure.
 - 3) The Contractor shall determine the necessary inversion heads (pressure) for each line segment. If an installation vessel is used, a pressure relief valve shall be installed on the vessel so that the necessary pressure/inversion heads are not exceeded at any time during the inversions.
 - 4) The Contractor shall submit required inversion heads for each installation as a shop drawing without delay or claim to confidentiality or product/installation privacy.
 - 5) Prior to installation and as recommended by the manufacturer remote temperature gauges or sensors shall be placed inside the host pipe to monitor the temperatures during the cure cycle. Liner and/or host pipe interface temperature shall be monitored and logged during curing of the liner.

- 4) Curing shall be accomplished by utilizing the appropriate medium in accordance with the manufacturer's recommended cure schedule. The curing source or in and output temperatures shall be monitored and logged during the cure cycles. The manufacturer's recommended cure schedule shall be used for each line segment installed, and the liner wall thickness and the existing ground conditions with regard to temperature, moisture level, and thermal conductivity of soil, per ASTM as applicable, shall be taken into account by the Contractor.

J. COOL DOWN

- 1) The Contractor shall cool the CIPP in accordance with the approved CIPP manufacturer's recommendations as described and outlined in the PWS.
- 2) Temperatures and curing data shall be monitored and recorded by the Contractor throughout the installation process to ensure that each phase of the process is achieved as approved in accordance with the CIPP System manufacturer's recommendations.

K. FINISH

- 1) The installed CIPP shall be continuous over the entire length of a sewer line section and be free from visual defects such as foreign inclusions, dry spots, pinholes, major wrinkles and de-lamination. The lining shall be impervious and free of any leakage from the pipe to the surrounding ground or from the ground to inside the lined pipe.
- 2) Any defect, which will or could affect the structural integrity or strength of the linings, shall be repaired at the Contractor's expense, in accordance with the procedures submitted under Paragraph 16-05 C. 9) above.
- 3) The beginning and end of the CIPP shall be sealed to the existing host pipe. The sealing material shall be compatible with the pipe end and shall provide a watertight seal.
- 4) If, after the successful installation of the CIPP and the reinstatement of the sewer service lateral connections, it is determined that a problem exists at the connection of the service lateral to the main, the District may direct the Contractor to repair this problem. If performed by the Contractor, the cost for correcting problems with service connections shall be compensated at the unit price bid for Repair of Defective Service Lateral Connections.
- 5) If the wall of the CIPP leaks, it shall be repaired or removed and replaced with a watertight pipe as recommended by the manufacture of the CIPP system.

- 6) Compensation shall be at the actual length of cured-in-place pipe installed. The length shall be measured from center of manhole to center of manhole. The unit price per linear foot installed shall include all materials, labor, equipment and supplies necessary for the complete CIPP liner installation. Compensation for service connection sealing shall be at the unit price bid.

L. MANHOLE CONNECTIONS AND RECONNECTIONS OF EXISTING SERVICES

- 1) A seal, consisting of a resin mixture or hydrophilic seal compatible with the installed CIPP shall be applied at manhole walls in accordance with the CIPP System manufacturer's recommendations.
- 2) Reconnections of existing services shall be made after the CIPP has been installed, fully cured, and cooled down. It is the Contractor's responsibility to make sure that all active service connections are reconnected.
- 3) External reconnections are to be made with a tee fitting in accordance with CIPP System manufacturer's recommendations. Saddle connections shall be seated and sealed to the new CIPP using grout or resin compatible with the CIPP.
- 4) A CCTV camera and remote cutting tool shall be used for internal reconnections. The machined opening shall be at least 95 percent of the service connection opening and the bottom of both openings must match. The opening shall not be more than 100 percent of the service connection opening. The edges of the opening shall not have pipe fragments or liner fragments, which may obstruct flow or snag debris.
- 5) In the event that service reinstatements result in openings that are greater than 100 percent of the service connection opening, the Contractor shall install a CIPP type repair, sufficiently in size to completely cover the over-cut service connection. No additional compensation will be paid for the repair of over-cut service connections.
- 6) Coupons of pipe material resulting from service tap cutting shall be collected at the next manhole downstream of the pipe rehabilitation operation prior to leaving the site. Coupons may not be allowed to pass through the system.

17-07 FINAL INSPECTION AND REPORTS

- A. Following installation of the CIPP and reinstating all active service lateral connections, and completion of all manhole rehabilitation (including vacuum testing, see Section 12 of this Document), the Contractor shall conduct a final, Post-

Rehabilitation CCTV inspection of the completed work. No cleaning equipment shall be in the sewers during the Post-rehabilitation CCTV inspections. There shall be no water flowing in the pipe, so that the entire CIPP can be seen.

- B. Installation Reports shall be generated for each segment of liner installed, and shall be submitted along with the Post-Rehabilitation CCTV video. Refer to Section 12-5 of this Document for CCTV requirements.
- C. The Installation Report shall document the installation including manhole numbers, street names/sewer location, project number, date, time, temperature, curing temperature, curing time, liner thickness, etc. A sample report shall be submitted to the District for approval prior to installing any lining.

17-08 WARRANTY

- A. The materials used for the project shall be certified by the manufacturer for the specified purpose. The manufacturer shall warrant the liner and all supplied materials to be free from defects in raw materials for one (1) year from the date of installation and acceptance by the District.
- B. The Contractor shall warrant the liner installation for a period of one (1) year. During the Contractor warranty period, any defect which may materially affect the integrity, strength, function and/or operation of the pipe, shall be repaired at the Contractor's expense in accordance with procedures included in Paragraph 16-05 C. 9) above.
- C. After a pipe section has been lined and for a period of time up to one (1) year following completion of the project, the District may inspect all or portions of the lined system. The specific locations will be selected at random by the Owner and will include all sizes of CIPP from this project. If it is found that any of the CIPP has developed abnormalities since the time of " Post-Rehabilitation CCTV Inspection," the abnormalities shall be repaired and/or replaced as defined in Paragraph 16-05 C. 9). If, after inspection of a portion of the lined system under the contract, problems are found, the Owner may televise all the CIPP installed on the contract. All verified defects shall be repaired and/or replaced by the Contractor and shall be performed in accordance with Paragraph 16-05 C. 9) above and per the original specifications, all at no additional cost to the District.

SECTION 18

WARRANTY

18-01 GENERAL WARRANTY FOR ONE YEAR AFTER COMPLETION:

- 1) For a period of at least one year after the Spartanburg Sanitary Sewer District's final inspection, the Contractor shall warrant the fitness and soundness of all work done and materials and equipment put in place under the contract and neither the final certificate of payment nor any provision in the contract documents nor partial or entire occupancy of the premises by the Owner shall constitute an acceptance of work not done in accordance with the contract documents or relieve the Contractor of liability in respect to any express warranties of responsibility for faulty materials or workmanship. The Contractor shall remedy any defects in the work and pay for any damage to other work resulting therefrom, which shall appear within a period of one year from the date of final acceptance of the work unless a longer period is specified.
- 2) A second District inspection will be conducted 10 months after the date of acceptance of the project or the date of the SCDHE Final Construction Approval if applicable. The Owner or Contractor will be notified of observed defects after the "10-month" inspection is conducted. The Contractor will correct any defects prior to the expiration of the one-year warranty.
- 3) If in fulfilling the requirements of the contract or of any guarantee embraced therein or required thereby, the Contractor disturbs any work guaranteed under another contract, he shall restore such disturbed work to a condition satisfactory to the Engineer, and shall guarantee such restored work to the same extent as it was guaranteed under such other contract.
- 4) If the Contractor, after notice, fails to proceed promptly to comply with the terms of the guarantee, the Owner may have the defects corrected and the Contractor and his Surety shall be liable for all expenses incurred.
- 5) All special guarantees applicable to definite parts of the work that may be stipulated in the specifications or other papers forming a part of the Contract shall be subject to the terms of this paragraph during the first year of the life of such special guarantee.

18-02 MAINTENANCE

In addition to the guarantee stipulated in the Contract, each Contractor shall fully maintain all work performed under his contract for sixty (60) days after final completion and acceptance of the work. The retained percentage of contract payments shall not be due until after the 60 days maintenance period, except that the Owner may at his discretion release such retainer earlier.

APPENDIX A

STANDARD CONSTRUCTION DETAILS

CONSTRUCTION DETAIL NO. 1

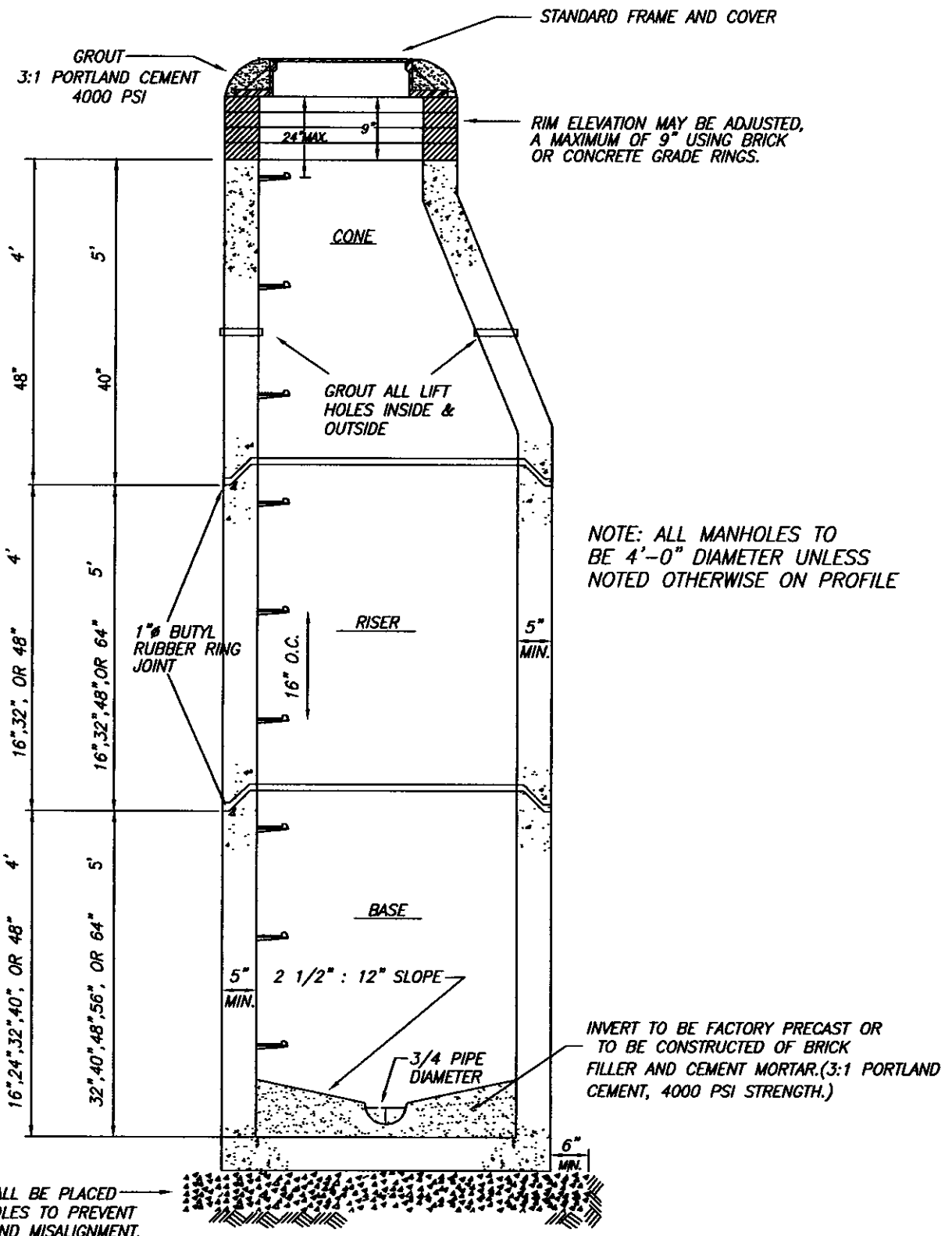

STANDARD PRECAST MANHOLE
N.T.S.

CONSTRUCTION DETAIL NO. 2

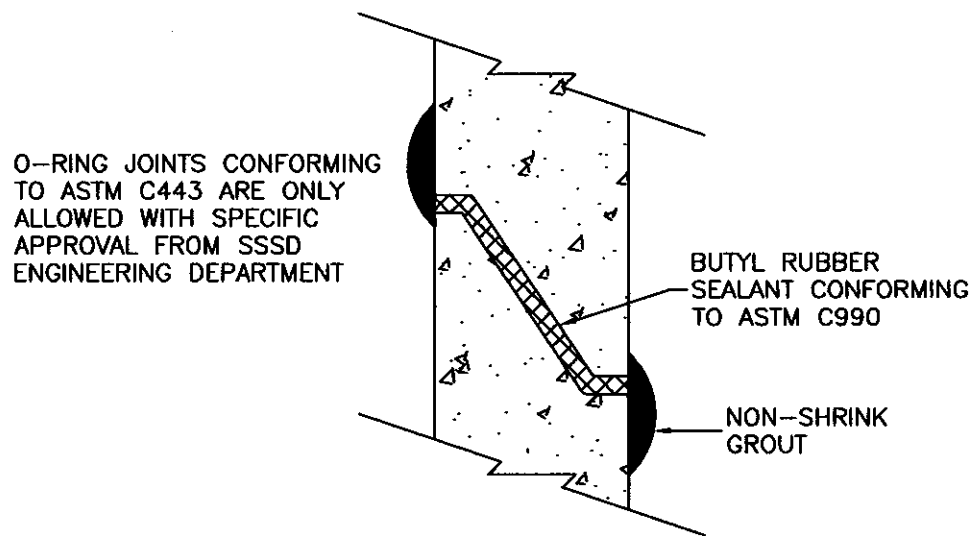

JOINT
DETAIL

STANDARD PRECAST MANHOLE JOINT DETAIL

CONSTRUCTION DETAIL NO. 3

SEWER LINES LESS THAN 12" – USE 4' ID MANHOLE
SEWER LINES 12" – 15" – USE 5' ID MANHOLE
SEWER LINES 15" – 24" – USE 6' ID MANHOLE
SEWER LINES GREATER THAN 24" – USE 8' ID MANHOLE

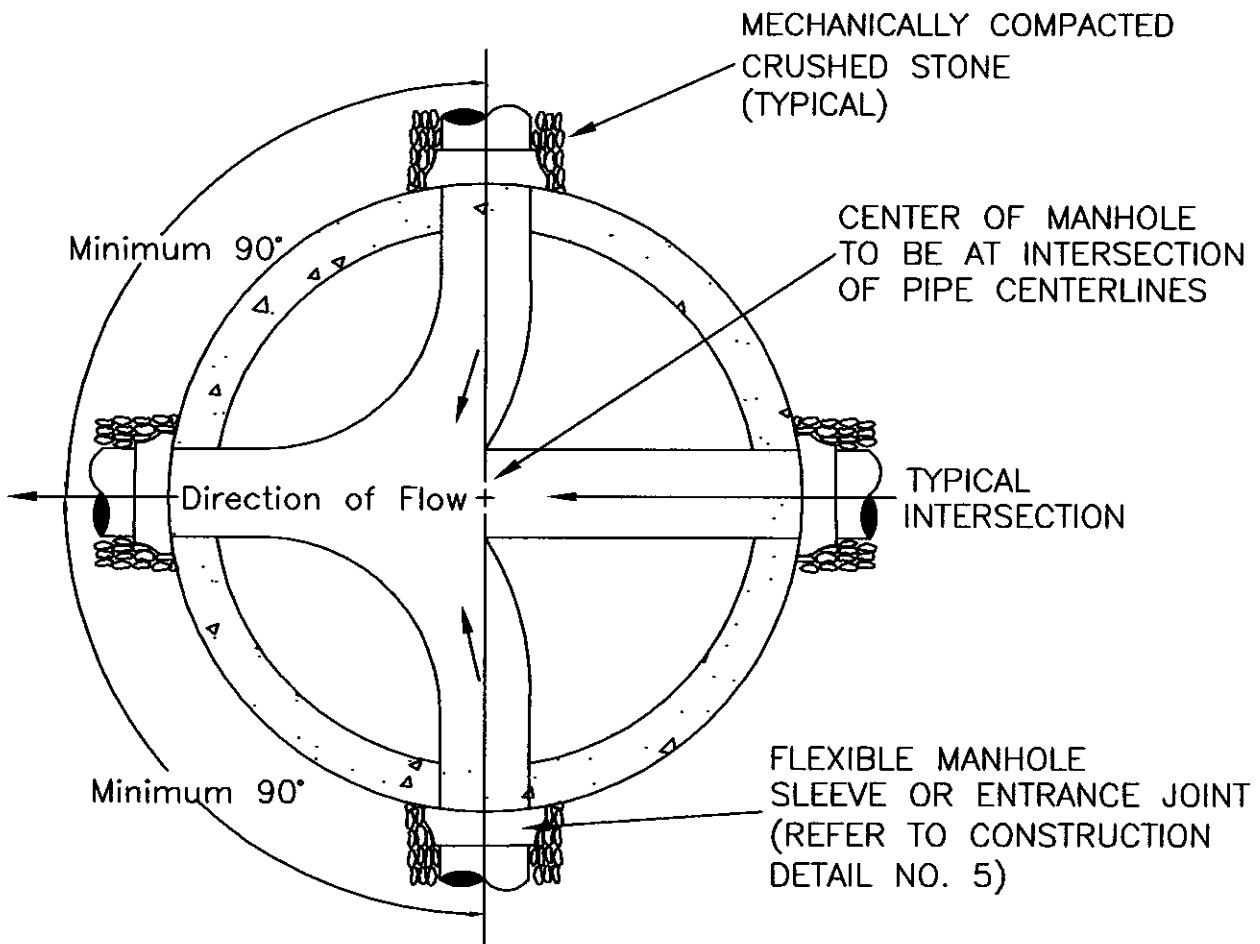

PLAN OF MANHOLE INVERTS
(Note: Shape All Inverts & Trowel Smooth)

CONSTRUCTION DETAIL NO. 4

STANDARD FRAME AND COVERS
EAST JORDAN IRON WORKS #V-1384
US FOUNDRY #USF-668, KL

WATERPROOF FRAME AND COVER
US FOUNDRY #USF-668, KL-BWTL
OR APPROVED EAST JORDAN IRON WORKS BOLT-DOWN

FLAT SLAB FRAME AND COVER
US FOUNDRY #USF-1261, KL
EAST JORDAN IRON WORKS #V-1384-4

COVER TO HAVE A SINGLE, 1" DIAMETER VENT HOLE, UNLESS BOLT-DOWN COVER IS SPECIFIED, IN WHICH CASE, THE GASKET SHALL PROVIDE POSITIVE SEAL AT BOLT HOLES.

FRAME AND COVER SHALL BE CERTIFIED FOR A MINIMUM OF AASHTO H-20 LOADING

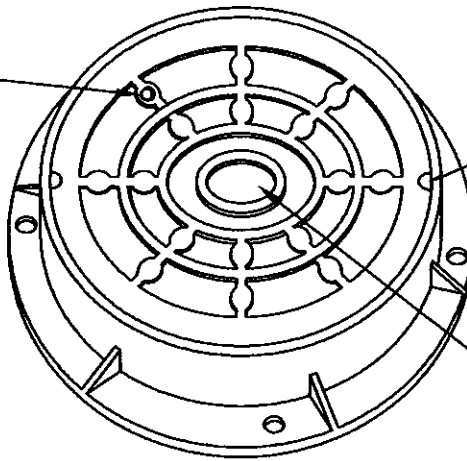

PROVIDE 2 (NON-PENETRATING) PICK HOLES

"S" OR "SANITARY SEWER" SHALL BE CAST ON THE COVER

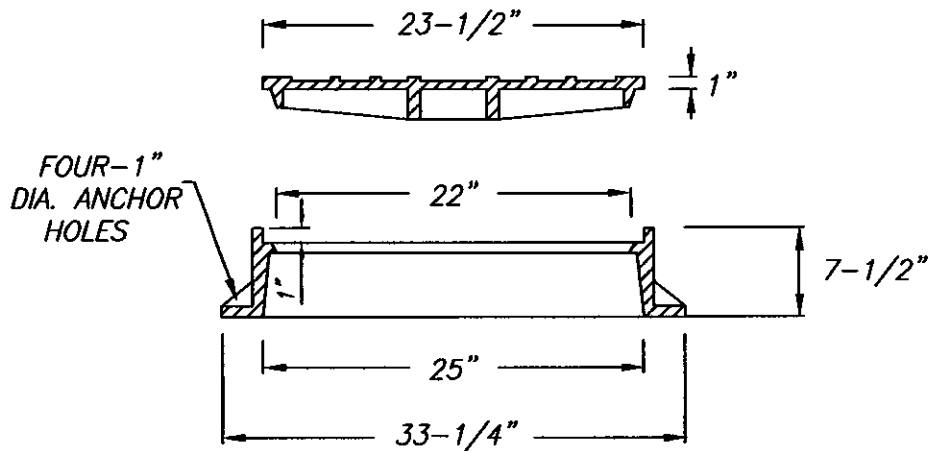

STANDARD MANHOLE
FRAME & COVER

N.T.S.

CONSTRUCTION DETAIL NO. 5

APPROVED MATERIALS

BOOTS - NPC (KOR-N-SEAL) AND PRESS-SEAL (PSX DIRECT DRIVE)

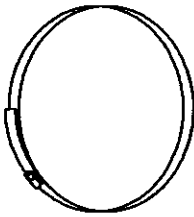

STAINLESS STEEL
PIPE CLAMP

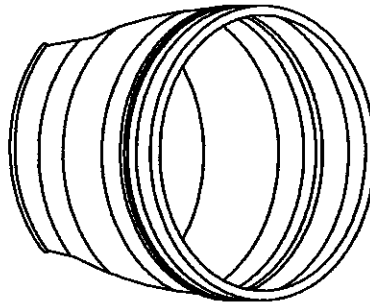

FLEXIBLE SYNTHETIC
RUBBER CONNECTOR

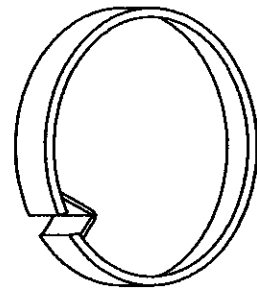

STAINLESS STEEL
EXPANSION RING

HOLE TO BE FACTORY-CORED
OR FIELD CORED AS NEEDED.
SIZE OF HOLE TO BE AS
RECOMMENDED BY THE BOOT
MANUFACTURER FOR THE SIZE
PIPE TO BE INSERTED.

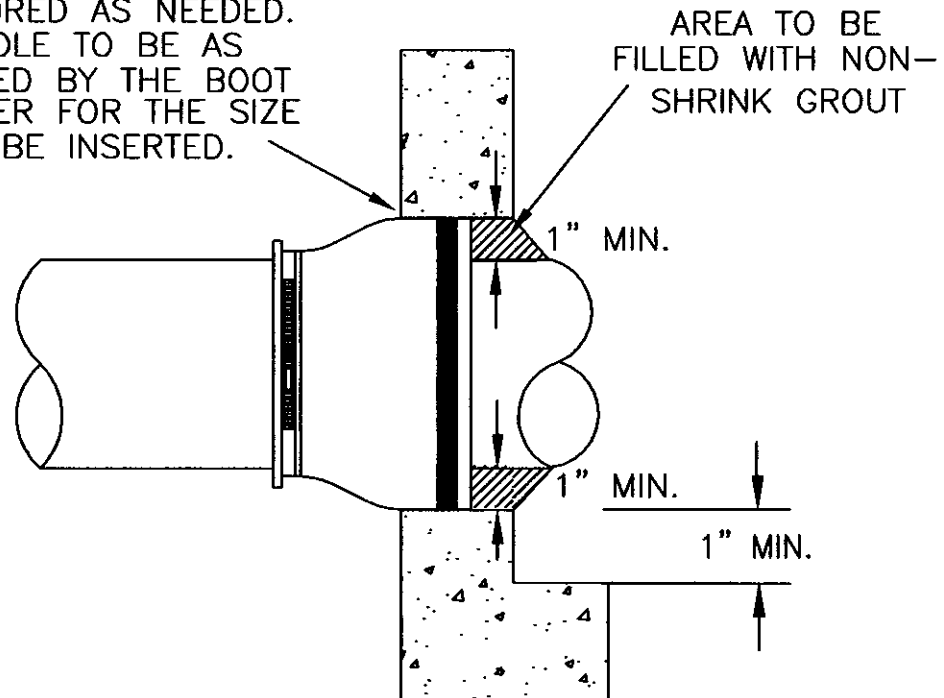

MANHOLE ENTRANCE "BOOT"

N.T.S.

CONSTRUCTION DETAIL NO. 6

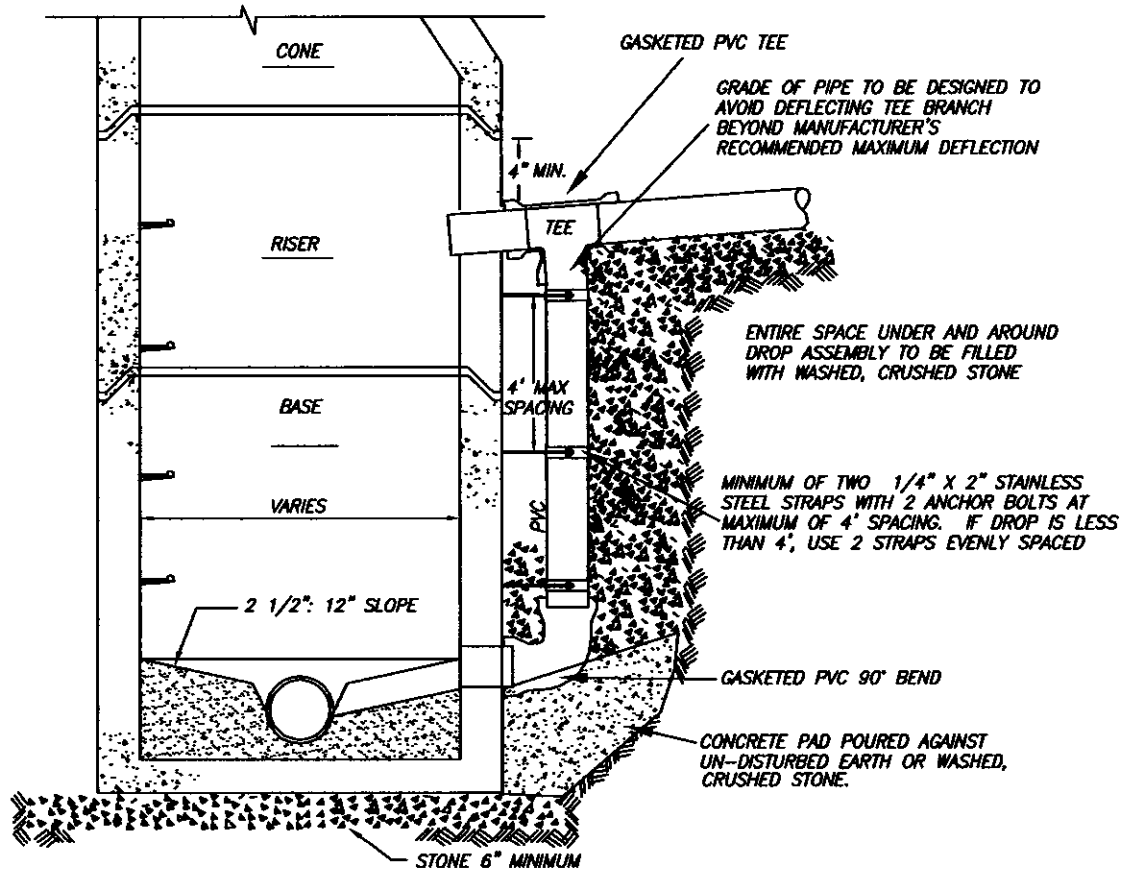

NOTES:

1. CARE MUST BE TAKEN TO FORM A SMOOTH FINISHED TROUGH FROM ENTRANCE PIPES TO EXIT PIPE, AND IN CURVED MANHOLES THE TROUGH MUST BE A SMOOTH CIRCULAR ARC TANGENT TO THE INSIDE WALLS OF THE PIPES AT THEIR ENDS.
2. THE SLOPE OF THE OUTSIDE DROP TROUGH SHALL BE 1/4" PER FOOT.
3. ALL PIPE OPENINGS TO BE NO GREATER THAN 3" LARGER THAN O.D. OF PIPE.
4. OUTSIDE DROP SHALL NOT ENTER MANHOLE IN CONE SECTION.
5. MATCH DROP INFLUENT CROWN TO CROWN WITH EFFLUENT PIPE
6. AT THE DISCRETION OF THE ENGINEERING FIELD TECHNICIAN (INSPECTOR) THE LOWER PIPE MAY ENTER THE MANHOLE SLIGHTLY ABOVE THE TABLE, AND A TROUGH CONSTRUCTED TO DIRECT THE FLOW INTO THE INVERT

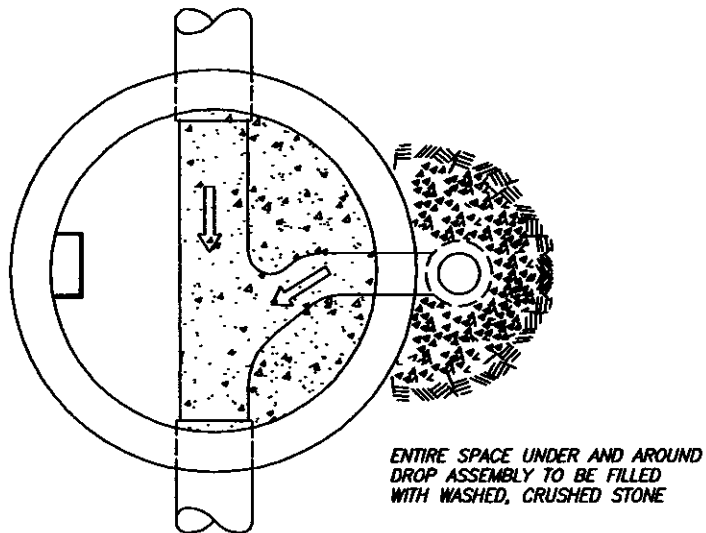

TYPICAL OUTSIDE DROP MANHOLE

N.T.S.

CONSTRUCTION DETAIL NO. 7

NOTES

- 1) INSIDE DROPS FOR MAIN LINES (8" AND LARGER) AND 6" SERVICE LINES ARE ONLY ALLOWED AS PART OF THE ORIGINAL SEWER DESIGN, WHEN THE DROP IS GREATER THAN 13.5' AND THE NEXT LARGER ID MANHOLE IS INSTALLED
- 2) INSIDE DROPS MAY BE INSTALLED FOR 4" AND 6" SERVICE LINES ON EXISTING MANHOLES WHEN THE DROP IS GREATER THAN 13.5' THE TEE AND DROP PIPE MUST BE SECURED AS CLOSE TO THE MANHOLE WALL AS POSSIBLE TO MINIMIZE RESTRICTION OF ACCESS.

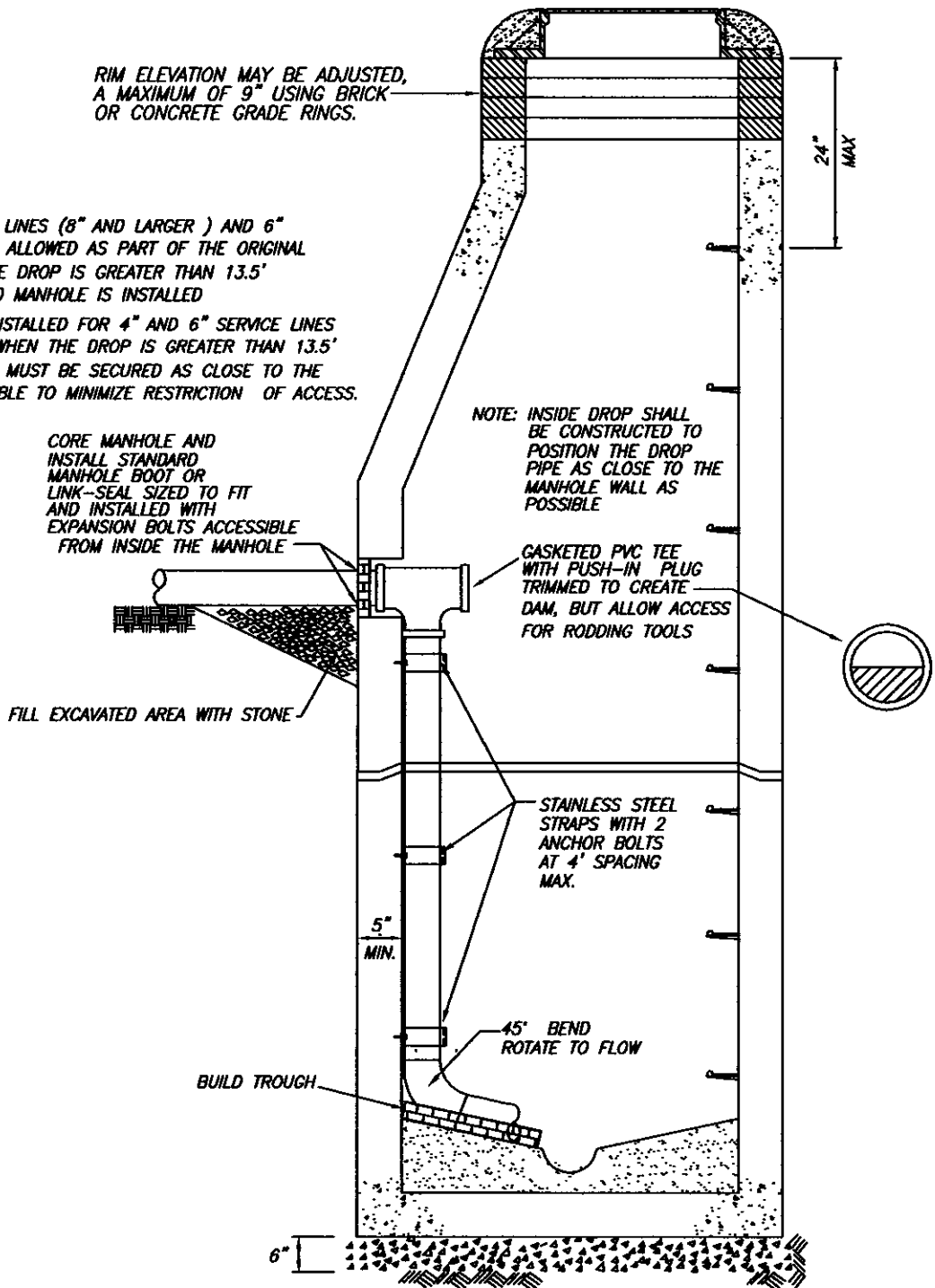

TYPICAL INSIDE DROP MANHOLE

N.T.S.

CONSTRUCTION DETAIL NO. 8

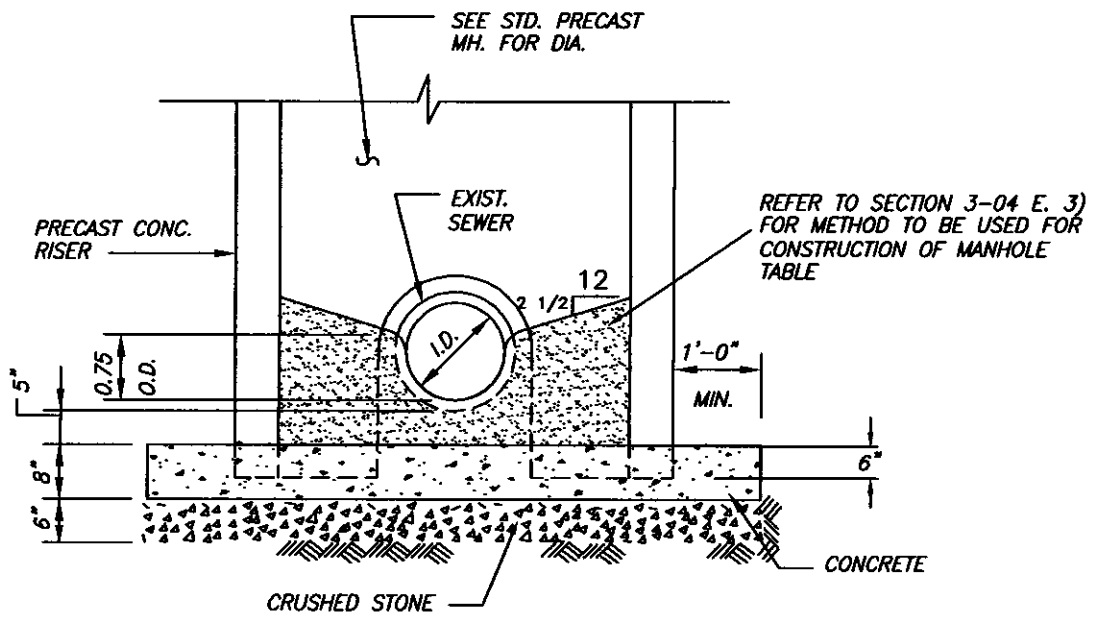

PRECAST MANHOLE (DOGHOUSE)
OVER EXISTING SEWER

N.T.S.

CONSTRUCTION DETAIL NO. 9

NOTES

- 1) DIMENSIONS OF CONCRETE COLLARS BASED ON 2000 P.S.F. SOIL BEARING.
- 2) SPECIFICATIONS OF MEGA-LUGS SHALL CONFORM TO THE PIPE MANUFACTURERS SUPPLIED SHOP DRAWINGS, WHICH SHALL INDICATE A THRUST RATING NOT LESS THAN THAT INCLUDED IN THE CHART BELOW.
THRUST COLLARS SHALL CONFORM TO THE PIPE MANUFACTURER'S SUPPLIED SHOP DRAWINGS WHICH SHALL INDICATE A THRUST RATING NOT LESS THAN THAT INCLUDED IN THE CHART BELOW.
- 3) DIMENSIONS OF WELDED STEEL OR DUCTILE IRON
- 4) CONCRETE SHALL HAVE A COMPRESSIVE STRENGTH OF 3,000 P.S.I. AT 28 DAYS. "HIGH EARLY" CONCRETE SHALL BE USED.
- 5) SOIL CONDITIONS SHALL BE VERIFIED BY THE S.W.S. INSPECTOR PRIOR TO CONSTRUCTION.
- 6) FOR 3" PIPE USE 4" DIAMETER THRUST RATING.

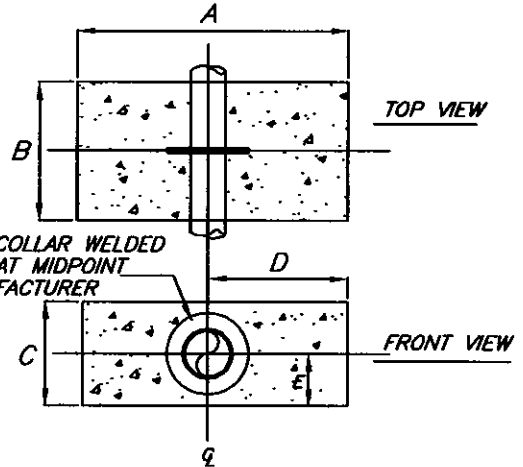

DETAIL "A" DIP ONLY

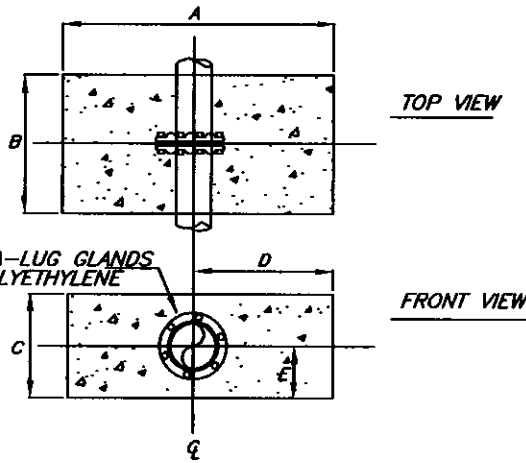

DETAIL "B" DIP ONLY

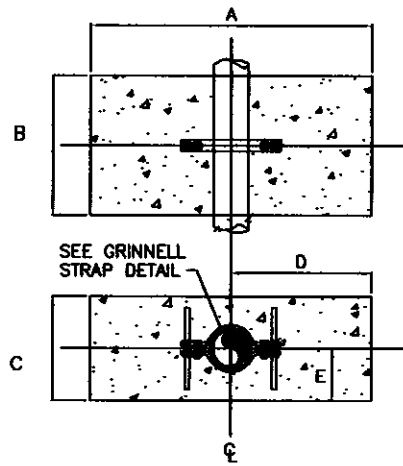

DETAIL "C" SDR-35 PVC or DIP

PIPE SIZE	A	B	C	D	E	CY.	WELDED THRUST COLLAR MINIMUM RATING
4"	3'-0"	2'-0"	1'-6"	1'-6"	0'-8"	0.33	4,500 lbs
6"	4'-0"	2'-0"	1'-6"	2'-0"	0'-9"	0.44	9,300 lbs
8"	4'-6"	2'-0"	2'-0"	2'-3"	1'-0"	0.67	16,000 lbs
12"	6'-0"	2'-0"	3'-0"	3'-0"	1'-6"	1.33	34,000 lbs
16"	6'-6"	2'-0"	4'-6"	3'-3"	2'-3"	2.17	59,000 lbs

TYPICAL CONCRETE COLLAR DETAIL

Detail "A" and "B" Apply to DIP in Gravity and Pressure Applications

Detail "C" Applies to SDR-35 PVC and DIP in Gravity Applications ONLY

CONSTRUCTION DETAIL NO. 10

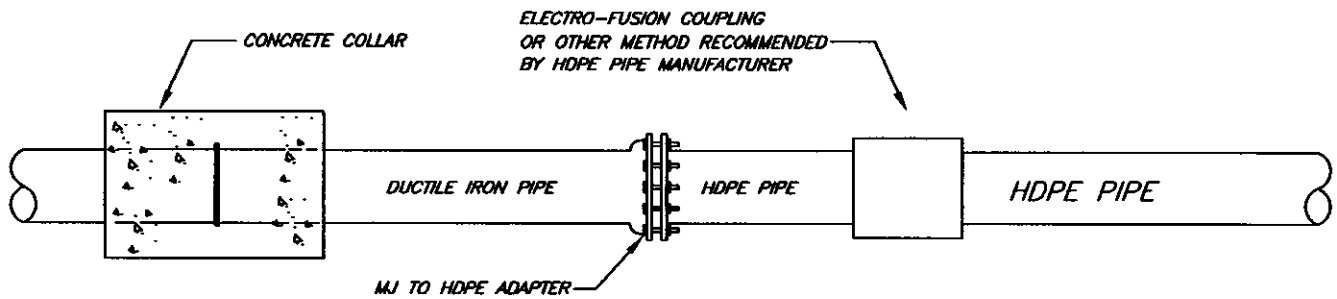

NOTE:

*INSTALLATIONS OF THE TYPE SHOWN ABOVE
MUST BE DESIGNED BY A LICENSED ENGINEER AND MUST
INCLUDE CONSIDERATION FOR THE FOLLOWING CONDITIONS:*

- SOIL TYPE*
- PIPE SIZE AND TYPE*
- EXCAVATION DEPTH*
- TEST PRESSURE*
- OPERATING PRESSURE*

*THE DESIGN MUST BE SUBMITTED TO THE SPARTANBURG
WATER ENGINEERING DEPT FOR APPROVAL.*

DIP TO HDPE TRANSITION

N.T.S.

CONSTRUCTION DETAIL NO. 11

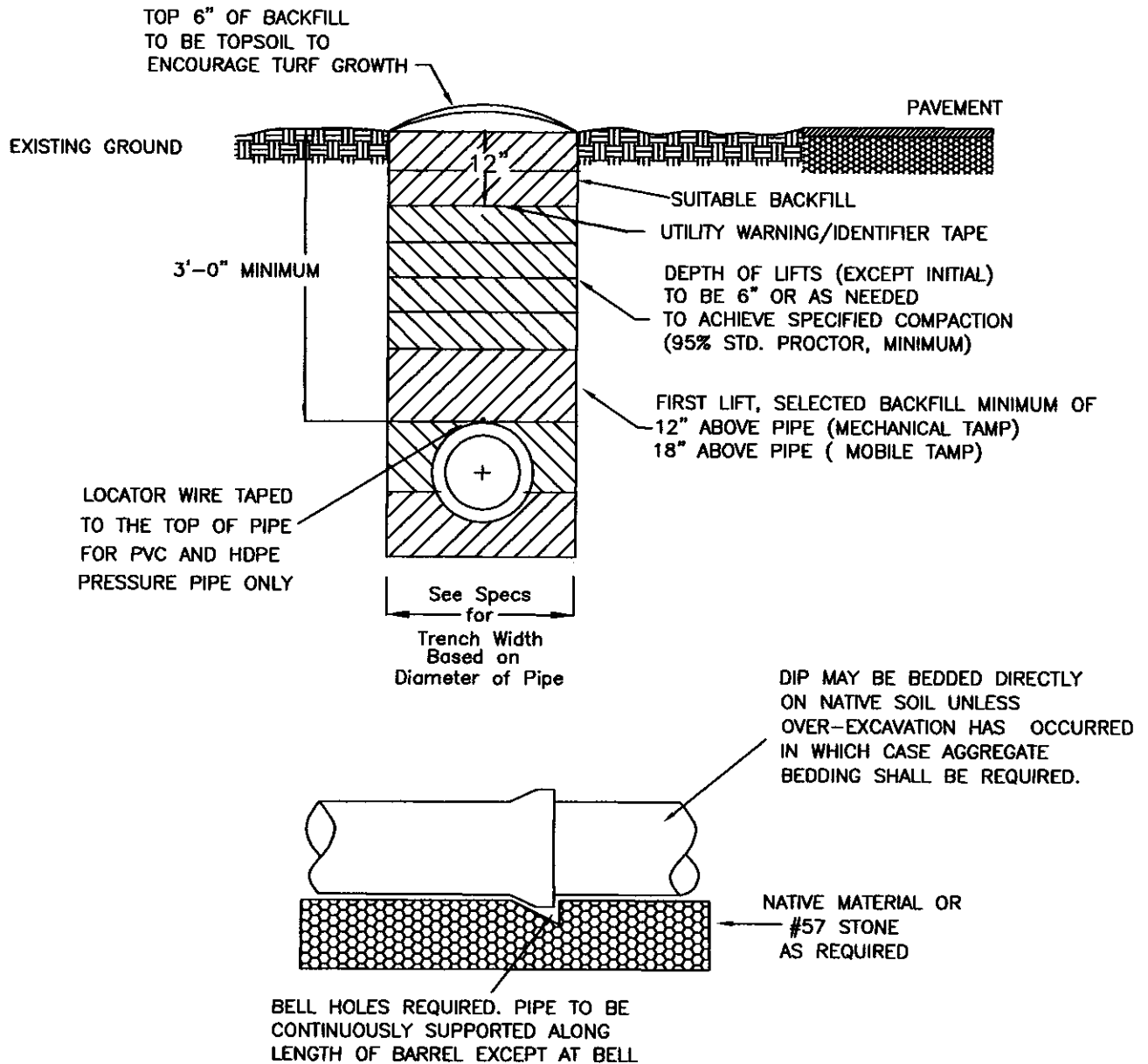

TYPICAL TRENCHING DETAIL

CONSTRUCTION DETAIL NO. 12

NOTES:

1. DITCH WIDTH NOT TO EXCEED B_d 2' OVER TOP OF THE PIPE.
2. PIPE SIZE 8" TO 30" DESIGN BASED ON (B_d MAX. DITCH WIDTH) NOT USING TRENCH BOX.
3. ALL (GRAVITY) PVC PIPE TO BE INSTALLED IN CLASS "B" DITCH BEDDING, UNLESS OTHERWISE NOTED.

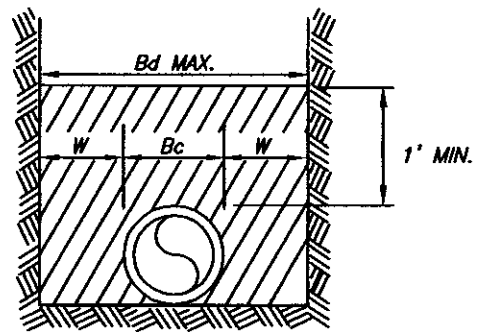
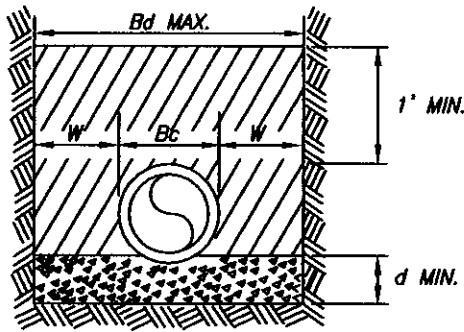
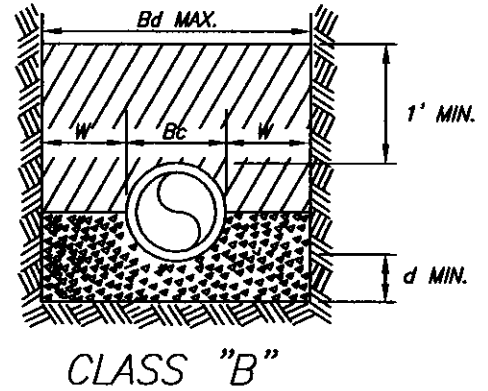

IMPROVED DITCH BEDDING DIMENSIONS FOR CLASS "B", "C" & "D"				
PIPE SIZE I.D.	B_c OUT DIA.	W MAX. WORK SPACE	B_d MAX. DITCH WIDTH	d DEPTH OF BEDDING UNDER PIPE
8"	10"	8"	2'3"	4"
10"	12"	9"	2'6"	4"
12"	14"	9"	2'9"	4"
15"	18"	10"	3'0"	4"
18"	22"	10"	3'6"	6"
21"	24"	9"	3'6"	6"
24"	27"	10"	4'0"	9"
27"	32"	10"	4'6"	9"
30"	36"	9"	4'6"	9"

IMPROVED DITCH BEDDING DETAIL

N.T.S.

CONSTRUCTION DETAIL NO. 13

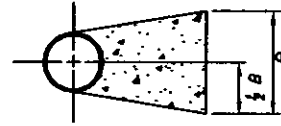
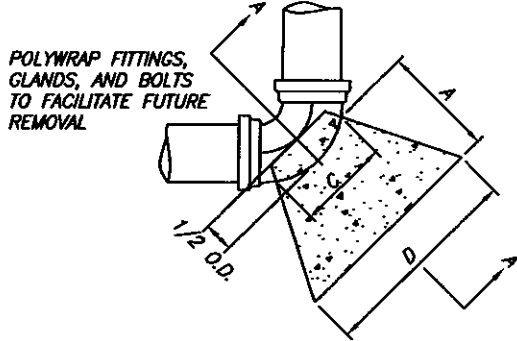

SECTION A-A

MINIMUM DIMENSIONS FOR CONCRETE BLOCKING

BEND	SIZE	VOLUME				CY
		A	B	C	D	
11 1/4°	6"	1'-0"	2'-0"	4"	1'-0"	0.05
	8"	1'-0"	2'-0"	5"	1'-0"	0.05
	12"	1'-0"	2'-0"	7"	1'-0"	0.05
	16"	1'-0"	2'-0"	1'-0"	2'-0"	0.22
	20"	2'-0"	3'-0"	1'-3"	2'-0"	0.32
22 1/2°	6"	1'-0"	2'-0"	6"	1'-0"	0.05
	8"	1'-0"	2'-0"	7"	1'-0"	0.05
	12"	1'-0"	2'-0"	10"	2'-0"	0.11
	16"	2'-0"	4'-0"	1'-0"	2'-0"	0.37
	20"	2'-0"	4'-0"	1'-3"	3'-0"	0.58
45°	6"	1'-0"	2'-0"	6"	1'-0"	0.05
	8"	1'-0"	2'-0"	7"	2'-0"	0.10
	12"	2'-0"	3'-0"	11"	3'-0"	0.44
	16"	3'-0"	5'-0"	1'-0"	3'-0"	1.00
	20"	4'-0"	6'-0"	1'-3"	4'-0"	2.15
90°	6"	1'-0"	2'-0"	1'-0"	2'-0"	0.11
	8"	2'-0"	3'-0"	1'-2"	2'-6"	0.37
	12"	2'-0"	4'-0"	2'-0"	4'-0"	0.84
	16"	4'-0"	6'-0"	2'-2"	4'-9"	2.84
	20"	4'-0"	7'-0"	2'-8"	6'-4"	4.51
TEES & PLUGS	6"	1'-0"	2'-0"	10"	1'-6"	0.08
	8"	1'-9"	2'-6"	1'-1"	2'-0"	0.23
	12"	2'-6"	3'-9"	1'-7"	3'-0"	0.75
	16"	3'-0"	5'-0"	2'-2"	4'-0"	1.59
	20"	4'-0"	6'-0"	2'-8"	5'-0"	3.21

FOR 3" & 4" PIPE, USE 6" SIZES

DESIGN DATA:

- DIMENSIONS OF THRUST BLOCK IN FEET BASED ON 2000 POUNDS PER SQUARE FOOT SOIL BEARING PRESSURE AND 200 POUNDS PER SQUARE INCH TEST PRESSURE. ACTUAL INSIDE DIAMETER OF DUCTILE IRON PIPE, CLASS 51 USED AS STANDARD.
- CONCRETE SHALL HAVE A COMPRESSIVE STRENGTH OF 3000 P.S.I. AT 28 DAYS. HIGH EARLY CONCRETE SHALL BE USED.

NOTE

SOIL CONDITIONS SHALL BE VERIFIED BY THE S.S.S.D. INSPECTOR BEFORE DESIGN IS IMPLEMENTED.

CONCRETE THRUST BLOCK DETAIL

N.T.S.

CONSTRUCTION DETAIL NO. 14

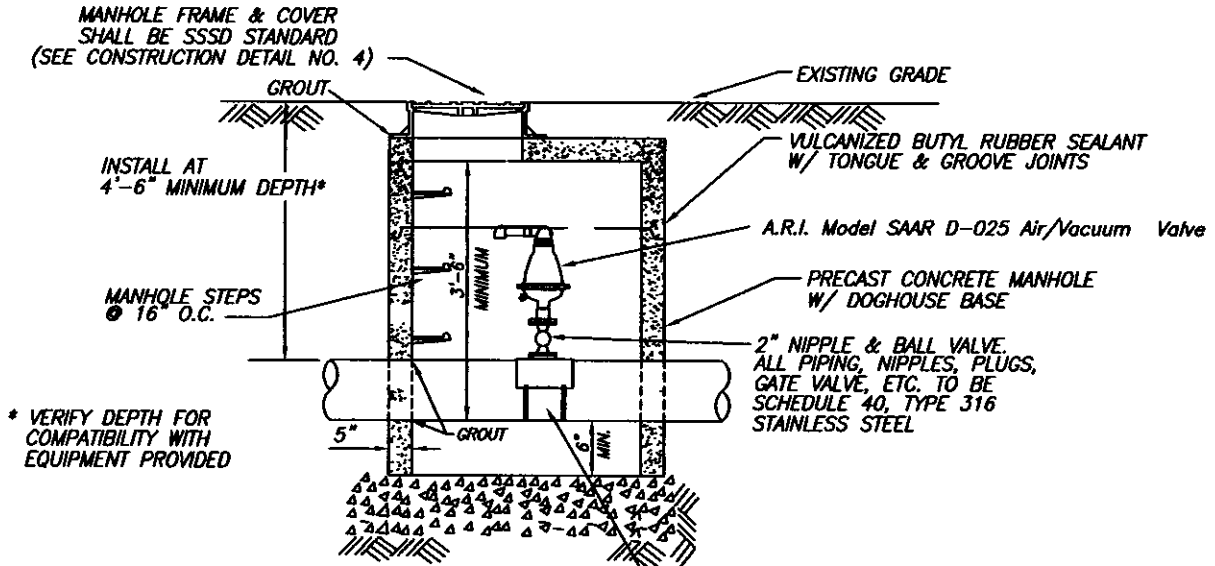

* VERIFY DEPTH FOR COMPATIBILITY WITH EQUIPMENT PROVIDED

DUCTILE IRON SERVICE SADDLE TAPPED 2" NPT W/ DOUBLE STAINLESS STEEL STRAP-CARRIER PIPE DRILLED 2". USE PVC SERVICE SADDLE WHEN TAPPING PVC.

IN SOME CASES, THE DESIGN ENGINEER MAY SUBMIT AN ALTERNATE DESIGN WHICH INCORPORATES A REMOTE MOUNTED AIR/VACUUM VALVE WHICH IS CONNECTED TO THE FORCE MAIN BY AN APPROPRIATELY-SIZED PIPING ARRANGEMENT, COMPLETE WITH ISOLATION VALVES AND VAULT.

ANY ALTERNATE DESIGN SHALL COMPLY WITH ALL REQUIREMENTS OF SCDHEC R.61-67 AND SHALL BE SUBMITTED TO THE ENGINEERING DEPARTMENT FOR APPROVAL.

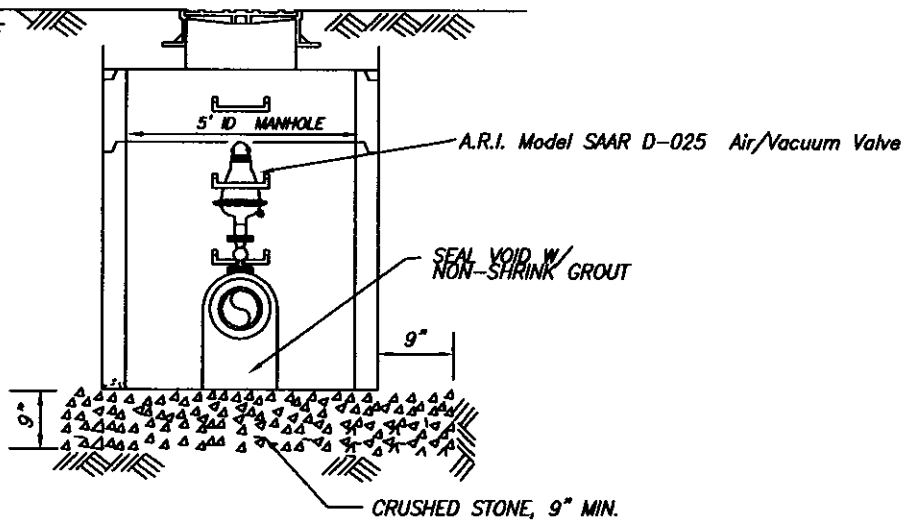

SEWER FORCE MAIN AIR/VACUUM VALVE AND MANHOLE

N.T.S.

CONSTRUCTION DETAIL NO. 15

NOTE:

ON NEW PIPE INSTALLATIONS, TRANSITION FROM PVC TO DIP AND DIP TO PVC SHALL BE MADE WITH GASKETED, PVC SLIP-JOINT COUPLINGS. FERNCO OR FLEXSEAL COUPLINGS ARE ONLY APPROVED FOR USE IN MAKING PIPING REPAIRS, NOT FOR TRANSITIONS IN NEW PIPE INSTALLATIONS.

NOTE:

ON NEW PIPE INSTALLATIONS, TRANSITION FROM PVC TO DIP AND DIP TO PVC SHALL BE MADE WITH GASKETED, PVC SLIP-JOINT COUPLINGS. FERNCO OR FLEXSEAL COUPLINGS ARE ONLY APPROVED FOR USE IN MAKING PIPING REPAIRS, NOT FOR TRANSITIONS IN NEW PIPE INSTALLATIONS.

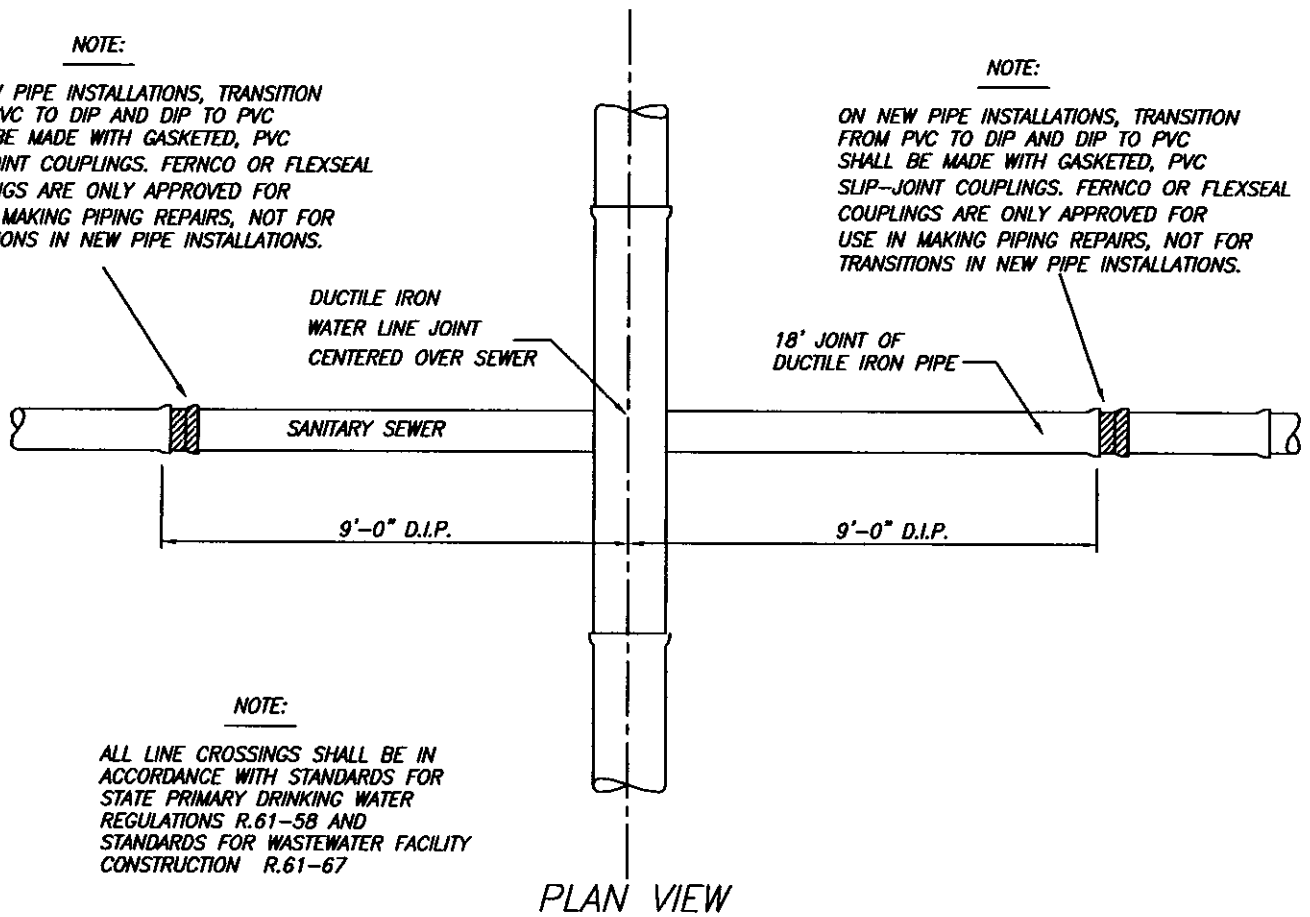

NOTE:

ALL LINE CROSSINGS SHALL BE IN ACCORDANCE WITH STANDARDS FOR STATE PRIMARY DRINKING WATER REGULATIONS R.61-58 AND STANDARDS FOR WASTEWATER FACILITY CONSTRUCTION R.61-67

PLAN VIEW

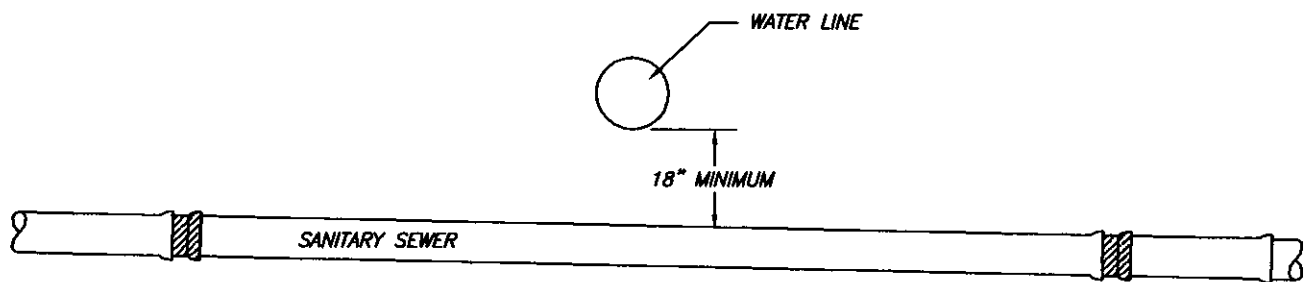

SECTION VIEW

SANITARY SEWER AND WATER LINE/ STORM DRAIN CROSSING DETAIL

N.T.S.

CONSTRUCTION DETAIL NO. 16

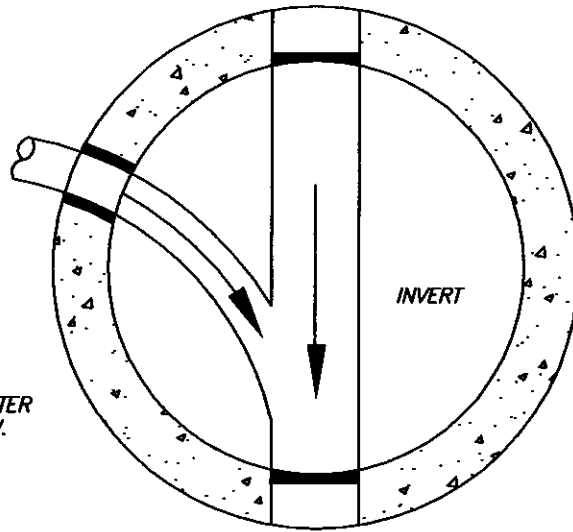

NOTE:

SERVICE LINE MUST ENTER
MANHOLE AT ANGLE NO GREATER
THAN 90° DIRECTION OF FLOW.

PLAN

CORE APPROPRIATE SIZE HOLE,
INSTALL STANDARD MANHOLE BOOT
AND FINISH PER REQUIREMENTS
FOR MAINLINE CONNECTIONS
(SEE CONSTRUCTION DETAIL NO. 5)

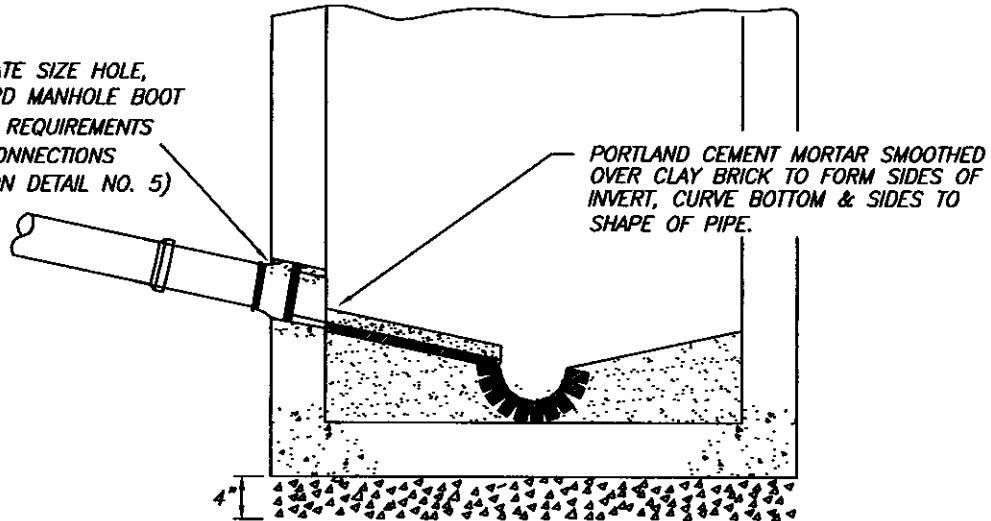

IF SLOPE OF TABLE IS LESS THAN 2 1/2" PER FT.,
THEN THE INVERT OF THE SERVICE LINE SHALL
ENTER MANHOLE 6" ABOVE TABLE AND A SERVICE
INVERT SHALL BE FORMED ON THE TABLE. OTHERWISE,
THE SERVICE SHALL ENTER AT TOP OF TABLE.

SECTION

SERVICE LINE TAP TO MANHOLE
(FOR SERVICE LINES 6" OR SMALLER)

N.T.S.

CONSTRUCTION DETAIL NO. 17

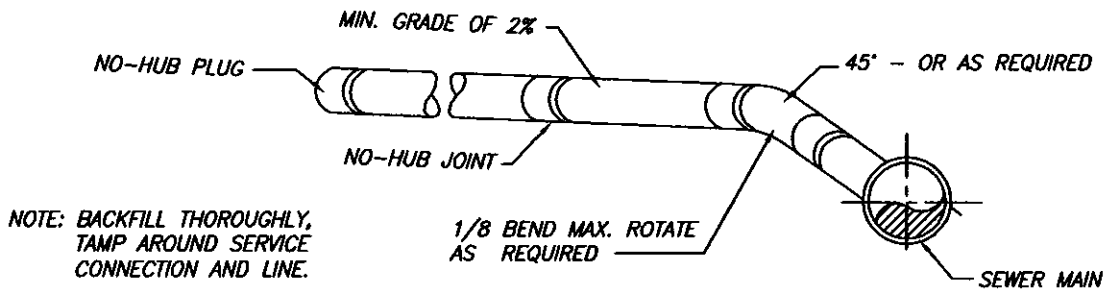
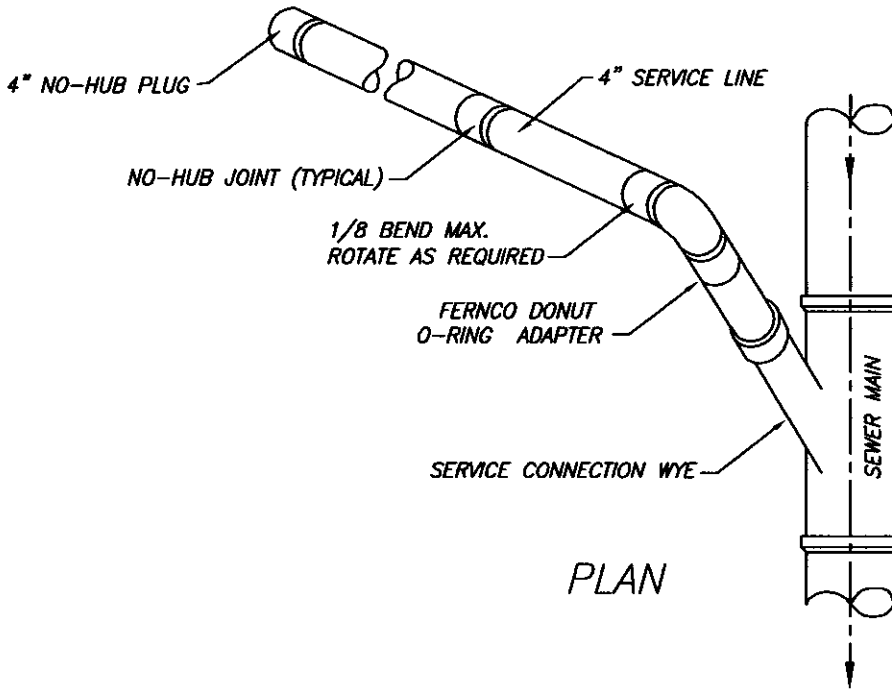

SECTION

TYPICAL SEWER SERVICE CONNECTION

N.T.S.

CONSTRUCTION DETAIL NO. 19

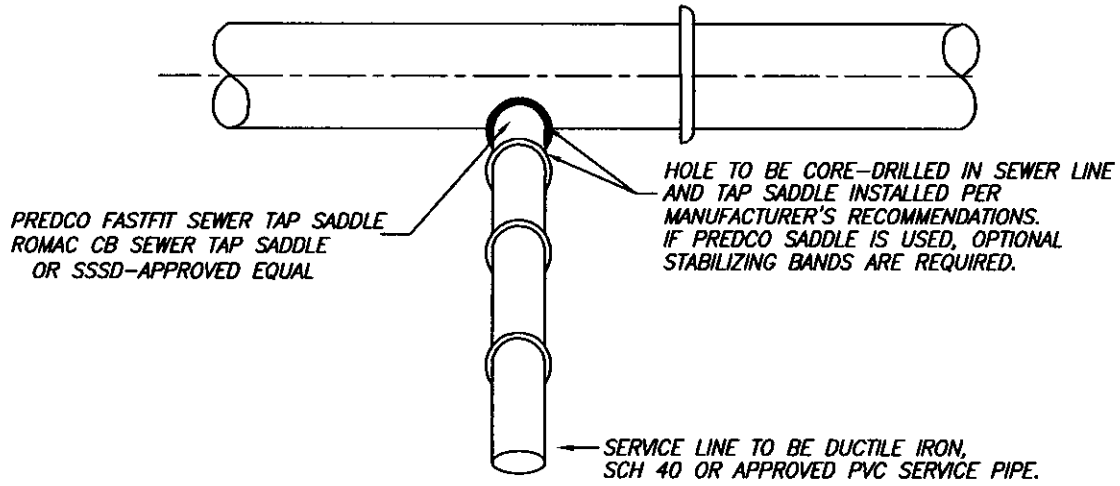

PLAN

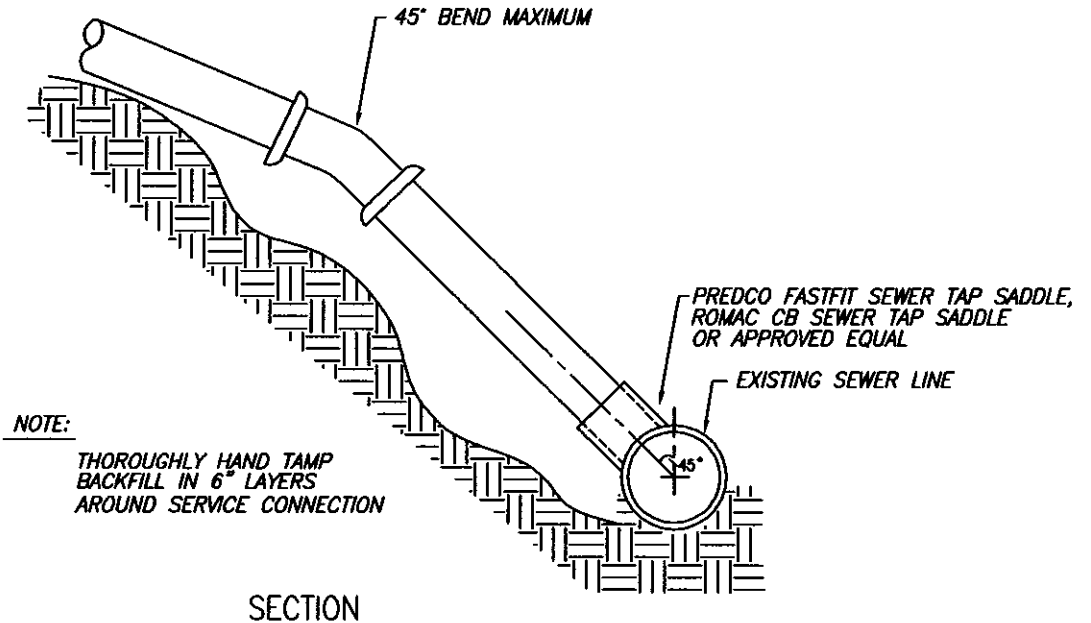

SECTION

SERVICE LINE TAP
TO EXISTING SEWER LINE

N.T.S.

CONSTRUCTION DETAIL NO. 20

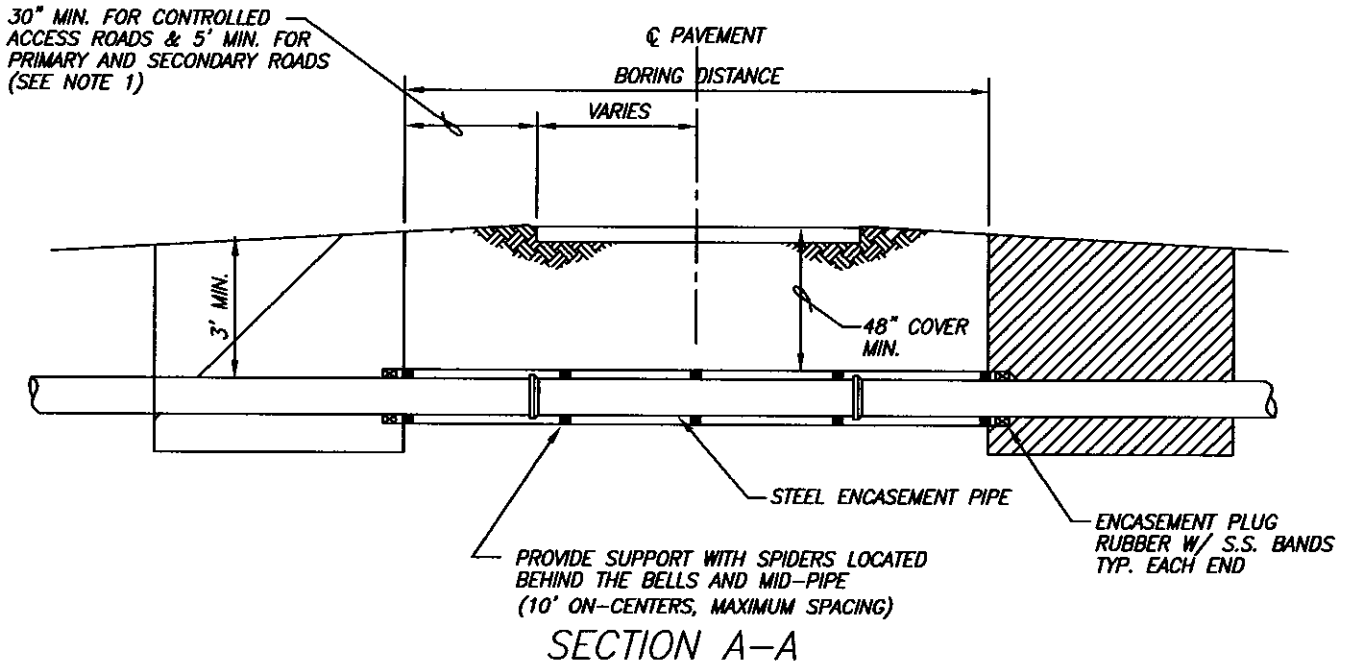
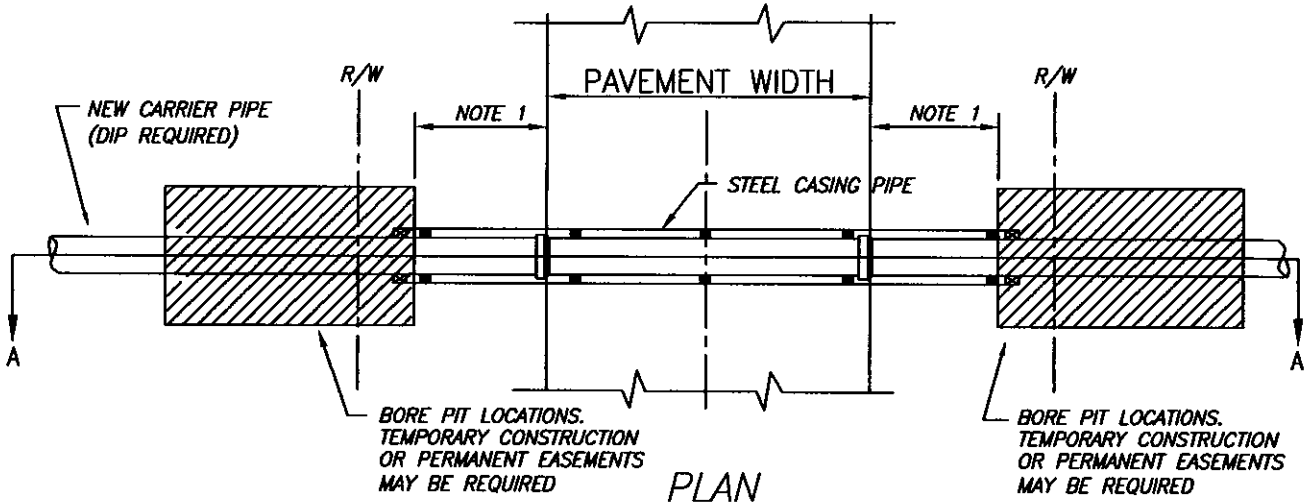

NOTES:

1. THE NEAR EDGE OF THE PIT CAN BE NO CLOSER TO THE EDGE OF THE TRAVELWAY THAN ITS DEPTH BELOW THE SURFACE OF THE TRAVELWAY UNLESS BULKHEADED.
2. ALL PIPE WITHIN AND TO 5' OUTSIDE THE CASING TO BE D.I.P.
3. ALL PIPING IN CASING SHALL UTILIZE LOCKING GASKETS SUPPLIED BY THE PIPE MANUFACTURER.

CASING PIPE BORE AND JACK DETAIL

NTS

CONSTRUCTION DETAIL NO. 21

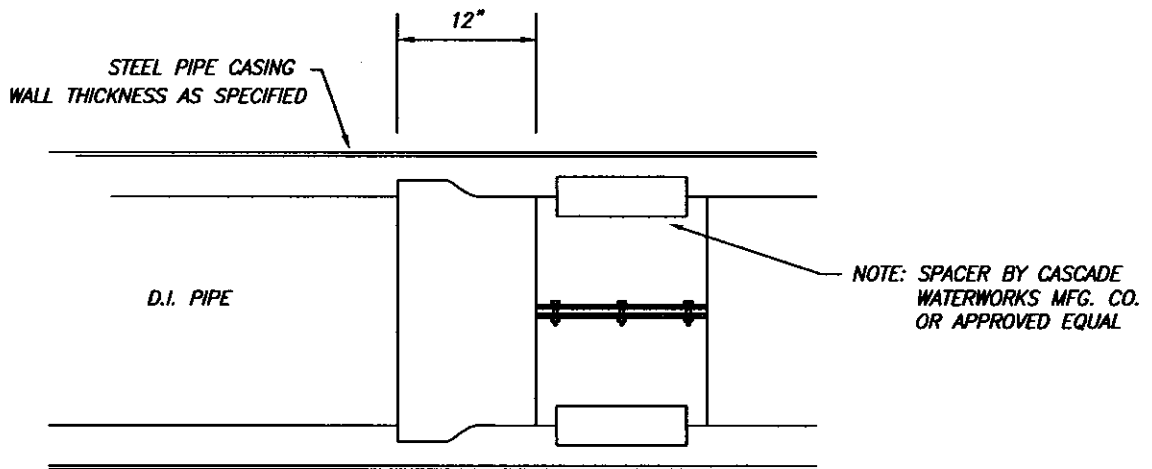
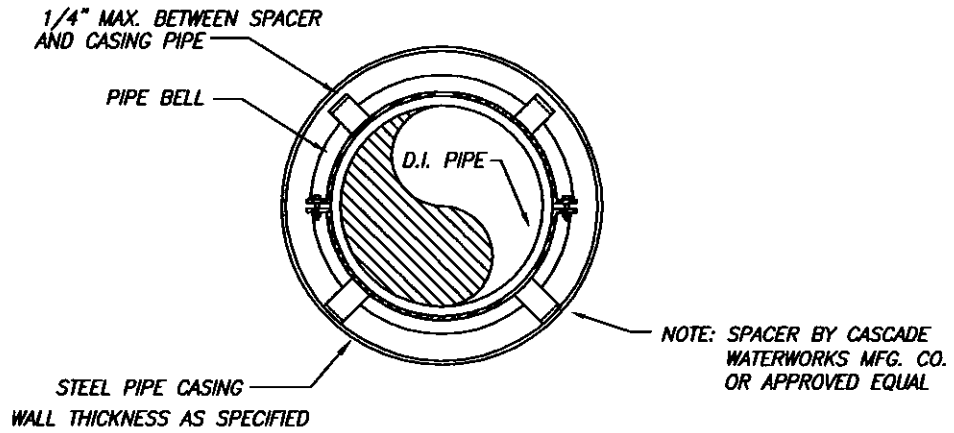

CARRIER PIPE INSTALLATION IN CASING

N.T.S.

CONSTRUCTION DETAIL NO.22

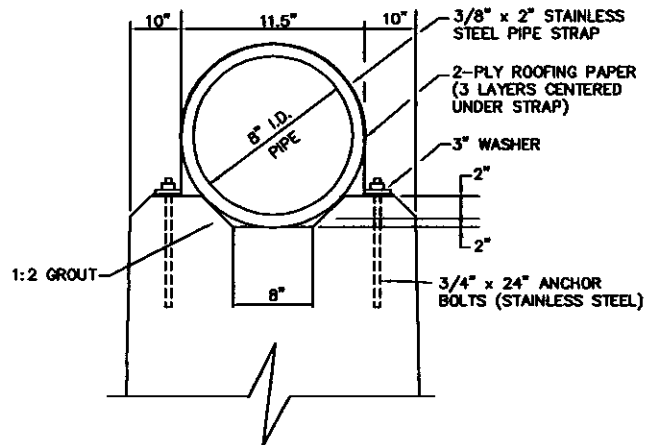

ANCHOR DETAIL
NOT TO SCALE

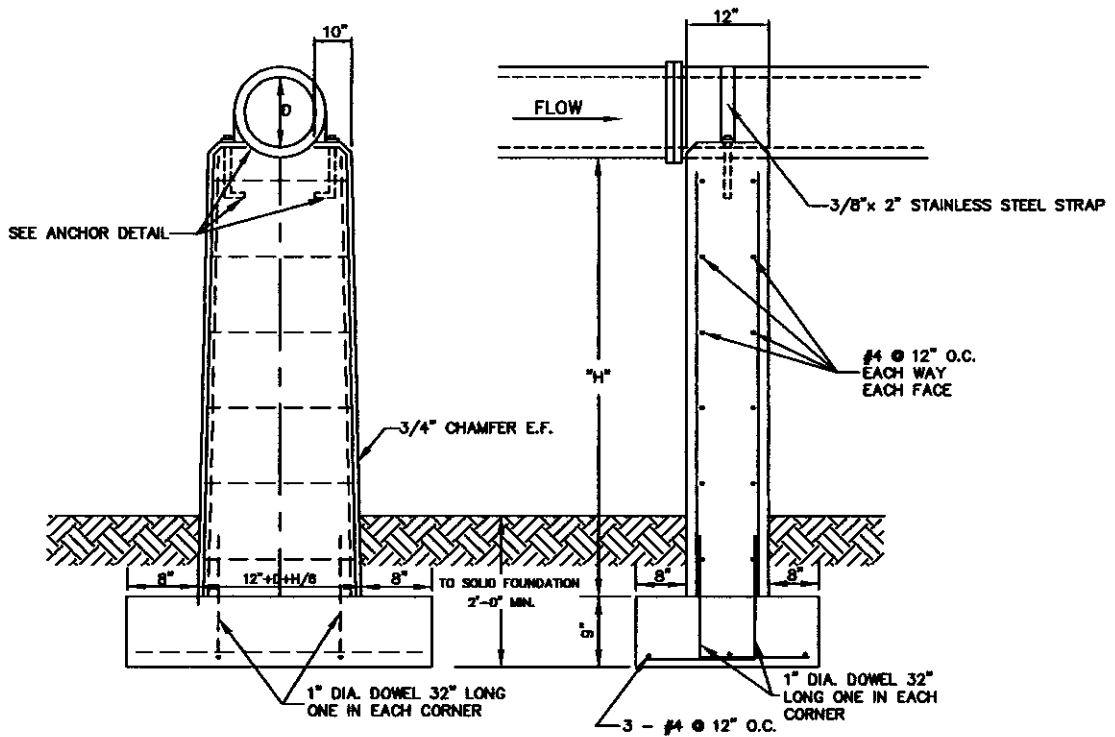

NOTE: ALL HARDWARE TO BE HOT DIPPED GALVANIZED

NOTE: THIS CONSTRUCTION DETAIL IS A SUGGESTED DESIGN ONLY AND DOES NOT RELIEVE THE DESIGN ENGINEER FROM THE RESPONSIBILITY AND OBLIGATION TO CONSIDER ALL ISSUES RELATED TO THE PROPER DESIGN OF ALL STRUCTURES AND SYSTEMS AND COMPLIANCE WITH ALL APPLICABLE REGULATIONS AND STANDARDS. THE DESIGN ENGINEER SHALL SUBMIT ALL PIER SUPPORTED PIPING SYSTEMS TO THE ENGINEERING DEPARTMENT FOR APPROVAL.

PIPE SUPPORTED ON CONCRETE PIERS

NOT TO SCALE

CONSTRUCTION DETAIL NO. 23

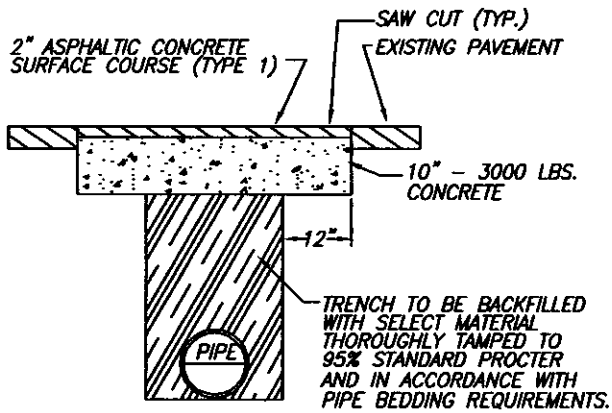

HIGH VOLUME

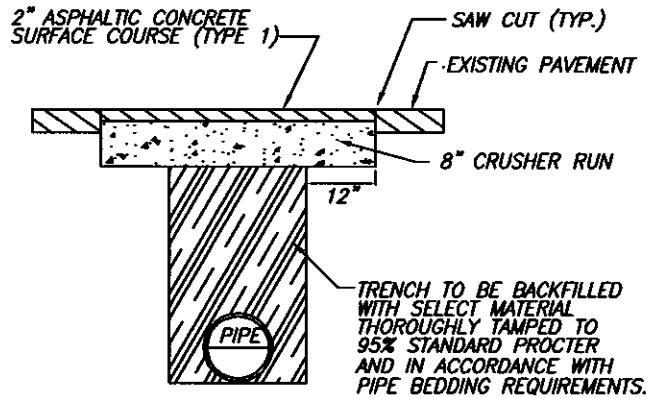

LOW VOLUME

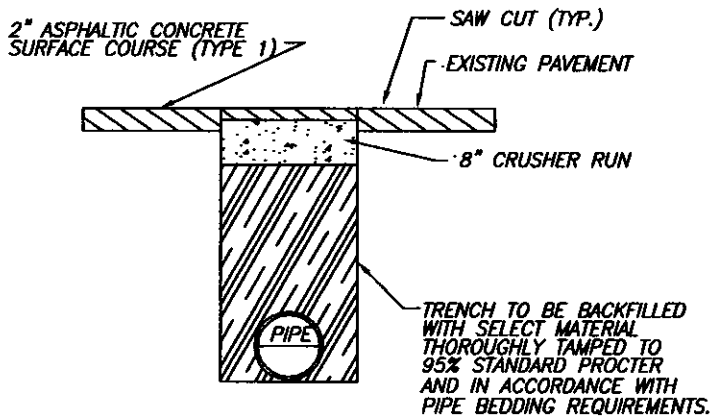

DRIVEWAYS

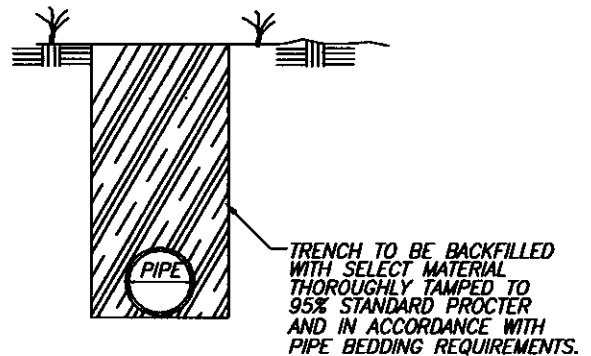

TYPICAL TRENCH

TYPICAL PAVEMENT REPAIR DETAILS

N.T.S.

CONSTRUCTION DETAIL NO. 24

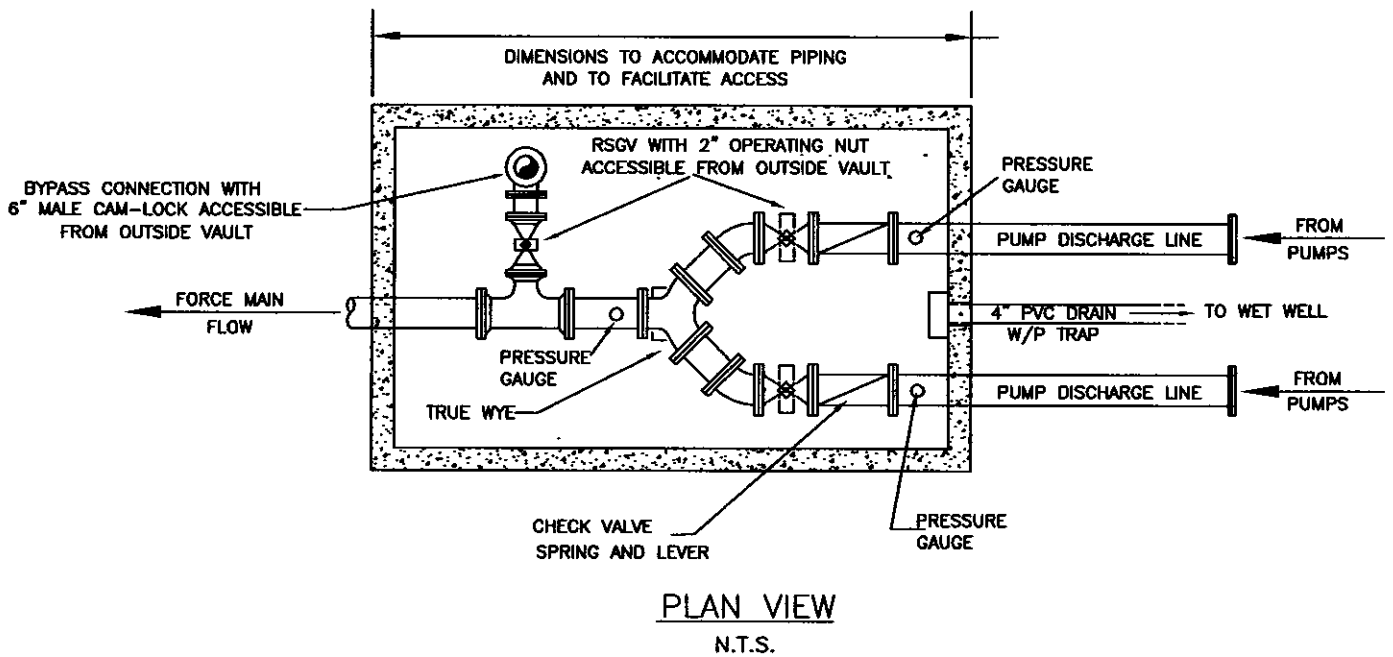
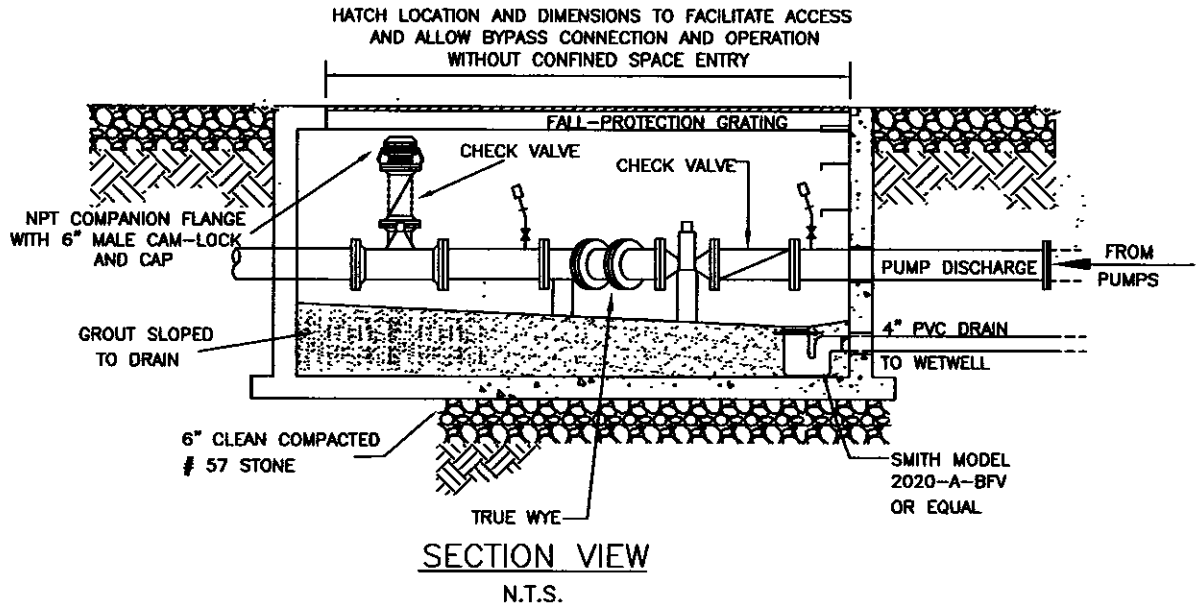

SUBMERSIBLE PUMP STATION VALVE VAULT WITH BYPASS CONNECTION (FOR SUCTION-LIFT STATIONS, SEE NOTE BELOW)

NOTE: DEPENDING ON THE PUMP STATION MANUFACTURER, SUCTION LIFT PUMP STATIONS MAY HAVE SOME OR ALL OF THE VALVES AND PIPING LOCATED ABOVE GROUND, AS PART OF THE PUMP PACKAGE WITHIN THE ENCLOSURE. HOWEVER, THE BYPASS CONNECTION AND ASSOCIATED VALVE(S) SHALL BE LOCATED WITHIN A SEPARATE VAULT, THE LAYOUT OF WHICH SHALL BE SIMILAR TO THAT SHOWN ABOVE. THE ENGINEER SHALL SUBMIT THE VALVE VAULT AND/OR BYPASS CONNECTION ARRANGEMENT TO THE ENGINEERING DEPARTMENT FOR APPROVAL.

CONSTRUCTION DETAIL NO. 25

STANDARD FEATURES:

- AUTO-LOCK T-316 STAINLESS STEEL HOLD OPEN ARM WITH RELEASE HANDLE
- T-316 STAINLESS STEEL HINGES AND ATTACHING HARDWARE
- T-316 STAINLESS STEEL SLAM LOCK WITH REMOVABLE KEY
- STAINLESS STEEL COMPRESSION SPRING ASSIST
- BUILT-IN NEOPRENE CUSHION/GASKET
- NON-OZONE DEPLETING BITUMINOUS COATING
- DOUBLE LEAF CONSTRUCTION
- 300 LBS. PER SQ. FT. LOAD RATING (1464 KG. PER SQ. METER LOAD RATING)
- EXTRUDED ALUMINUM FRAME
- RECESSED LIFTING HANDLE
- ALUMINUM FALL-PROTECTION GRATING
- LIFETIME GUARANTEE
- AS MANUFACTURED BY HALLIDAY, BILCO, US FOUNDRY, OR APPROVED EQUAL.

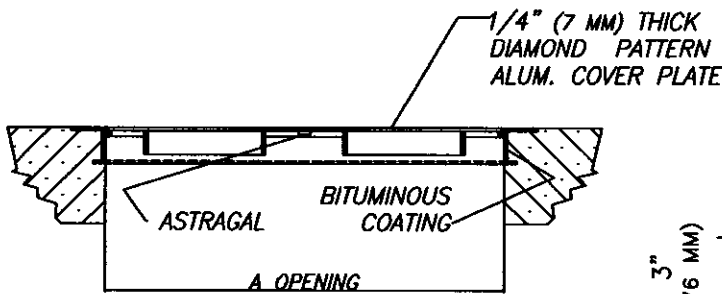
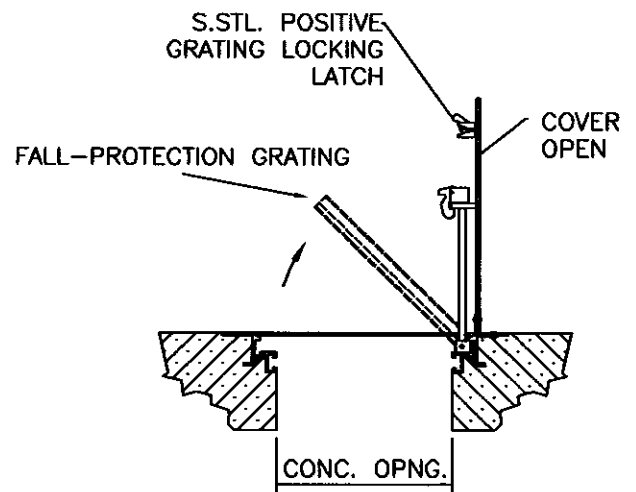
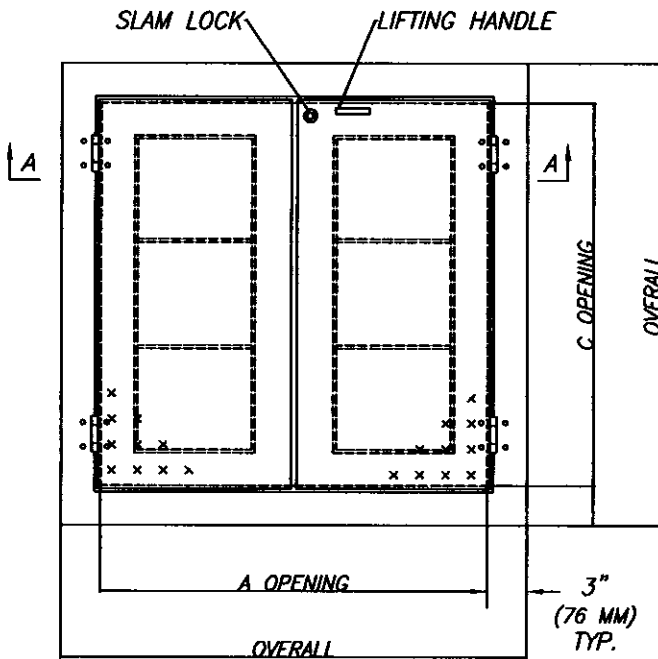
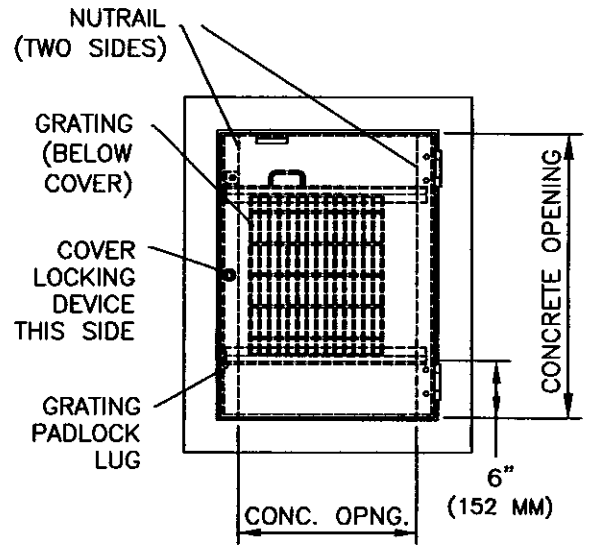

SECTION A-A

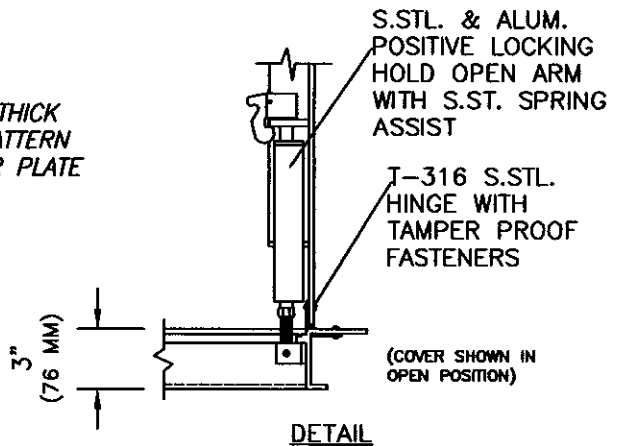

DETAIL

HATCH WITH FALL-PROTECTION GRATING

CONSTRUCTION DETAIL NO. 26

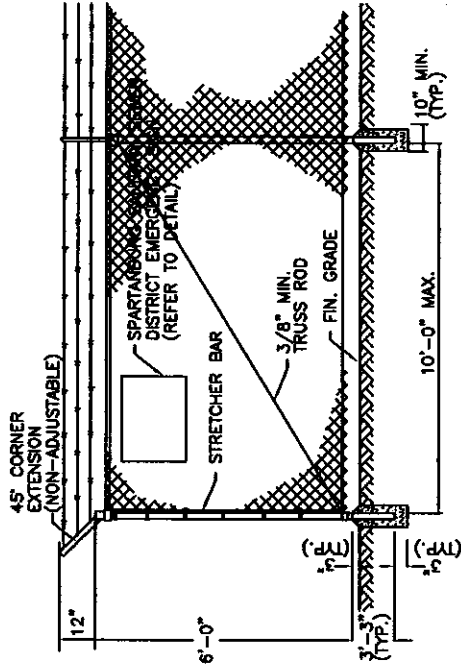

TYPICAL FENCE CORNER DETAIL
 N.T.S.

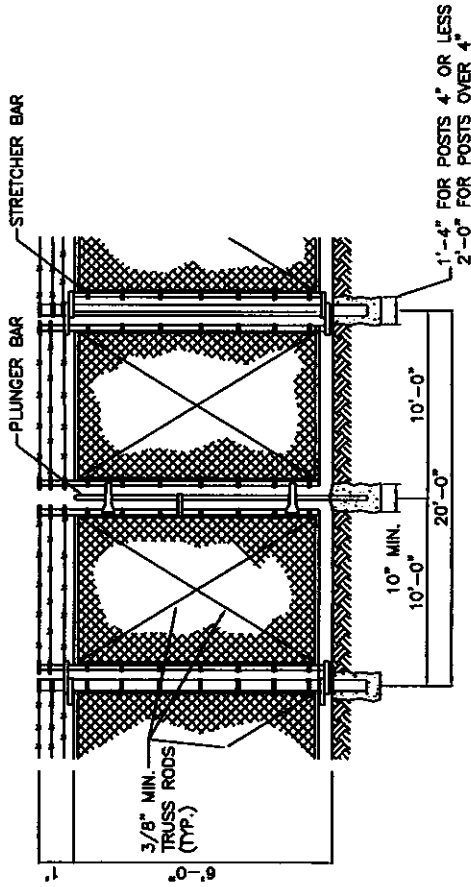

DOUBLE SWING DRIVE GATE DETAIL
 N.T.S.

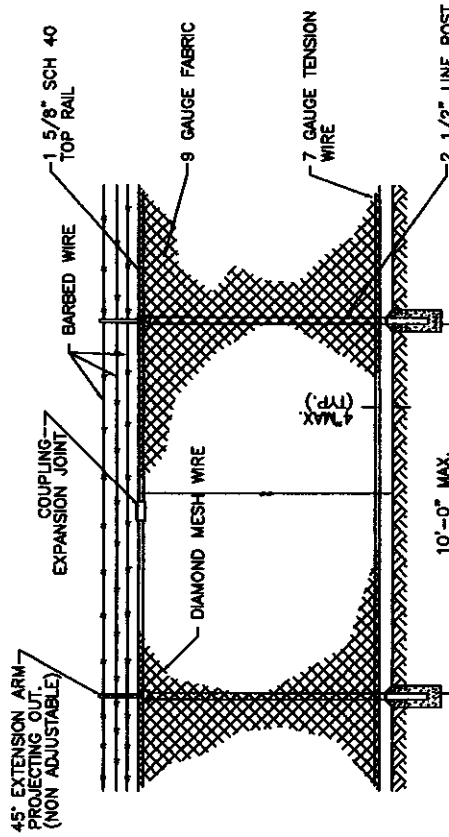

FENCE LINE SPAN DETAIL
 N.T.S.

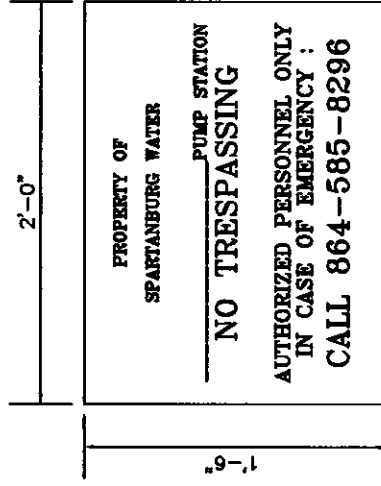

NOTES:

1. ALL LETTERS TO BE WEATHER RESISTANT BLACK PAINT ON WHITE BACKGROUND.
2. MATERIAL FOR PLATE TO BE ALUMINUM.
3. PLATE TO BE MOUNTED USING S.S. HARDWARE.
4. PROVIDE ONE (1) SIGN PER PUMP STATION DEPICTING CORRECT PUMP STATION NAME WHICH SHALL BE SPECIFIED BY THE SPARTANBURG SANITARY SEWER DISTRICT.

EMERGENCY SIGN DETAIL
 N.T.S.

CONSTRUCTION DETAIL NO. 24 TYPICAL PUMP STATION FENCING

N.T.S.

CONSTRUCTION DETAIL NO. 27

CONTROL CANOPY COVER SHALL BE BY GREER AWNING AND SIDING, 864-877-7722, OR APPROVED EQUAL. THE CANOPY SHALL HAVE A PITCHED ROOF WITH 6' x 14' OUTSIDE DIMENSIONS AND 8' CLEAR HEIGHT AND BE CONSTRUCTED OF THE FOLLOWING MATERIALS:

- 1) 4" x 4" SUPPORT POSTS (11 GAUGE STEEL TUBING WITH WELDED STEEL PLATES ANCHORED TO CONCRETE PADS WITH 3/4" x 5" STUD ANCHORS);
- 2) SUPPORT BEAMS (14 GAUGE STEEL TUBING WITH WELDED UPRIGHTS); 2" x 2"
- 3) 1-1/8" WIDE x 3-1/2" HIGH BOS RAFTERS (0.040 GAUGE ALUMINUM SHEET SPACED A MAXIMUM OF 2' ON CENTER);
- 4) AND 20 GAUGE STEP DOWN ALUMINUM SHEET ROOFING WITH 2" CORRUGATIONS & FASTENED TO RAFTERS WITH STAINLESS STEEL SCREWS. ALL STEEL MATERIALS SHALL BE PRIMED AND PAINTED WITH INDUSTRIAL GRADE ENAMEL PAINT.
- 5) ALL ALUMINUM MATERIALS SHALL HAVE INDUSTRIAL GRADE BAKED ENAMEL PAINT. CONTRACTOR SHALL SUBMIT COLOR CHARTS FOR OWNER SELECTION. CANOPY STRUCTURE SHALL BE DESIGNED FOR A MINIMUM 70 MPH WIND LOAD AND 25 LBS/SF INCLUDE (2) 4' FLUORESCENT LIGHTS UNDER THE SHED CANOPY OPERATED BY A WEATHER-PROOF TOGGLE SWITCH.

AWNING WITH FLORESCENT LIGHTS

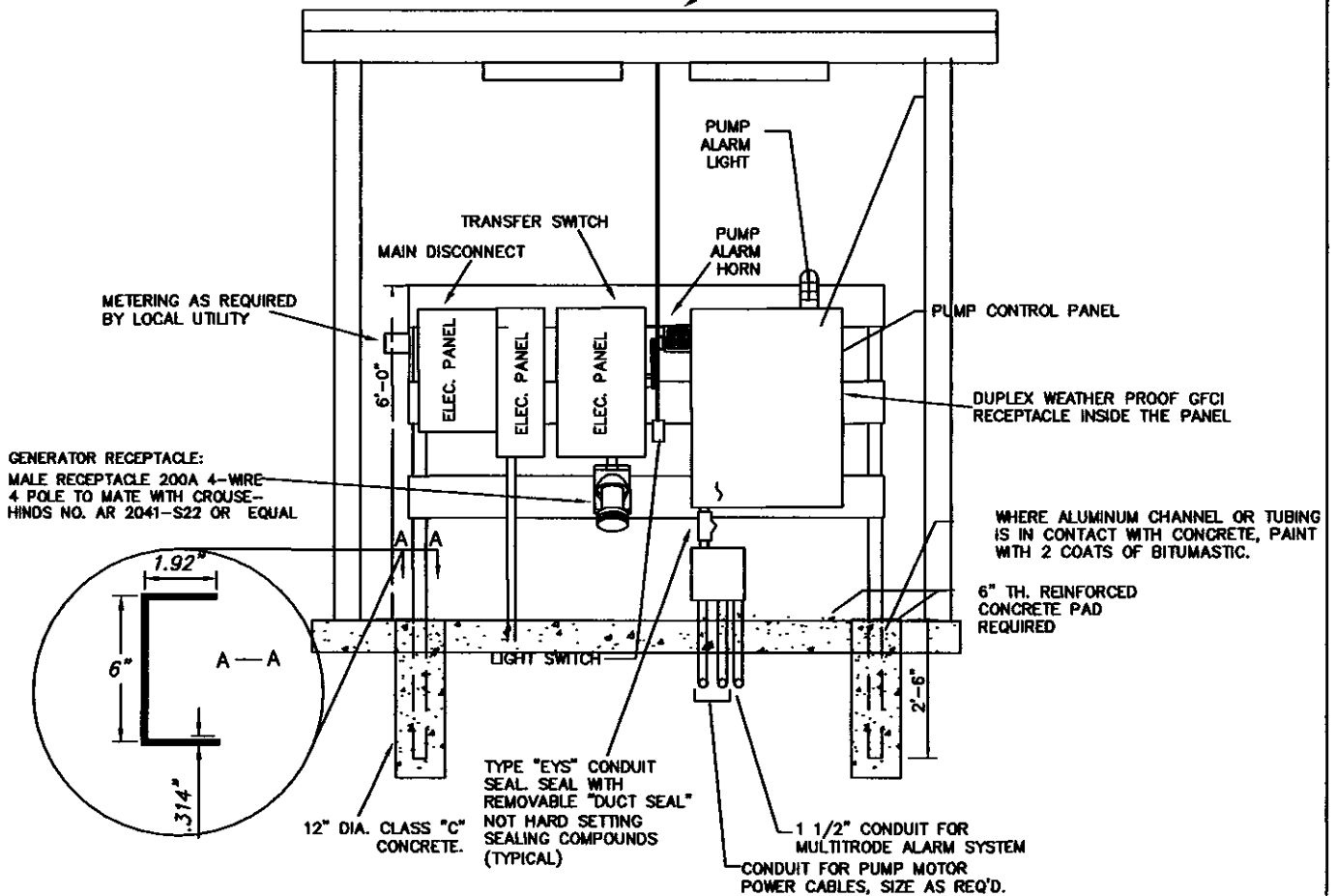

METERING AS REQUIRED BY LOCAL UTILITY

GENERATOR RECEPTACLE:
MALE RECEPTACLE 200A 4-WIRE
4 POLE TO MATE WITH CROUSE-
HINDS NO. AR 2041-S22 OR EQUAL

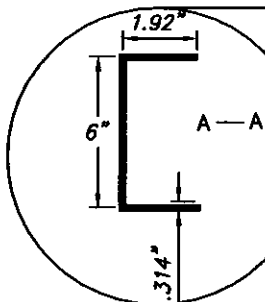

CONTROL PANEL RACK TO BE FABRICATED FROM 6" STANDARD ALUMINUM CHANNEL (SEE CROSS-SECTION DIMENSION) WITH CROSSMEMBERS NOTCHED AND BOLTED TO UPRIGHTS WITH 316 STAINLESS STEEL FASTENERS. NUMBER AND SPACING OF CROSSMEMBERS SHALL BE AS NEEDED TO PROVIDE MOUNTING FOR ALL NECESSARY PANELS, DISCONNECTS AND OTHER HARDWARE. ENGINEER SHALL CONFIRM THAT RACK DESIGN, MOUNTING, AND CONCRETE FOUNDATION IS ADEQUATE FOR EXPECTED WIND LOADING AND WEIGHT OF COMPONENTS. AT ENGINEER'S DISCRETION, RACK MAY BE TO SUPPORTED ON SLAB WITH PROPERLY GUSSETED PADS WELDED TO THE BOTTOM OF THE UPRIGHTS AND ANCHORED TO SLAB WITH HILTI ADHESIVE ANCHORS..

DUPLEX PUMP STATION ELECTRICAL PANEL, RACK, AND AWNING DETAIL

N.T.S.

CONSTRUCTION DETAIL NO. 28

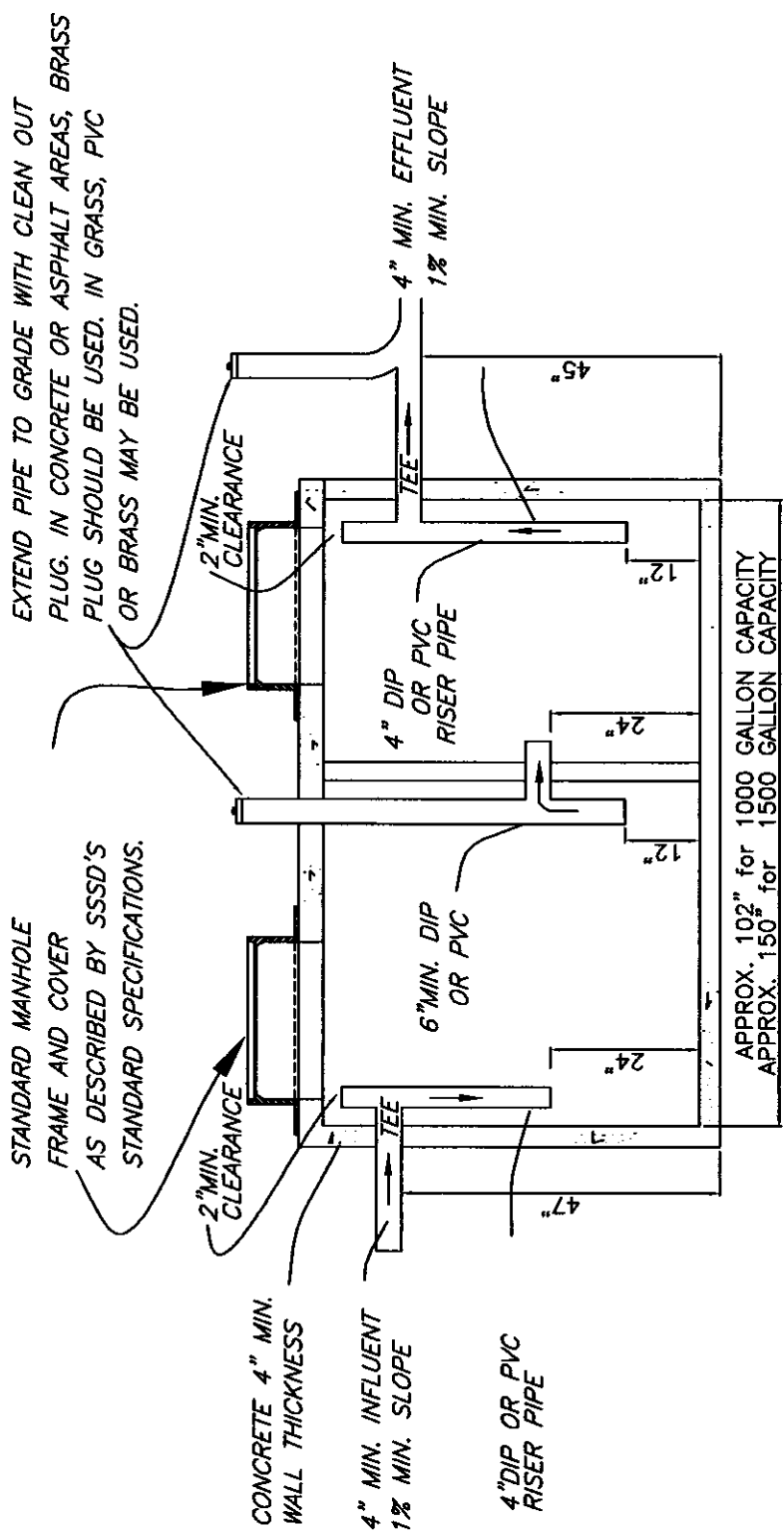

SECTION

1. THE INVERT OF THE INLET PIPE SHALL NOT BE LESS THAN 2" ABOVE THE INVERT OF THE OUTLET PIPE.
2. BAFFLE WALL SHALL BE LOCATED 2/3 THE DISTANCE FROM THE INLET SIDE AND 1/3 THE DISTANCE FROM THE OUTLET SIDE.
3. THE DEPTH LENGTH DIMENSIONS SHOWN ARE FOR STANDARD 1000 GAL. OR 1500 GAL. PRE CAST TANK . THE EXACT SIZE AND TYPE OF EACH INTERCEPTOR SHALL BE APPROVED BY THE SSSD.
4. ALL PIPING SHALL BE DUCTILE IRON, OR SDR*35 OR SCHEDULE 40 PVC.
5. USE BUTYL RUBBER TO SEAL BETWEEN SECTIONS AND TOP AND USE NON-SHRINK GROUT AT ALL PENETRATIONS.
6. LOCATE RISER UNDER MANHOLE COVER TO ENABLE VISUAL INSPECTION OF RISER PIPE.
7. CLEANING SHALL BE PERFORMED AS NECESSARY TO ASSURE PROPER FUNCTIONING OF THE GREASE TRAP. WASTE MATERIAL REMOVED FROM GREASE TRAP SHALL BE DISPOSED OF PROPERLY; I.E.: NOT INTO SANITARY SEWER.
8. TWO-CHAMBER GREASE TRAP IS SHOWN; SINGLE CHAMBER UNIT IS SIMILAR AND MAY ALSO BE AN APPROVED OPTION.

TWO-CHAMBER GREASE TRAP (INTERCEPTOR)

M.S.A.